

PATTERNBOOK TRAILHORSE ONLINE 2025

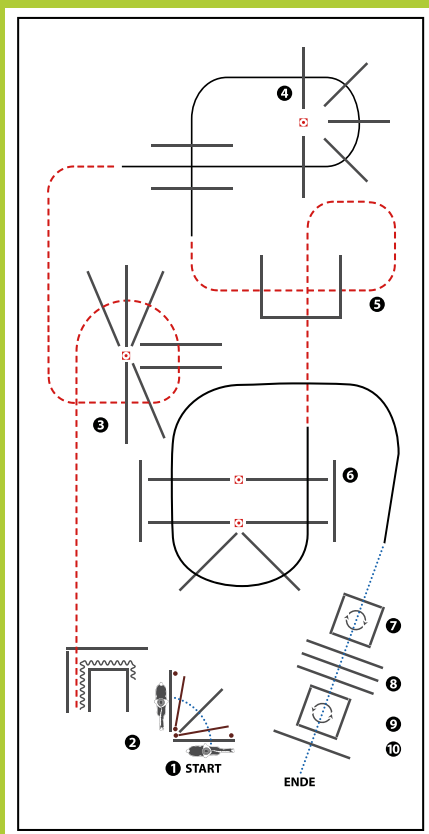

ewu[®]
Erste Westernreiter Union
Deutschland e.V.

ERSTE
WESTERNREITER
UNION
PFERDESPORTVERBANDWESTERNREITEN

EWU Deutschland e.V. | Bundesgeschäftsstelle
Am Thie 6 | 49186 Bad Iburg
Telefon: 0 54 03 / 31 48 39 0 | Fax: 0 54 03 / 31 48 39 9
E-Mail: info@ewu-bund.de | Internet: www.westernreiter.com

Patternbook – TRAILHORSE– Stand: März 2025



Erste Westernreiter Union
Deutschland e.V.

Set 1 (25 x 50 m)	Seite 3		
#1 Q M LK 1/2 Senior	Seite 4		
#2 Q M LK 1/2 Junior	Seite 5		
#3 LK 1/2 Senior	Seite 6		
#4 LK 1/2 Junior	Seite 7		
#5 LK 3	Seite 8		
#6 LK 4/5	Seite 9		
#7 WT und FZ	Seite 10		
#8 THiH	Seite 11		
Set 2 (25 x 50 m)	Seite 12		
#1 Q M LK 1/2 Senior	Seite 13		
#2 Q M LK 1/2 Junior	Seite 14		
#3 LK 1/2 Senior	Seite 15		
#4 LK 1/2 Junior	Seite 16		
#5 LK 3	Seite 17		
#6 LK 4/5	Seite 18		
#7 WT und FZ	Seite 19		
#8 THiH	Seite 20		
Set 3 (20 x 40 m)	Seite 21		
#1 Q M LK 1/2 Senior	Seite 22		
#2 Q M LK 1/2 Junior	Seite 23		
#3 LK 1/2 Senior	Seite 24		
#4 LK 1/2 Junior	Seite 25		
#5 LK 3	Seite 26		
#6 LK 4/5	Seite 27		
#7 WT und FZ	Seite 28		
#8 THiH	Seite 29		
Set 4 mit Brücke (25 x 50 m)	Seite 30		
#1 Q M LK 1/2 Senior	Seite 31		
#2 Q M LK 1/2 Junior	Seite 32		
#3 LK 1/2 Senior	Seite 33		
#4 LK 1/2 Junior	Seite 34		
#5 LK 1/2 Junior	Seite 35		
#6 LK 1/2 Junior	Seite 36		
#7 LK 1/2 Junior	Seite 37		
#8 LK 3	Seite 38		
#9 LK 3	Seite 39		
#10 LK 3	Seite 40		
#11 LK 4/5	Seite 41		
#12 LK 4/5	Seite 42		
#13 WT und FZ	Seite 43		
#14 THiH	Seite 44		
Set 5 (25 x 50 m)	Seite 45		
#1 Q M LK 1/2 Senior	Seite 46		
#2 Q M LK 1/2 Junior	Seite 47		
#3 LK 1/2 Senior	Seite 48		
#4 LK 1/2 Junior	Seite 49		
#5 LK 1/2 Junior	Seite 50		
#6 LK 3	Seite 51		
#7 LK 3	Seite 52		
#8 LK 4/5	Seite 53		
#9 LK 4/5	Seite 54		
#10 WT und FZ	Seite 55		
#11 THiH	Seite 56		
Set 6 mit Brücke (25 x 50 m)	Seite 57		
#1 Q M LK 1/2 Senior	Seite 58		
#2 Q M LK 1/2 Junior	Seite 59		
#3 LK 1/2 Senior	Seite 60		
#4 LK 1/2 Junior	Seite 61		
#5 LK 3	Seite 62		
#6 LK 4/5	Seite 63		
#7 WT und FZ	Seite 64		
#8 THiH	Seite 65		
Set 7 mit Brücke (25 x 50 m)	Seite 66		
#1 Q M LK 1/2 Senior	Seite 67		
#2 Q M LK 1/2 Junior	Seite 68		
#3 LK 1/2 Senior	Seite 69		
#4 LK 1/2 Junior	Seite 70		
#5 LK 3	Seite 71		
#6 LK 4/5	Seite 72		
#7 WT und FZ	Seite 73		
#8 THiH	Seite 74		
Set 8 (25 x 50 m)	Seite 75		
#1 Q M LK 1/2 Senior	Seite 76		
#2 Q M LK 1/2 Junior	Seite 77		
#3 LK 1/2 Senior	Seite 78		
#4 LK 1/2 Junior	Seite 79		
#5 LK 3	Seite 80		
#6 LK 4/5	Seite 81		
#7 WT und FZ	Seite 82		
#8 THiH	Seite 83		
Set 9 mit Brücke (25 x 50 m)	Seite 84		
#1 Q M LK 1/2 Senior	Seite 85		
#2 Q M LK 1/2 Junior	Seite 86		
#3 LK 1/2 Senior	Seite 87		
#4 LK 1/2 Junior	Seite 88		
#5 LK 3	Seite 89		
#6 LK 4/5	Seite 90		
#7 LK 4/5	Seite 91		
#8 WT und FZ	Seite 92		
#9 THiH	Seite 93		
Set 10 (20 x 40 m)	Seite 94		
#1 Q M LK 1/2 Senior	Seite 95		
#2 Q M LK 1/2 Junior	Seite 96		
#3 LK 1/2 Senior	Seite 97		
#4 LK 1/2 Junior	Seite 98		
#5 LK 3	Seite 99		
#6 LK 4/5	Seite 100		
#7 WT und FZ	Seite 101		
#8 THiH	Seite 102		
Set 11 mit Brücke (25 x 50 m)	Seite 103		
#1 Q M LK 1/2 Senior	Seite 104		
#2 Q M LK 1/2 Junior	Seite 105		
#3 LK 1/2 Senior	Seite 106		
#4 LK 1/2 Junior	Seite 107		
#5 LK 3	Seite 108		
#6 LK 4/5	Seite 109		
#8 WT und FZ	Seite 110		
#9 THiH	Seite 111		
Set 12 (25 x 50 m)	Seite 112		
AUFBAU PLAN MIT MASSEN	Seite 113		
#1 Q M LK 1/2 Senior	Seite 114		
#2 Q M LK 1/2 Senior	Seite 115		
#3 Q M LK 1/2 Junior	Seite 116		
#4 LK 1/2 Senior	Seite 117		
#5 LK 1/2 Junior	Seite 118		
#6 LK 3	Seite 119		
#7 LK 4/5	Seite 120		
#8 WT und FZ	Seite 121		
#9 THiH	Seite 122		
#10 LK 4/5 H & D	Seite 123		
#11 LK 1-3 H & D	Seite 124		
Set 13 (25 x 50 m)	Seite 125		
#1 Q M LK 1/2 Senior	Seite 126		
#2 Q M LK 1/2 Junior	Seite 127		
#3 LK 1/2 Senior	Seite 128		
#4 LK 1/2 Junior	Seite 129		
#5 LK 1/2 Junior	Seite 130		
#6 LK 1/2 Junior	Seite 131		
#7 LK 3	Seite 132		
#8 LK 4/5	Seite 133		
#9 LK 4/5	Seite 134		
#10 WT und FZ	Seite 135		
#11 THiH	Seite 136		
Set 14 (25 x 50 m)	Seite 137		
#1 Q M LK 1/2 Senior	Seite 138		
#2 Q M LK 1/2 Junior	Seite 139		
#3 LK 1/2 Senior	Seite 140		
#4 LK 1/2 Junior	Seite 141		
#5 LK 3	Seite 142		
#6 LK 4/5	Seite 143		
#7 WT und FZ	Seite 144		
#8 THiH	Seite 145		
Set 15 (25 x 50 m)	Seite 146		
#1 Q M LK 1/2 Senior	Seite 147		
#2 Q M LK 1/2 Junior	Seite 148		
#3 LK 1/2 Senior	Seite 149		
#4 LK 1/2 Junior	Seite 150		
#5 LK 3	Seite 151		
#6 LK 4/5	Seite 152		
#7 LK 4/5	Seite 153		
#8 WT und FZ	Seite 154		
#9 THiH	Seite 155		

Trail Set 1

Pattern 1-8

Arenagröße mind. 25 x 50 m

Für TH-Pattern gelten folgende Abstände und Maße:

WALK / WALK OVER	Abstand 40 - 60 cm • Erhöhung max. 30 cm. Bei Erhöhung sollte der Mindestabstand 55 cm betragen.
JOG / JOG OVER	Abstand 90 - 105 cm • Erhöhung max. 20 cm.
EXTENDED JOG	Abstand 105 - 125 cm.
LOPE / LOPE OVER	Abstand 180 - 210 cm • Erhöhung max. 20 cm.
EXTENDED LOPE	Abstand 210 - 225 cm.
BACK UP	Abstandmind. 100 cm, Erhöhung max. 30 cm.
SIDEPASS	Abstand in einer Gasse mind. 200 cm (ganzes Pferd), mind. 60 cm (1 Beinpaar zwischen zwei Stangen), Erhöhung max. 30 cm.
SERPENTIN WALK	Abstand mind. 200 cm
SERPENTIN JOG	Abstand mind. 250 cm
GATE	Breite mind. 90 cm, Länge 250 cm,
BRIDGE	Breite mind. 150 cm, Länge 250 cm,
BRIDGE WITH RAILING	Breite mind. 150 cm, Länge 250 cm,
BOX	Abstand 180 - 210 cm
JUMP	Erhöhung max. 45 cm

Zwischen den Hindernissen sollte eine:

Trabstrecke von mind. 10,00 m

Galoppstrecke von mind. 20,00 m

Volten sollten für Reiter der LK 5 und 4 nicht weniger als 12,00 m Durchmesser,
für LK 1 bis 3 nicht weniger als 10,00 m betragen

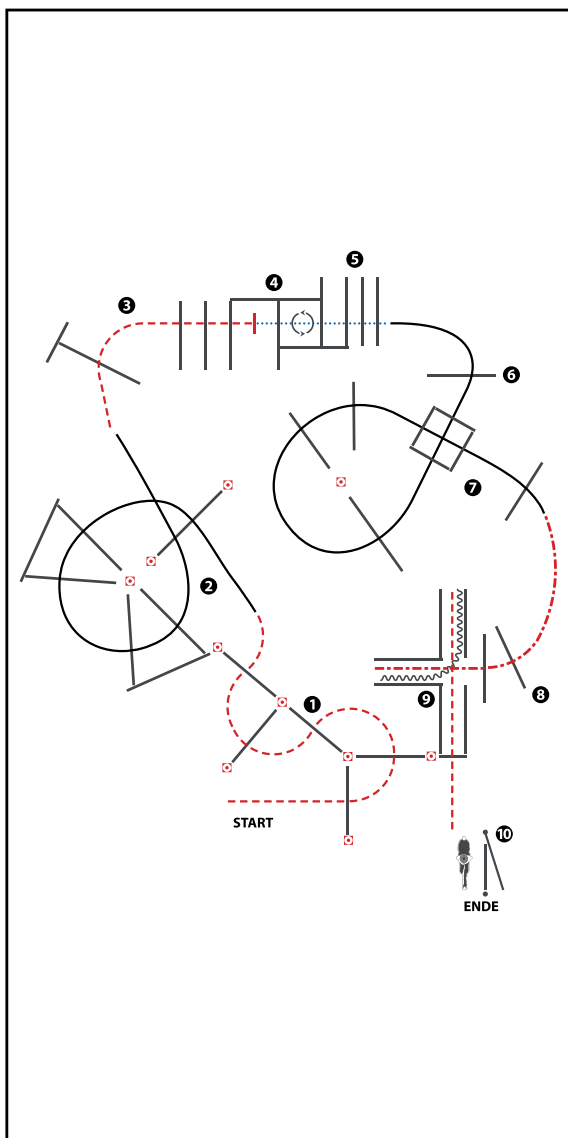

(Erhöhungen optional)

- 1) JOG THRU SERPENTINE, JOG OVER POLES
- 2) LOPE OVER (LL)
- 3) JOG OVER, JOG AND STOP BETWEEN POLE AND BOX
- 4) WALK INTO BOX, 360° TURN EITHER WAY (LEFT OR RIGHT), WALK OUT
- 5) WALK OVER
- 6) LOPE OVER (RL) (4 POLES)
- 7) LOPE OVER (RL) (5 POLES)
- 8) EXTENDET JOG OVER, EXTENDET JOG INTO CHUTE
- 9) BACK UP, JOG OUT, JOG OVER
- 10) GATE (LH) OPEN, WALK OVER POLE, CLOSE GATE

WALK (SCHRITT)
EXTENDED WALK
JOG/TROT (TRAB)
EXTENDED TROT
LOPE (GALOPP)
EXTENDED LOPE
BACK UP (RÜCKWÄRTS)	~~~~~
LEAD CHANGE (GALOPPWECHSEL)	=====
TURN (DREHUNG)	⤵
ERSTE	=====
WESTENREITER	=====
UNION	=====
WESTENREITER	=====

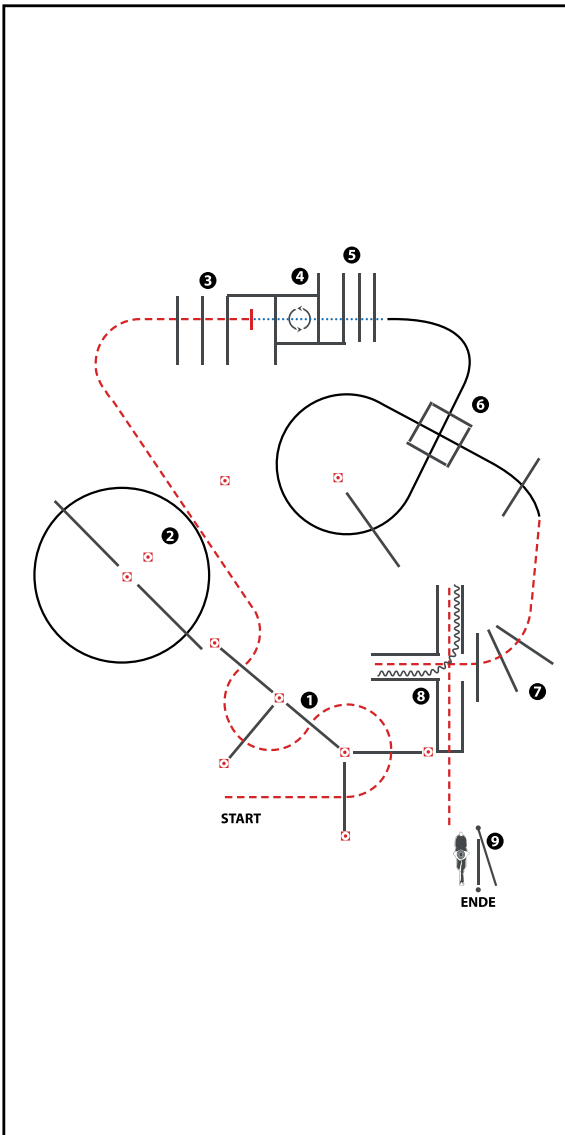

(Erhöhungen optional)

- 1) JOG THRU SERPENTINE, JOG OVER POLES
- 2) LOPE OVER (LL),
- 3) JOG OVER AND STOP BETWEEN POLE AND BOX
- 4) WALK INTO BOX, 360° TURN EITHER WAY (LEFT OR RIGHT), WALK OUT
- 5) WALK OVER
- 6) LOPE OVER (RL)
- 7) JOG OVER, JOG INTO CHUTE
- 8) BACK UP, JOG OUT, JOG OVER
- 9) GATE (LH) OPEN, WALK OVER POLE, CLOSE GATE

WALK (SCHRITT)
EXTENDED WALK
JOG/TROT (TRAB)	-----
EXTENDED TROT	-----
LOPE (GALOPP)	=====
EXTENDED LOPE	=====
BACK UP (RÜCKWÄRTS)	~~~~~
LEAD CHANGE (GALOPPWECHSEL)	=====
TURN (DREHUNG)	⤵
	ERSTE WESTENREITER UNION WIRTSCHAFTSUNIVERSITÄT SIEGEN

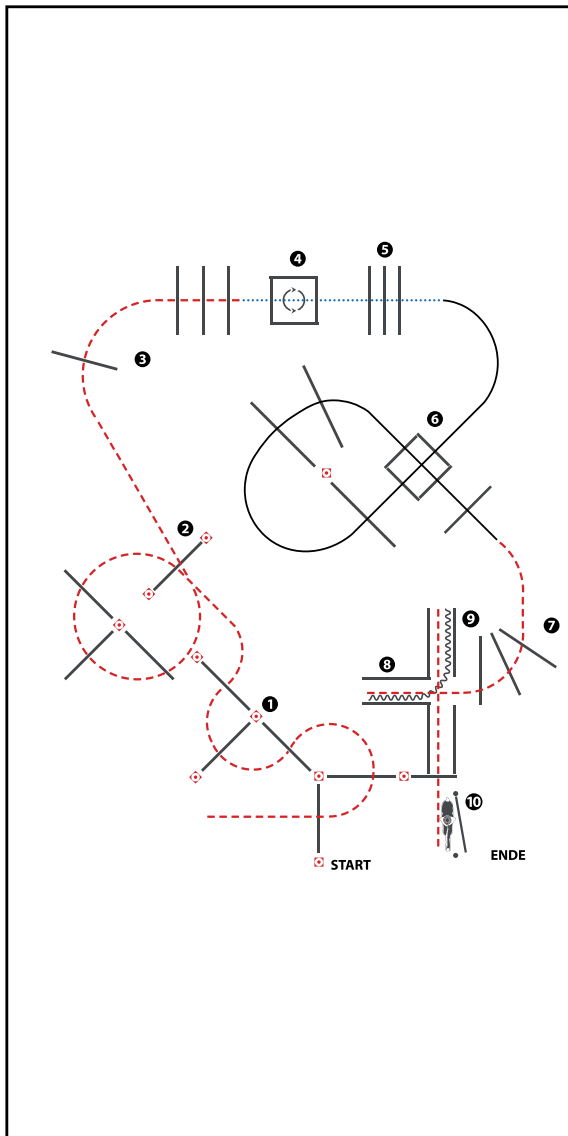

(Erhöhungen optional)

- 1) JOG THRU SERPENTINE, JOG OVER POLES
- 2) JOG OVER POLES (5 POLES)
- 3) JOG OVER POLES (4 POLES)
- 4) WALK INTO BOX, 360° TURN EITHER WAY (LEFT OR RIGHT), WALK OUT
- 5) WALK OVER
- 6) LOPE OVER (RL)
- 7) JOG OVER, JOG INTO CHUTE
- 8) BACK UP
- 9) JOG OUT, JOG OVER
- 10) GATE (LH)

WALK (SCHRITT)
EXTENDED WALK
JOG/TROT (TRAB)	-----
EXTENDED TROT	-----
LOPE (GALOPP)	=====
EXTENDED LOPE	=====
BACK UP (RÜCKWÄRTS)	~~~~~
LEAD CHANGE (GALOPPWECHSEL)	=====
TURN (DREHUNG)	⤵
	ERSTE WESTERWEITER UNION WIEDERFÖRDERNDEN VERBÄNDLICHEN

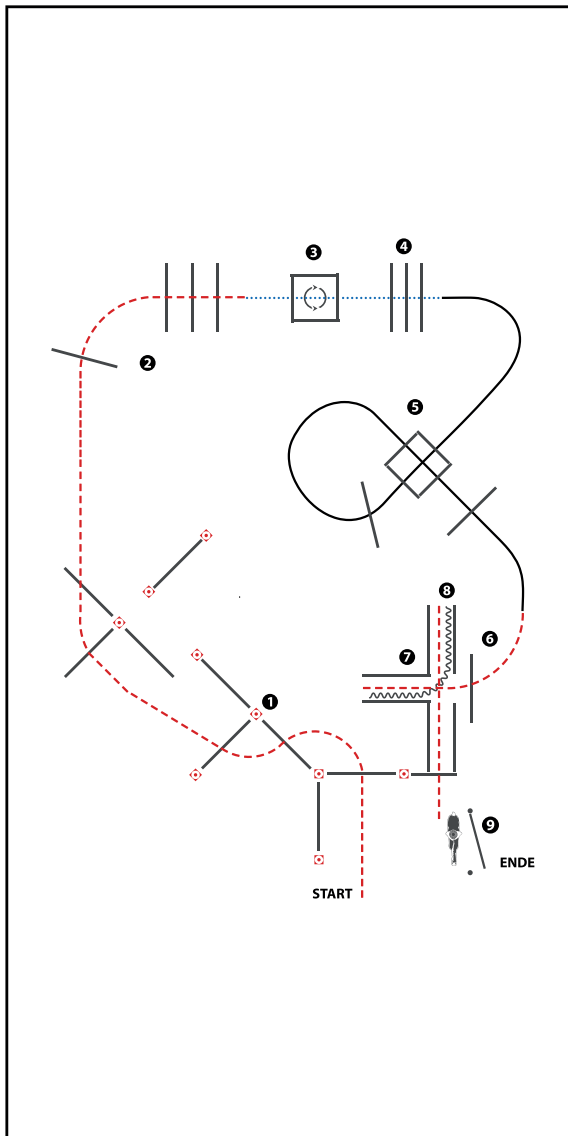

(Erhöhungen optional)

- 1) JOG THRU SERPENTINE, (5 POLES)
- 2) JOG OVER (4 POLES)
- 3) WALK INTO BOX, 360° TURN EITHER WAY (LEFT OR RIGHT),
WALK OUT
- 4) WALK OVER
- 5) LOPE OVER (RL)
- 6) JOG OVER, JOG INTO CHUTE
- 7) BACK UP
- 8) JOG OUT, JOG OVER
- 9) GATE (LH)

WALK (SCHRITT)
EXTENDED WALK
JOE/TROT (TRAB)
EXTENDED TROT
LOPE (GALOPP)
EXTENDED LOPE
BACK UP (RÜCKWÄRTS)
LEAD CHANGE (GALOPPWECHSEL)
TURN (DREHUNG)
	ERSTE WESTERWEITER UNION WIEDERFÖRDERNDEN VEREINEN

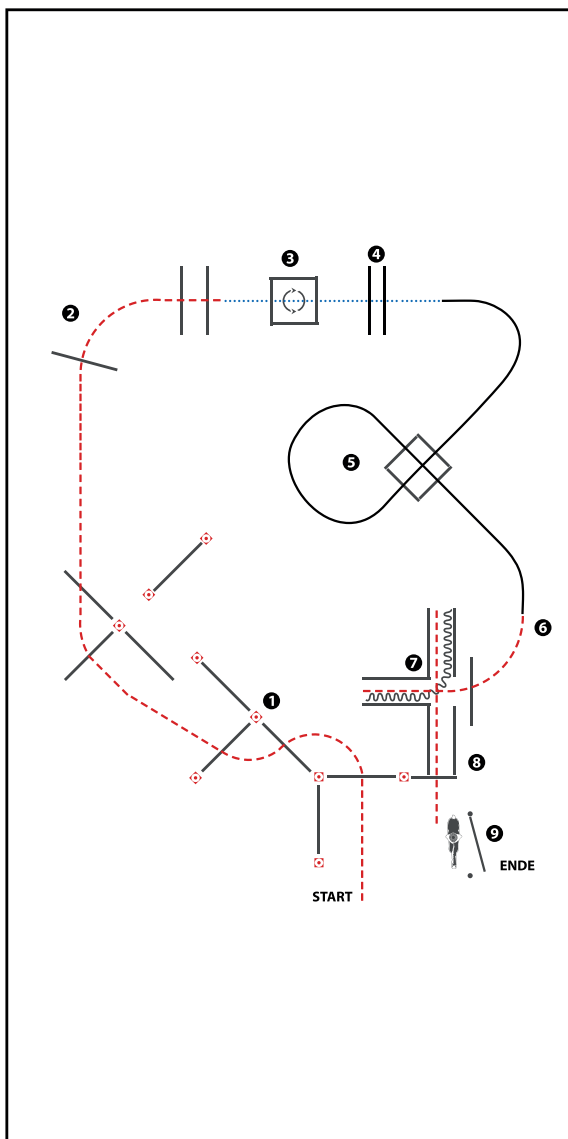

(Erhöhungen optional)

- 1) JOG THRU SERPENTINE, JOG OVER POLES
- 2) JOG OVER POLES (3 POLES)
- 3) WALK INTO BOX, 360° TURN EITHER WAY (LEFT OR RIGHT), WALK OUT
- 4) WALK OVER
- 5) LOPE OVER (RL)
- 6) JOG OVER, JOG INTO CHUTE
- 7) BACK UP
- 8) JOG OUT, JOG OVER
- 9) GATE (LH)

WALK (SCHRITT)
EXTENDED WALK
JOG/TROT (TRAB)	-----
EXTENDED TROT	-----
LOPE (GALOPP)	=====
EXTENDED LOPE	=====
BACK UP (RÜCKWÄRTS)	~~~~~
LEAD CHANGE (GALOPPWECHSEL)	=====
TURN (DREHUNG)	⦿
ERSTE	=====
WESTERWEITER	=====
UNION	=====
WIEDERWECHSEL	=====

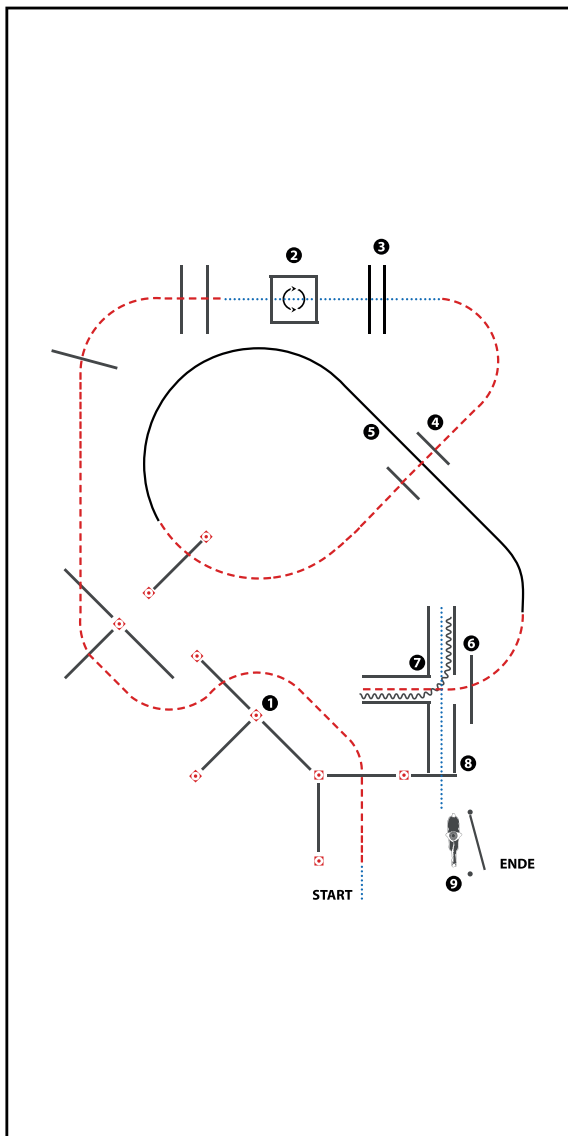

(Erhöhungen optional)

- 1) WALK, JOG THRU SERPENTINE, JOG OVER POLES
- 2) WALK INTO BOX, 360° TURN EITHER WAY (LEFT OR RIGHT), WALK OUT
- 3) WALK OVER
- 4) JOG OVER
- 5) LOPE (RL)
- 6) JOG OVER, JOG INTO CHUTE
- 7) BACK UP
- 8) WALK OUT, WALK OVER
- 9) GATE (LH)

WALK (SCHRITT)	
EXTENDED WALK	
JOG/TROT (TRAB)	
EXTENDED TROT	
LOPE (GALOPP)	
EXTENDED LOPE	
BACK UP (RÜCKWÄRTS)	
LEAD CHANGE (GALOPPWECHSEL)	
TURN (DREHUNG)	
	ERSTE
	WESTENREITER
	UNION
	WESTENREITER
	UNION

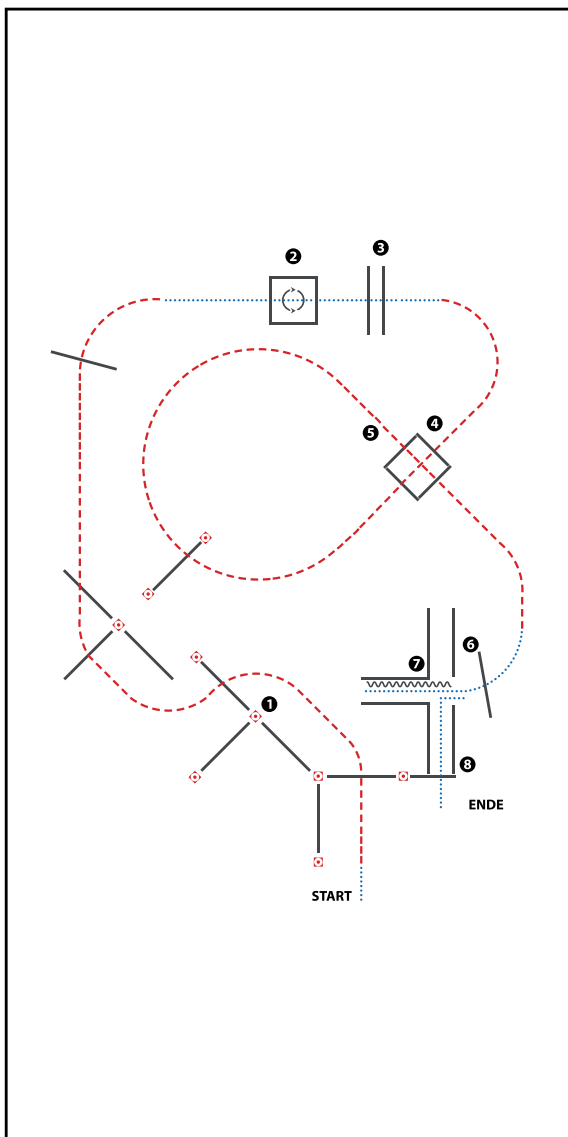

- 1) JOG THRU SEPENTINE, JOG OVER POLES
(Jog Slalom über Stangen)
- 2) WALK INTO BOX, 360° TURN EITHER WAY (LEFT OR RIGHT),
WALK OUT (Schritt in die Box, 360° Turn rechts oder links,
im Schritt aus der Box)
- 3) WALK OVER (Schrittstangen)
- 4) JOG OVER (Trabstangen)
- 5) JOG OVER (Trabstangen)
- 6) WALK OVER INTO CHUTE (Schrittstange, im Schritt in die Gasse)
- 7) BACK UP (Rückwärts)
- 8) WALK OUT (im Schritt aus dem Gasse reiten)

WALK (SCHRITT)	
EXTENDED WALK	
JOG/TROT (TRAB)	
EXTENDED TROT	
LOPE (GALOPP)	
EXTENDED LOPE	
BACK UP (RÜCKWÄRTS)	
LEAD CHANGE (GALOPPWECHSEL)	
TURN (DREHUNG)	
ERSTE	
WESTENREITER	
UNION	
WESTENREITER	

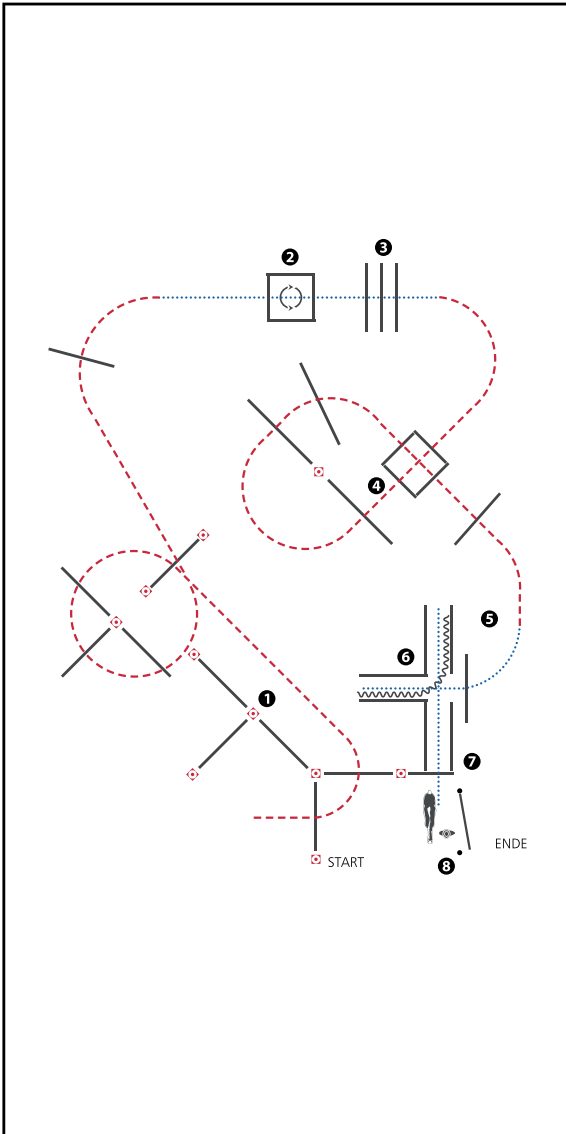

- 1) JOG OVER POLES
- 2) WALK INTO BOX, 360° TURN RIGHT, WALK OUT
- 3) WALK OVER
- 4) JOG OVER
- 5) WALK OVER, WALK INTO CHUTE
- 6) BACK UP
- 7) WALK OUT, WALK OVER
- 8) GATE (LH)

WALK (SCHRITT)
EXTENDED WALK
JOG/TROT (TRAB)
EXTENDED TROT
LOPE (GALOPP)	=====
EXTENDED LOPE	=====
BACK UP (RÜCKWÄRTS)	~~~~~
LEAD CHANGE (GALOPPWECHSEL)	=====
TURN (DREHUNG)	⤵
ERSTE	=====
WESTENREITER	=====
UNION	=====
WELDPFERDEBUND WELDPFERTE	=====

Trail Set 2

Pattern 1-8

Arenagröße mind. 25 x 50 m

Für TH-Pattern gelten folgende Abstände und Maße:

WALK / WALK OVER	Abstand 40 - 60 cm • Erhöhung max. 30 cm. Bei Erhöhung sollte der Mindestabstand 55 cm betragen.
JOG / JOG OVER	Abstand 90 - 105 cm • Erhöhung max. 20 cm.
EXTENDED JOG	Abstand 105 - 125 cm.
LOPE / LOPE OVER	Abstand 180 - 210 cm • Erhöhung max. 20 cm.
EXTENDED LOPE	Abstand 210 - 225 cm.
BACK UP	Abstandmind. 100 cm, Erhöhung max. 30 cm.
SIDEPASS	Abstand in einer Gasse mind. 200 cm (ganzes Pferd), mind. 60 cm (1 Beinpaar zwischen zwei Stangen), Erhöhung max. 30 cm.
SERPENTIN WALK	Abstand mind. 200 cm
SERPENTIN JOG	Abstand mind. 250 cm
GATE	Breite mind. 90 cm, Länge 250 cm,
BRIDGE	Breite mind. 150 cm, Länge 250 cm,
BRIDGE WITH RAILING	Breite mind. 150 cm, Länge 250 cm,
BOX	Abstand 180 - 210 cm
JUMP	Erhöhung max. 45 cm

Zwischen den Hindernissen sollte eine:

Trabstrecke von mind. 10,00 m

Galoppstrecke von mind. 20,00 m

Volten sollten für Reiter der LK 5 und 4 nicht weniger als 12,00 m Durchmesser,
für LK 1 bis 3 nicht weniger als 10,00 m betragen

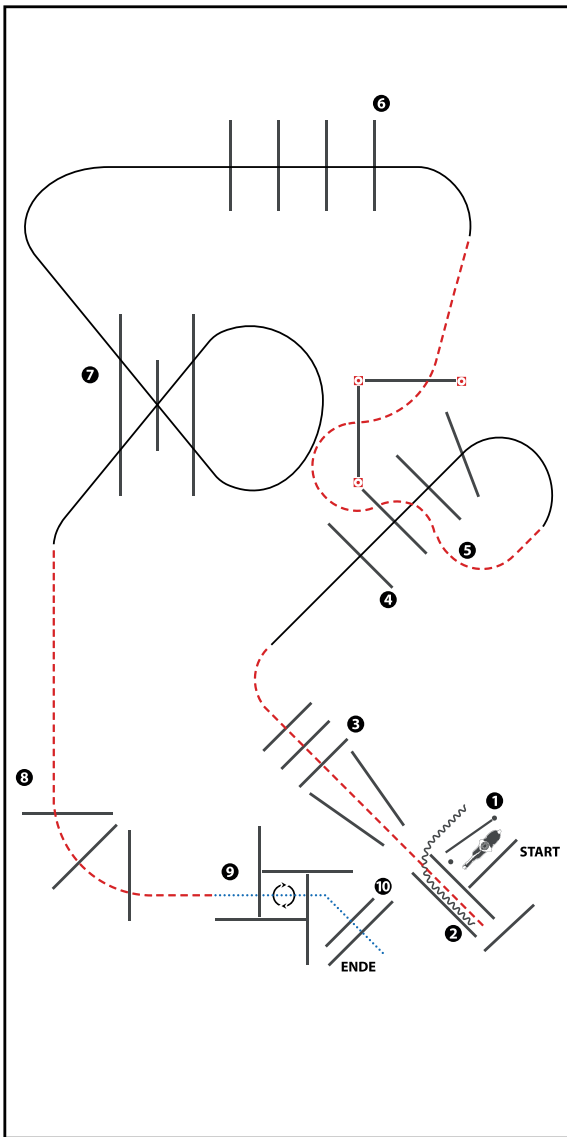

(Erhöhungen optional)

- 1) GATE (RH)
- 2) BACK UP, JOG OUT
- 3) JOG OVER
- 4) LOPE OVER (RL)
- 5) JOG THRU SERPENTINE, JOG OVER POLES
- 6) LOPE OVER (LL)
- 7) LOPE OVER (LL) (Abstand 1,50m)
- 8) JOG OVER
- 9) STOP OR BREAK TO WALK, WALK INTO BOX, 360° TURN EITHER WAY (LEFT OR RIGHT), WALK OUT
- 10) WALK OVER

WALK (SCHRITT)
EXTENDED WALK
JOG/TROT (TRAB)	-----
EXTENDED TROT	-----
LOPE (GALOPP)	=====
EXTENDED LOPE	=====
BACK UP (RÜCKWÄRTS)	~~~~~
LEAD CHANGE (GALOPPWECHSEL)	=====
TURN (DREHUNG)	⤵
	ERSTE WESTERWEITER UNION PRODUKTION

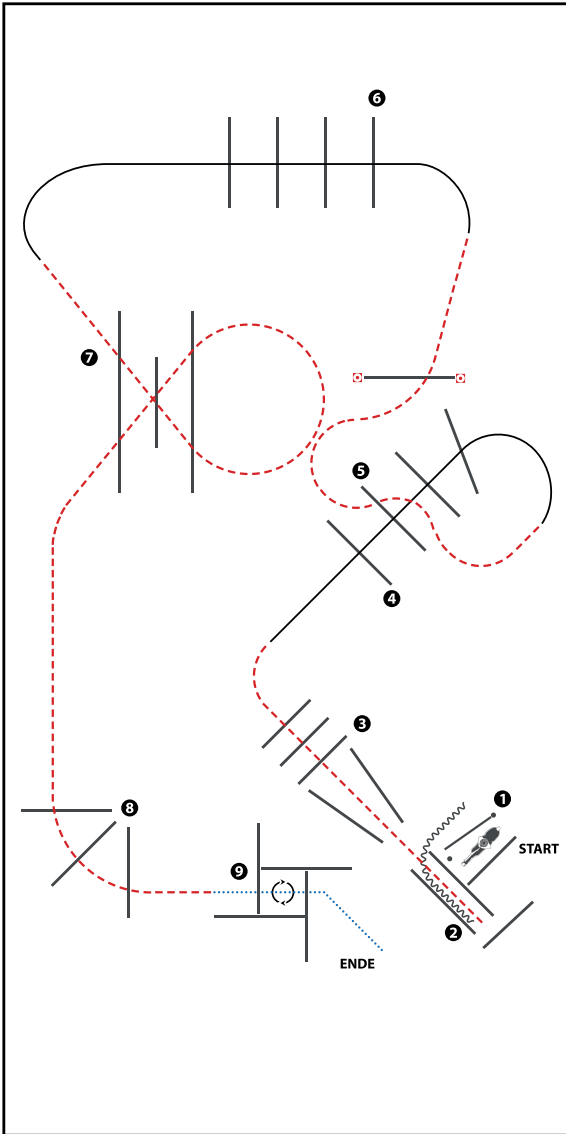

(Erhöhungen optional)

- 1) GATE (RH)
- 2) BACK UP, JOG OUT
- 3) JOG OVER
- 4) LOPE OVER (RL)
- 5) JOG THRU SERPENTINE, JOG OVER POLES
- 6) LOPE OVER (LL)
- 7) JOG OVER (Abstand 1,50m)
- 8) JOG OVER
- 9) WALK INTO BOX, 360° TURN EITHER WAY (LEFT OR RIGHT), WALK OUT

WALK (SCHRITT)
EXTENDED WALK
JOE/TROT (TRAB)
EXTENDED TROT
LOPE (GALOPP)
EXTENDED LOPE
BACK UP (RÜCKWÄRTS)
LEAD CHANGE (GALOPPWECHSEL)
TURN (DREHUNG)
ERSTE
WESTENREITER
UNION
WELDPFERDEBUND WESTERWALD

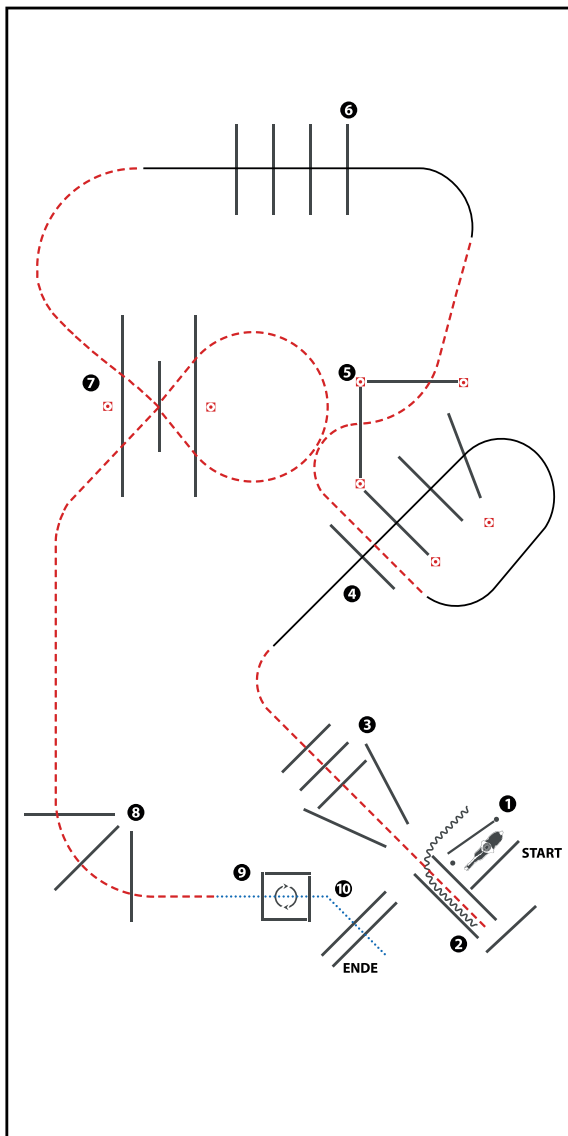

(Erhöhungen optional)

- 1) GATE (RH)
- 2) BACK UP, JOG OUT
- 3) JOG OVER
- 4) LOPE OVER (RL)
- 5) JOG OVER
- 6) LOPE OVER (LL)
- 7) JOG OVER (Abstand 1,50m)
- 8) JOG OVER
- 9) WALK INTO BOX, 360° TURN EITHER WAY (LEFT OR RIGHT), WALK OUT
- 10) WALK OVER

WALK (SCHRITT)
EXTENDED WALK
JOE/TROT (TRAB)	-----
EXTENDED TROT	-----
LOPE (GALOPP)	=====
EXTENDED LOPE	=====
BACK UP (RÜCKWÄRTS)	~~~~~
LEAD CHANGE (GALOPPWECHSEL)	=====
TURN (DREHUNG)	
	ERSTE
	WESTENREITER
	UNION
	WELDPFERDEBUND WESTENREITER

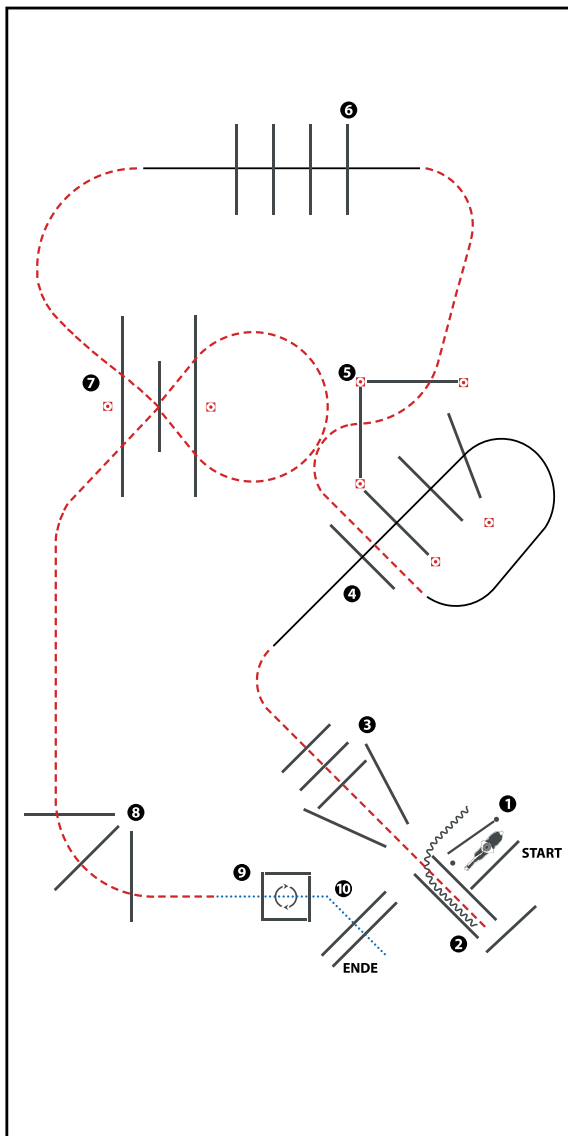

(Erhöhungen optional)

- 1) GATE (RH)
- 2) BACK UP, JOG OUT
- 3) JOG OVER
- 4) LOPE OVER (RL)
- 5) JOG OVER
- 6) LOPE OVER (LL)
- 7) JOG OVER (Abstand 1,50m)
- 8) JOG OVER
- 9) WALK INTO BOX, 360° TURN EITHER WAY (LEFT OR RIGHT), WALK OUT
- 10) WALK OVER

WALK (SCHRITT)
EXTENDED WALK
JOG/TROT (TRAB)
EXTENDED TROT
LOPE (GALOPP)
EXTENDED LOPE
BACK UP (RÜCKWÄRTS)
LEAD CHANGE (GALOPPWECHSEL)
TURN (DREHUNG)
	ERSTE WESTENREITER UNION WIRTSCHAFTSCHAFTSCHAFT

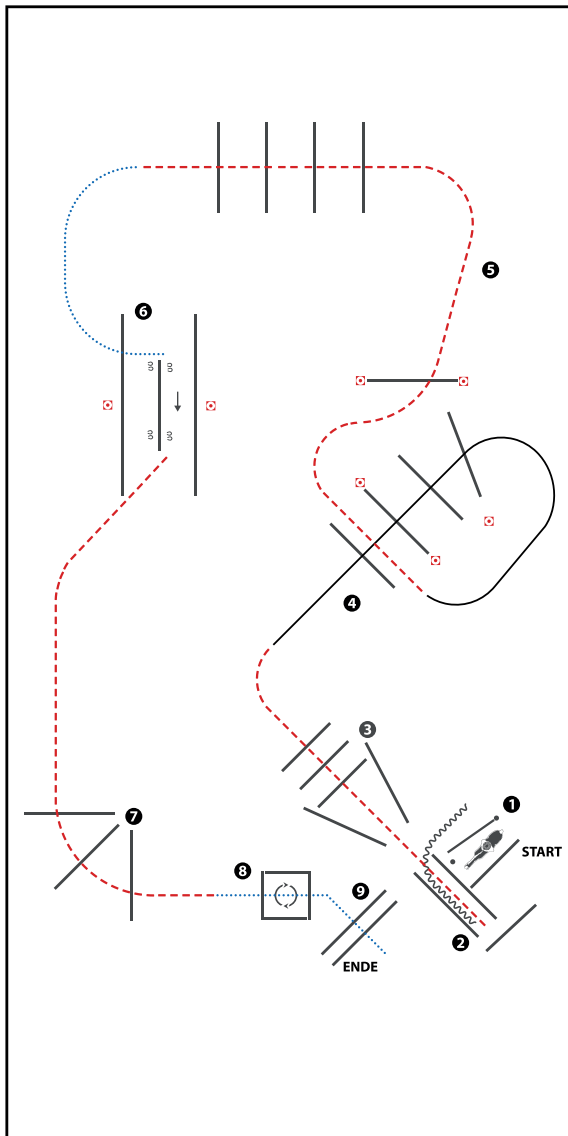

(Erhöhungen optional)

- 1) GATE (RH)
- 2) BACK UP, JOG OUT
- 3) JOG OVER
- 4) LOPE OVER (RL)
- 5) JOG OVER
- 6) WALK INTO CHUTE, SIDEPASS RIGHT
- 7) JOG OVER
- 8) STOP OR BREAK TO WALK, WALK INTO BOX, 360° TURN EITHER WAY (LEFT OR RIGHT), WALK OUT
- 9) WALK OVER

WALK (SCHRITT)
EXTENDED WALK	-----
JOG/TROT (TRAB)	- - - - -
EXTENDED TROT
LOPE (GALOPP)	—————
EXTENDED LOPE	—————
BACK UP (RÜCKWÄRTS)	~~~~~
LEAD CHANGE (GALOPPWECHSEL)	———
TURN (DREHUNG)	⊙
	ERSTE WESTERWEITER
	UNION WESTERWEITER
	WESTERWEITER WESTERWEITER

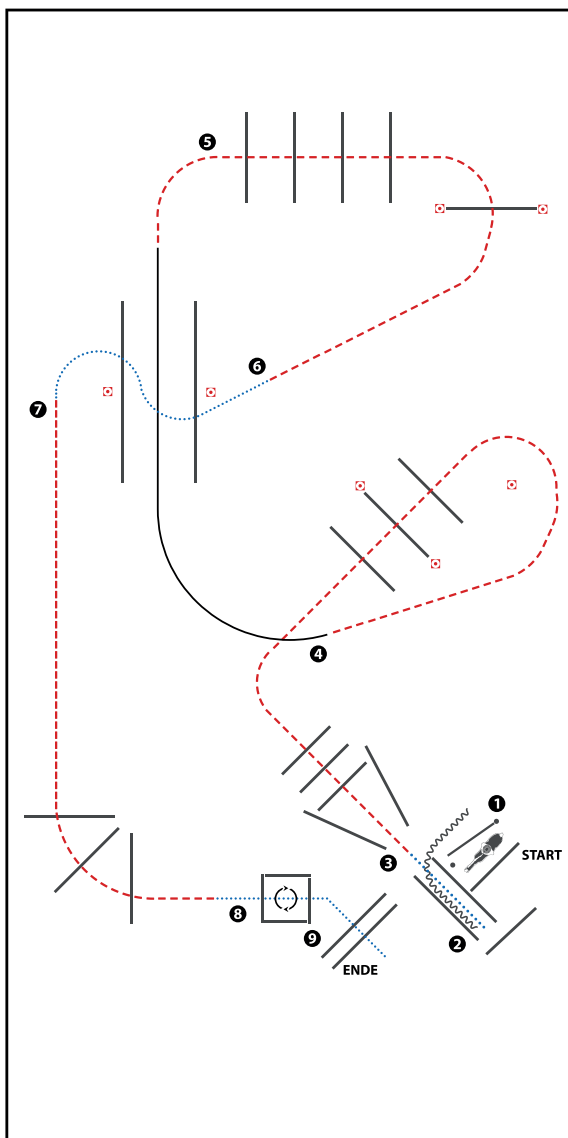

- 1) GATE (RH)
- 2) BACK UP, WALK OUT
- 3) JOG OVER
- 4) LOPE THRU CHUTE (RL) (Abstand 2m)
- 5) JOG OVER
- 6) WALK OVER
- 7) JOG OVER
- 8) STOP OR BREAK TO WALK, WALK INTO BOX, 360° TURN EITHER WAY (LEFT OR RIGHT), WALK OUT
- 9) WALK OVER

WALK (SCHRITT)
EXTENDED WALK	-----
JOG/TROT (TRAB)	-----
EXTENDED TROT	-----
LOPE (GALOPP)	-----
EXTENDED LOPE	-----
BACK UP (RÜCKWÄRTS)	~~~~~
LEAD CHANGE (GALOPPWECHSEL)	=====
TURN (DREHUNG)	⦿
	ERSTE WESTERWEITER UNION WIEDERHOLER

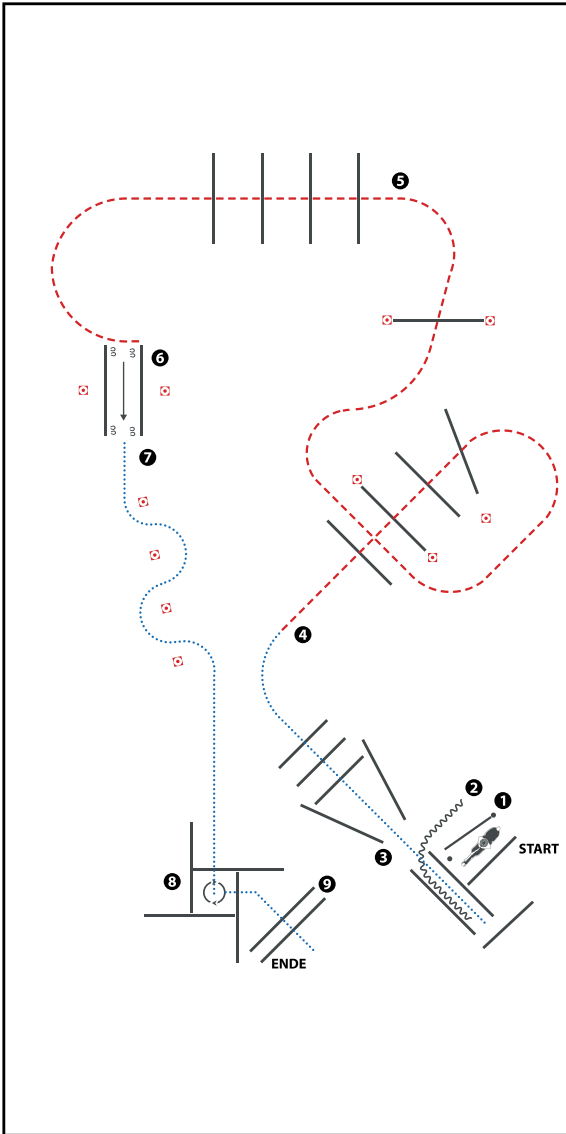

(Tor optional)

- 1) WALK, GATE (im Schritt zum Tor, Tor durchreiten)
- 2) BACK UP, WALK OUT (Rückwärts, im Schritt aus der Gasse)
- 3) WALK OVER (Schrittstangen)
- 4) JOG OVER (Trabstangen)
- 5) JOG OVER, STOP (Trabstangen, Anhalten)
- 6) SIDEPASS (Seitwärts)
- 7) WALK SERPENTINE, WALK INTO BOX
(Schritt Slalom, im Schritt in die Box)
- 8) 270° TURN RIGHT, WALK OUT (270° Wendung nach rechts,
im Schritt aus der Box)
- 9) WALK OVER (Schrittstangen)

WALK (SCHRITT)	
EXTENDED WALK	
JOG/TROT (TRAB)	
EXTENDED TROT	
LOPE (GALOPP)	
EXTENDED LOPE	
BACK UP (RÜCKWÄRTS)	
LEAD CHANGE (GALOPPWECHSEL)	
TURN (DREHUNG)	
	ERSTE
	WESTENREITER
	UNION
	WELDPFERDEBUND

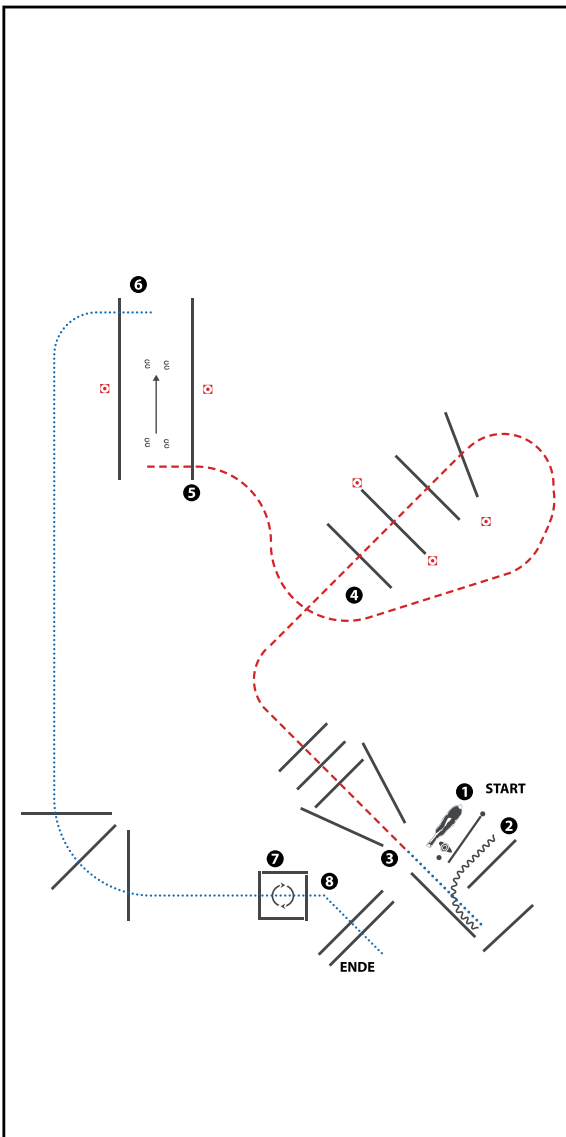

- 1) WALK, GATE (LH)
- 2) BACK UP, WALK OUT
- 3) JOG OVER
- 4) JOG OVER
- 5) JOG OVER, STOP BETWEEN POLES, SIDEPASS RIGHT, WALK OUT
- 6) WALK OVER, WALK INTO BOX
- 7) 360° TURN RIGHT, WALK OUT
- 8) WALK OVER

WALK (SCHRITT)
EXTENDED WALK	-----
JOG/TROT (TRAB)	-----
EXTENDED TROT	-----
LOPE (GALOPP)	-----
EXTENDED LOPE	-----
BACK UP (RÜCKWÄRTS)	~~~~~
LEAD CHANGE (GALOPPWECHSEL)	=====
TURN (DREHUNG)	⤵
	ERSTE
	WESTFALEN
	UNION
	WESTFALISCHES WILDEBEUTEL

Trail Set 3

Pattern 1-8

Arenagröße mind. 20 x 40 m

Für TH-Pattern gelten folgende Abstände und Maße:

WALK / WALK OVER	Abstand 40 - 60 cm • Erhöhung max. 30 cm. Bei Erhöhung sollte der Mindestabstand 55 cm betragen.
JOG / JOG OVER	Abstand 90 - 105 cm • Erhöhung max. 20 cm.
EXTENDED JOG	Abstand 105 - 125 cm.
LOPE / LOPE OVER	Abstand 180 - 210 cm • Erhöhung max. 20 cm.
EXTENDED LOPE	Abstand 210 - 225 cm.
BACK UP	Abstandmind. 100 cm, Erhöhung max. 30 cm.
SIDEPASS	Abstand in einer Gasse mind. 200 cm (ganzes Pferd), mind. 60 cm (1 Beinpaar zwischen zwei Stangen), Erhöhung max. 30 cm.
SERPENTIN WALK	Abstand mind. 200 cm
SERPENTIN JOG	Abstand mind. 250 cm
GATE	Breite mind. 90 cm, Länge 250 cm,
BRIDGE	Breite mind. 150 cm, Länge 250 cm,
BRIDGE WITH RAILING	Breite mind. 150 cm, Länge 250 cm,
BOX	Abstand 180 - 210 cm
JUMP	Erhöhung max. 45 cm

Zwischen den Hindernissen sollte eine:

Trabstrecke von mind. 10,00 m

Galoppstrecke von mind. 20,00 m

Volten sollten für Reiter der LK 5 und 4 nicht weniger als 12,00 m Durchmesser,
für LK 1 bis 3 nicht weniger als 10,00 m betragen

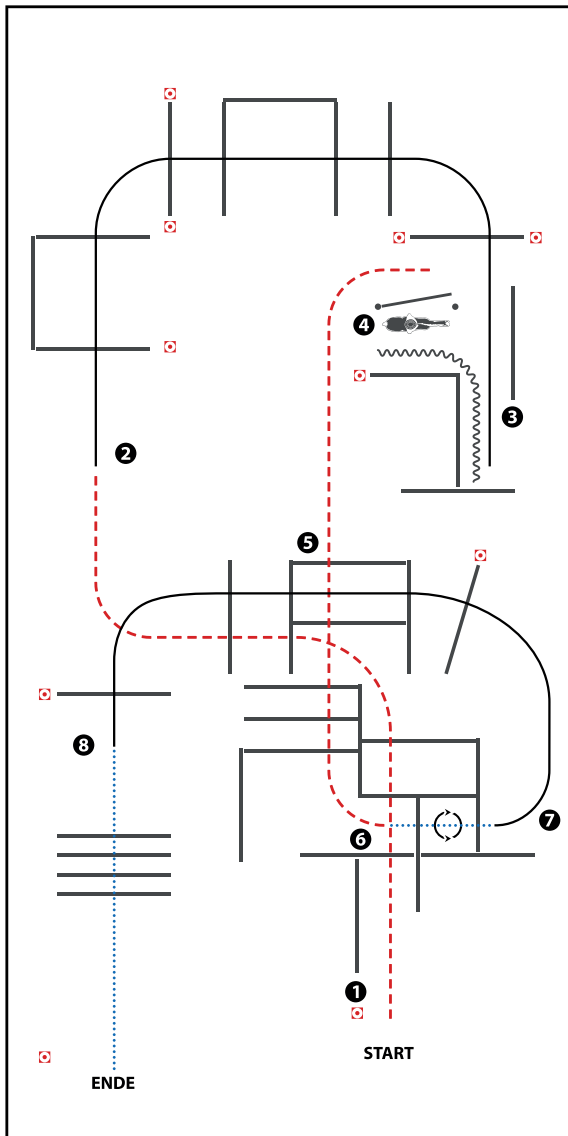

(Erhöhungen optional)

- 1) JOG OVER
- 2) LOPE OVER (RL)
- 3) LOPE INTO CHUTE, BACK UP
- 4) GATE (LH), JOG
- 5) JOG OVER
- 6) WALK INTO BOX, 360° TURN EITHER WAY (LEFT OR RIGHT), WALK OUT
- 7) LOPE OVER (LL)
- 8) STOP OR BREAK TO WALK, WALK OVER

WALK (SCHRITT)	
EXTENDED WALK	
JOE/TROT (TRAB)	
EXTENDED TROT	
LOPE (GALOPP)	
EXTENDED LOPE	
BACK UP (RÜCKWÄRTS)	
LEAD CHANGE (GALOPPWECHSEL)	
TURN (DREHUNG)	
	ERSTE
	WESTENREITER
	UNION
	WELDPFERDEBUND WESTENREITER

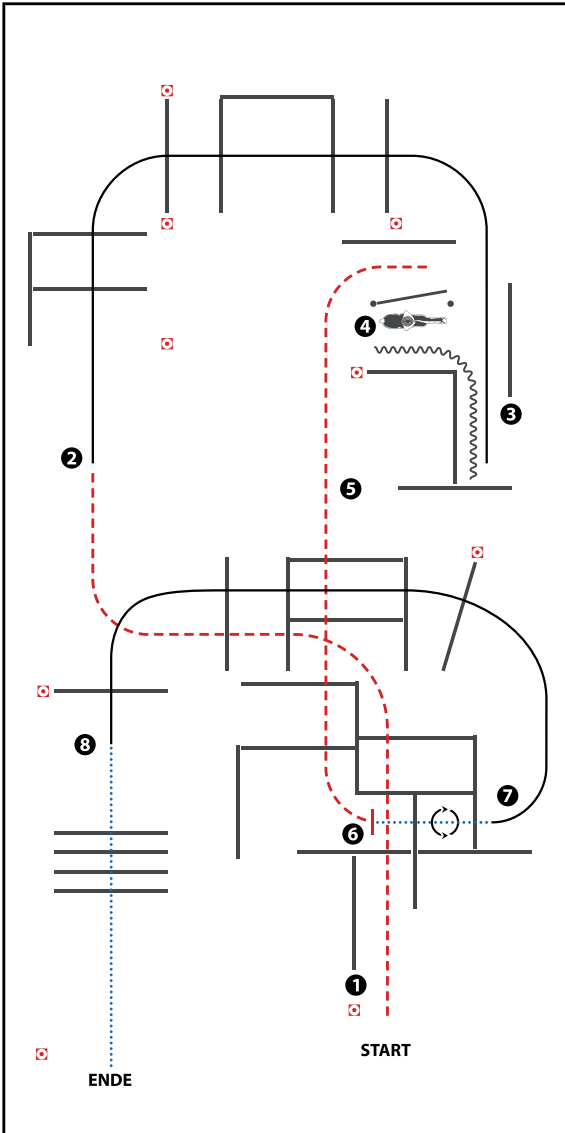

(Erhöhungen optional)

- 1) JOG OVER
- 2) LOPE OVER (RL)
- 3) LOPE INTO CHUTE, BACK UP
- 4) GATE (LH), JOG OUT
- 5) JOG OVER
- 6) STOP OR BREAK TO WALK, WALK INTO BOX, 360° TURN EITHER WAY (LEFT OR RIGHT), WALK OUT
- 7) LOPE OVER (LL)
- 8) STOP OR BREAK TO WALK, WALK OVER

WALK (SCHRITT)	
EXTENDED WALK	
JOG/TROT (TRAB)	
EXTENDED TROT	
LOPE (GALOPP)	
EXTENDED LOPE	
BACK UP (RÜCKWÄRTS)	
LEAD CHANGE (GALOPPWECHSEL)	
TURN (DREHUNG)	
	ERSTE
	WESTENREITER
	UNION
	WELDPFERDEBUND WESTENREITER

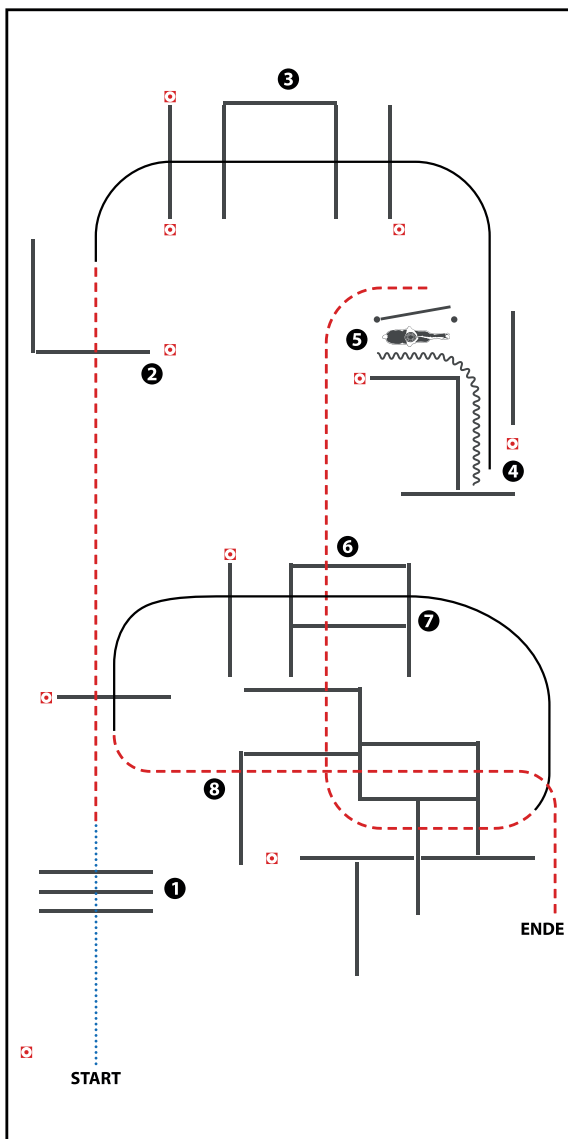

(Erhöhungen optional)

- 1) WALK OVER
- 2) JOG OVER
- 3) LOPE OVER (RL), LOPE INTO CHUTE, STOP
- 4) BACK UP
- 5) GATE
- 6) JOG OVER
- 7) LOPE OVER (LL)
- 8) JOG OVER

WALK (SCHRITT)
EXTENDED WALK
JOG/TROT (TRAB)
EXTENDED TROT
LOPE (GALOPP)
EXTENDED LOPE
BACK UP (RÜCKWÄRTS)	~~~~~
LEAD CHANGE (GALOPPWECHSEL)	=====
TURN (DREHUNG)	⤵
ERSTE	=====
WESTENREITER	=====
UNION	=====
WESTENREITER UND WESTENREITER	=====

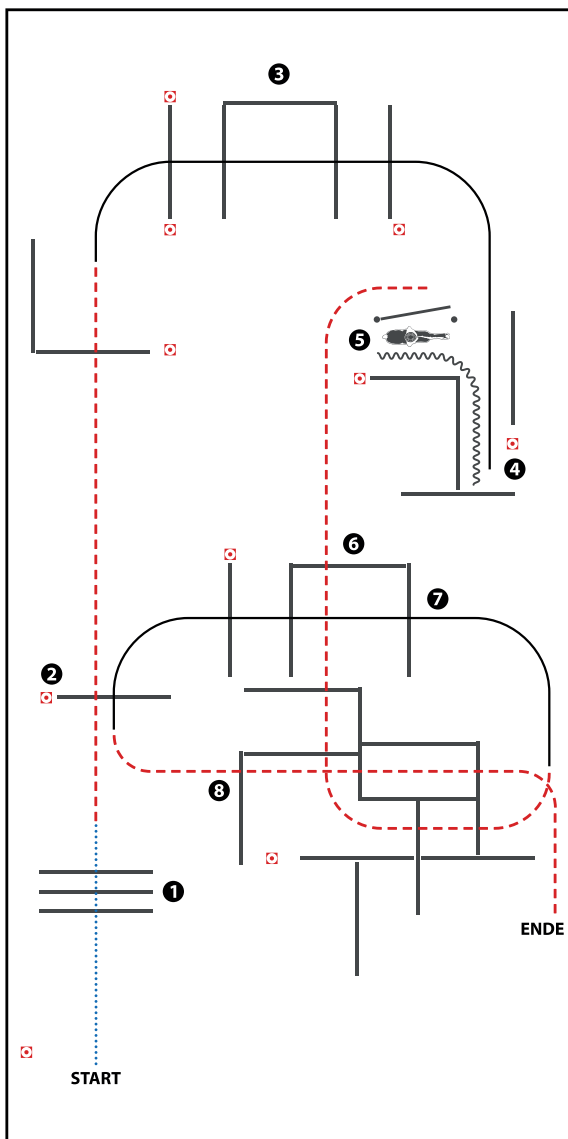

(Erhöhungen optional)

- 1) WALK OVER
- 2) JOG OVER
- 3) LOPE OVER (RL), LOPE INTO CHUTE, STOP
- 4) BACK UP
- 5) GATE
- 6) JOG OVER
- 7) LOPE OVER (LL)
- 8) JOG OVER

WALK (SCHRITT)	
EXTENDED WALK	
JOG/TROT (TRAB)	
EXTENDED TROT	
LOPE (GALOPP)	
EXTENDED LOPE	
BACK UP (RÜCKWÄRTS)	
LEAD CHANGE (GALOPPWECHSEL)	
TURN (DREHUNG)	
	ERSTE
	WESTENREITER
	UNION
	WIRTSCHAFTSUNIVERSITÄT

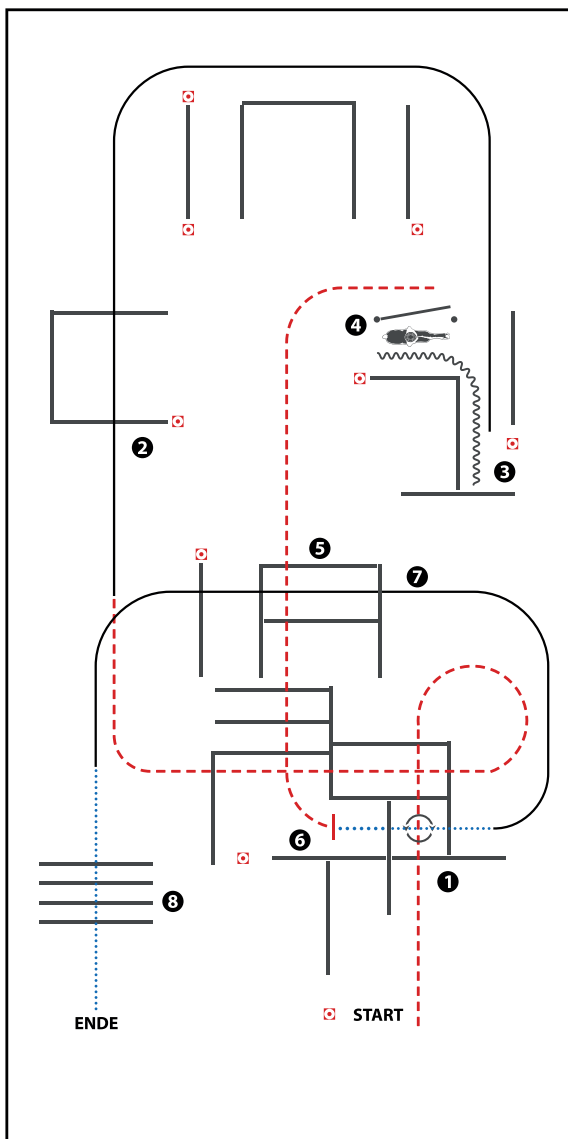

(Erhöhungen optional)

- 1) JOG OVER
- 2) LOPE OVER (RL), LOPE INTO CHUTE, STOP
- 3) BACK UP
- 4) GATE
- 5) JOG OVER
- 6) STOP OR BREAK TO WALK, WALK INTO BOX,
360° TURN EITHER WAY (LEFT OR RIGHT), WALK OUT
- 7) LOPE OVER (LL)
- 8) WALK OVER

WALK (SCHRITT)	
EXTENDED WALK	
JOG/TROT (TRAB)	
EXTENDED TROT	
LOPE (GALOPP)	
EXTENDED LOPE	
BACK UP (RÜCKWÄRTS)	
LEAD CHANGE (GALOPPWECHSEL)	
TURN (DREHUNG)	
ERSTE	
WESTENREITER	
UNION	
WIEDERHOLER/REITER	

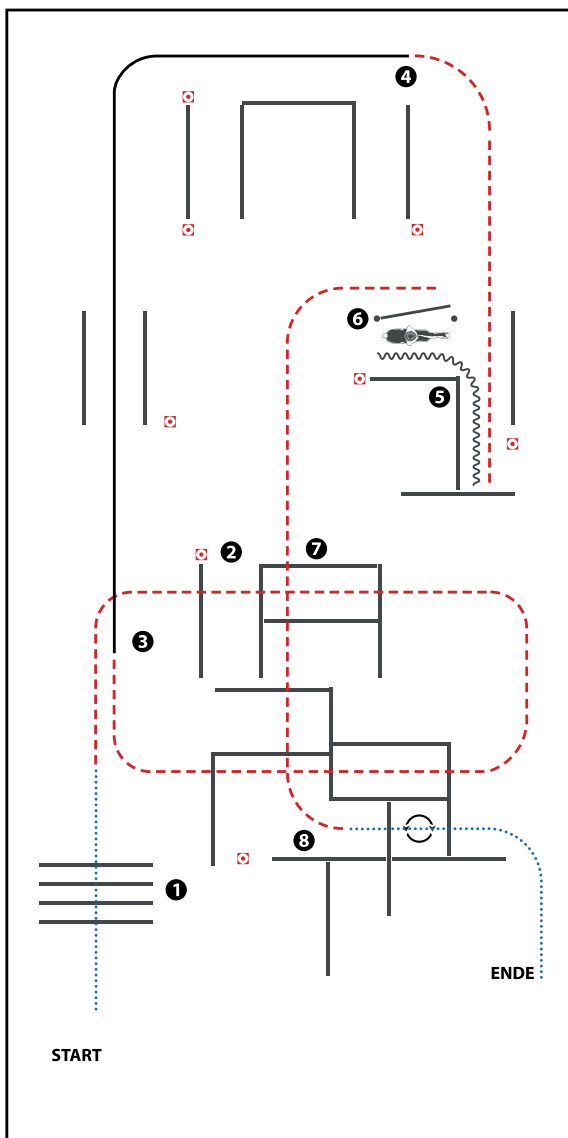

- 1) WALK OVER
- 2) JOG OVER
- 3) LOPE (RL)
- 4) JOG, JOG IN, STOP
- 5) BACK UP
- 6) GATE
- 7) JOG OVER
- 8) STOP OR BREAK TO WALK, WALK INTO BOX,
360° TURN EITHER WAY (LEFT OR RIGHT), WALK OUT

WALK (SCHRITT)	
EXTENDED WALK	
JOG/TROT (TRAB)	
EXTENDED TROT	
LOPE (GALOPP)	
EXTENDED LOPE	
BACK UP (RÜCKWÄRTS)	
LEAD CHANGE (GALOPPWECHSEL)	
TURN (DREHUNG)	
ERSTE	
WESTENREITER	
UNION	
WELDFÖRDERNDE VEREINIGUNG	

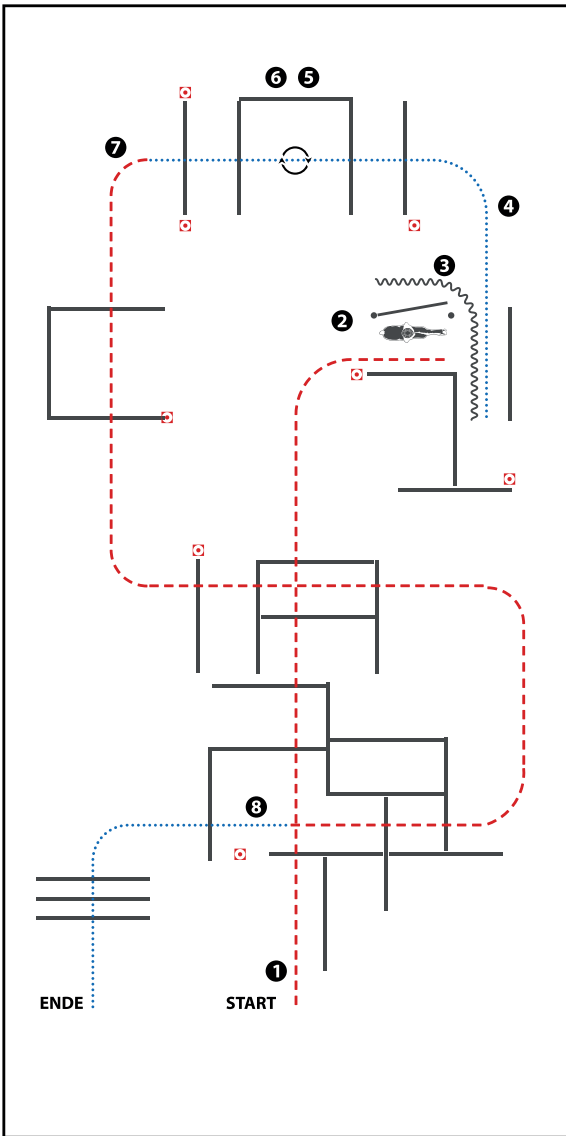

(Tor optional)

- 1) JOG OVER (Trabstangen)
- 2) GATE (Tor)
- 3) BACK UP, WALK OUT (Rückwärts, im Schritt aus der Gasse)
- 4) WALK OVER INTO BOX (Schrittstangen, im Schritt in die Box)
- 5) 360° TURN RIGHT (360° Wendung rechts)
- 6) WALK OVER (Schrittstangen)
- 7) JOG OVER (Trabstangen)
- 8) WALK OVER (Schrittstangen)

WALK (SCHRITT)	
EXTENDED WALK	
JOG/TROT (TRAB)	
EXTENDED TROT	
LOPE (GALOPP)	
EXTENDED LOPE	
BACK UP (RÜCKWÄRTS)	
LEAD CHANGE (GALOPPWECHSEL)	
TURN (DREHUNG)	
	ERSTE
	WESTENREITER
	UNION
	WELDPFERDEBUND WELDPFERDE

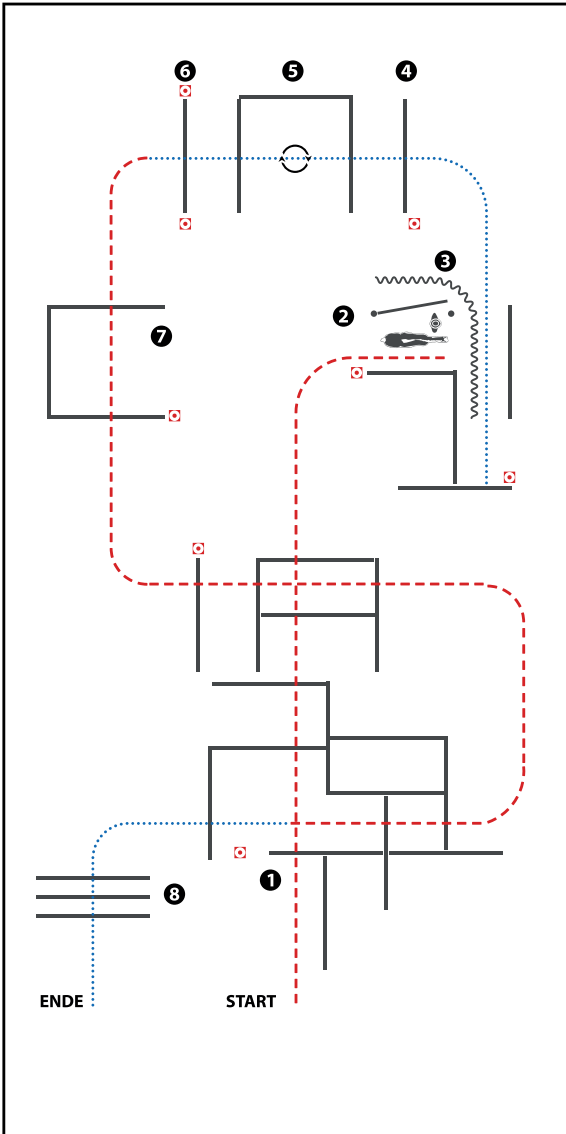

- 1) JOG OVER
- 2) GATE
- 3) BACK UP
- 4) WALK OVER INTO BOX
- 5) 360° TURN RIHGT
- 6) WALK OVER
- 7) JOG OVER
- 8) WALK OVER

WALK (SCHRITT)	
EXTENDED WALK	
JOE/TROT (TRAB)	
EXTENDED TROT	
LOPE (GALOPP)	
EXTENDED LOPE	
BACK UP (RÜCKWÄRTS)	
LEAD CHANGE (GALOPPWECHSEL)	
TURN (DREHUNG)	
	ERSTE
	WESTENREITER
	UNION
	WELDPFERDEBUND WELDPFERTEUR

Trail Set 4 mit Brücke

Pattern 1-14

Arenagröße mind. 25 x 50 m

Für TH-Pattern gelten folgende Abstände und Maße:

WALK / WALK OVER	Abstand 40 - 60 cm • Erhöhung max. 30 cm. Bei Erhöhung sollte der Mindestabstand 55 cm betragen.
JOG / JOG OVER	Abstand 90 - 105 cm • Erhöhung max. 20 cm.
EXTENDED JOG	Abstand 105 - 125 cm.
LOPE / LOPE OVER	Abstand 180 - 210 cm • Erhöhung max. 20 cm.
EXTENDED LOPE	Abstand 210 - 225 cm.
BACK UP	Abstandmind. 100 cm, Erhöhung max. 30 cm.
SIDEPASS	Abstand in einer Gasse mind. 200 cm (ganzes Pferd), mind. 60 cm (1 Beinpaar zwischen zwei Stangen), Erhöhung max. 30 cm.
SERPENTIN WALK	Abstand mind. 200 cm
SERPENTIN JOG	Abstand mind. 250 cm
GATE	Breite mind. 90 cm, Länge 250 cm,
BRIDGE	Breite mind. 150 cm, Länge 250 cm,
BRIDGE WITH RAILING	Breite mind. 150 cm, Länge 250 cm,
BOX	Abstand 180 - 210 cm
JUMP	Erhöhung max. 45 cm

Zwischen den Hindernissen sollte eine:

Trabstrecke von mind. 10,00 m

Galoppstrecke von mind. 20,00 m

Volten sollten für Reiter der LK 5 und 4 nicht weniger als 12,00 m Durchmesser,
für LK 1 bis 3 nicht weniger als 10,00 m betragen

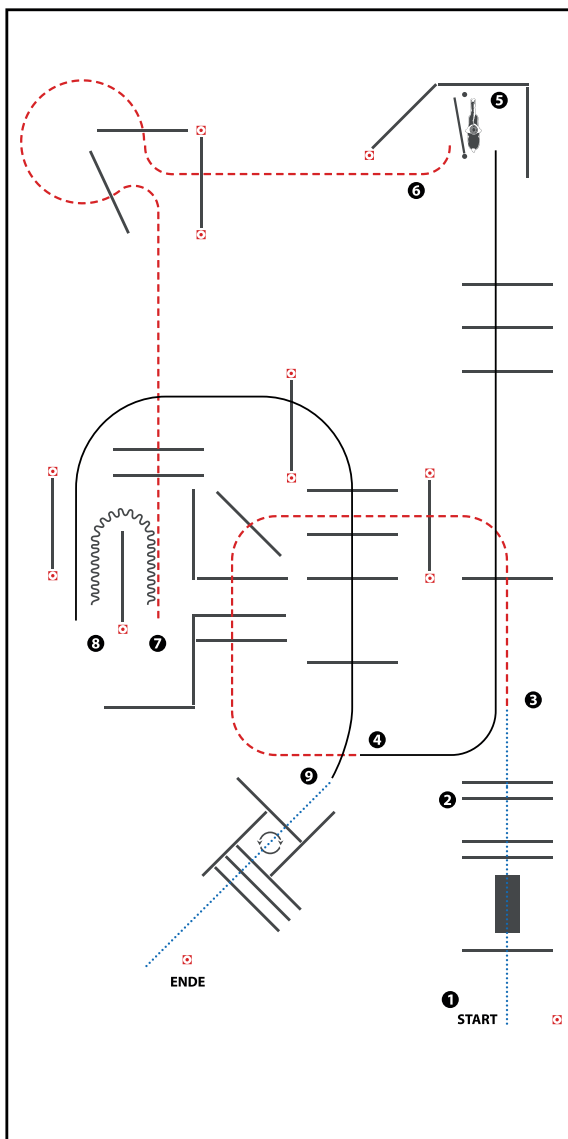

(Erhöhungen optional)

- 1) WALK OVER POLE AND BRIDGE, WALK OVER 2 POLES
- 2) WALK OVER 2 POLES
- 3) JOG OVER
- 4) LOPE OVER (LL)
- 5) GATE
- 6) JOG OVER, JOG INTO CHUTE
- 7) BACK UP
- 8) LOPE OUT, LOPE OVER (RL)
- 9) STOP OR BREAK TO WALK, WALK INTO BOX, 360° TURN EITHER WAY (LEFT OR RIGHT), WALK OVER

WALK (SCHRITT)	
EXTENDED WALK	
JOG/TROT (TRAB)	
EXTENDED TROT	
LOPE (GALOPP)	
EXTENDED LOPE	
BACK UP (RÜCKWÄRTS)	
LEAD CHANGE (GALOPPWECHSEL)	
TURN (DREHUNG)	
	ERSTE
	WESTENREITER
	UNION
	WIRTSCHAFTSUNIVERSITÄT

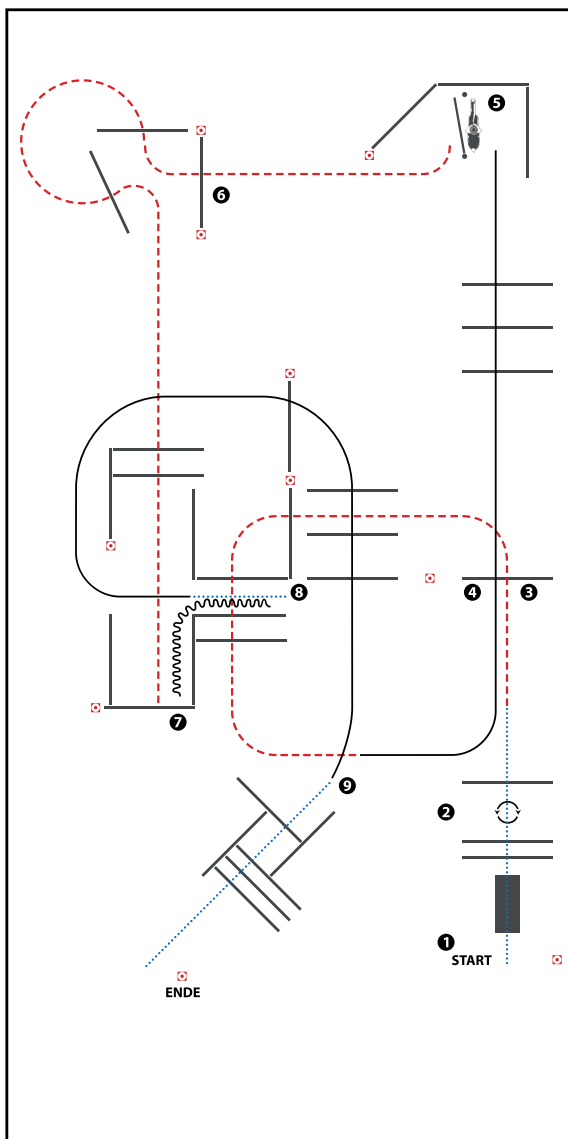

(Erhöhungen optional)

- 1) BRIDGE
- 2) WALK OVER, STOP BETWEEN POLES, 360° TURN EITHER WAY (LEFT OR RIGHT), WALK OVER
- 3) JOG OVER
- 4) LOPE OVER (LL)
- 5) GATE
- 6) JOG OVER, JOG INTO CHUTE
- 7) BACK UP
- 8) WALK OUT, LOPE OVER (RL)
- 9) STOP OR BREAK TO WALK, WALK OVER

WALK (SCHRITT)
EXTENDED WALK
JOG/TROT (TRAB)	-----
EXTENDED TROT	-----
LOPE (GALOPP)	=====
EXTENDED LOPE	=====
BACK UP (RÜCKWÄRTS)	~~~~~
LEAD CHANGE (GALOPPWECHSEL)	=====
TURN (DREHUNG)	⊙
	ERSTE WESTENREITER UNION WIRTSCHAFTSUNIVERSITÄT SIEGEN

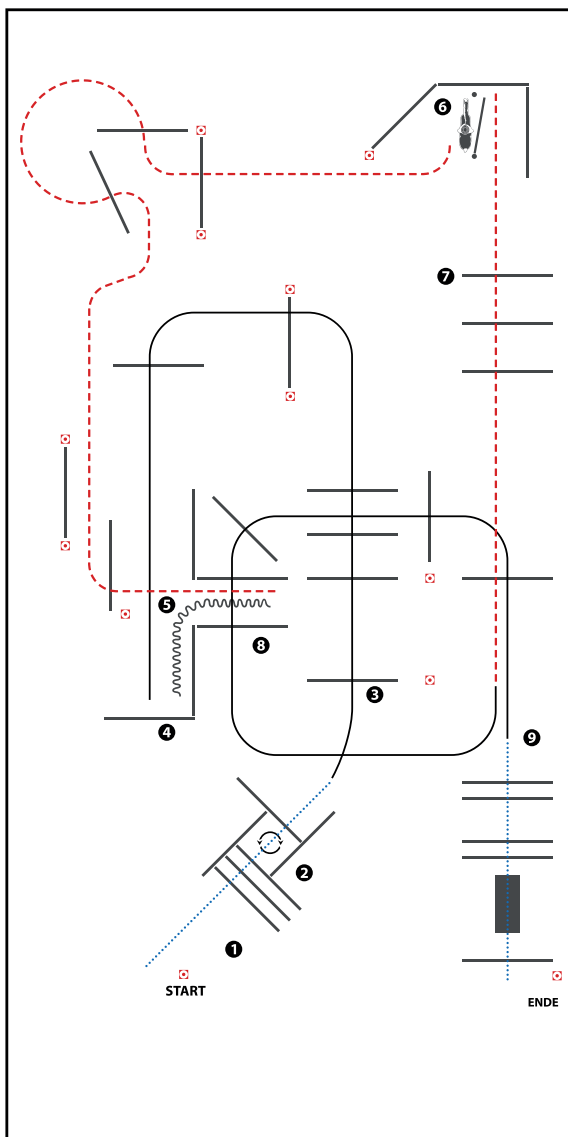

(Erhöhungen optional)

- 1) WALK OVER, WALK INTO BOX
- 2) 360° TURN EITHER WAY (LEFT OR RIGHT), WALK OUT
- 3) LOPE OVER (LL)
- 4) BACK UP
- 5) JOG OUT, JOG OVER
- 6) GATE
- 7) JOG OVER
- 8) LOPE OVER (RL)
- 9) STOP OR BREAK TO WALK, WALK OVER POLES AND BRIDGE

WALK (SCHRITT)	
EXTENDED WALK	
JOG/TROT (TRAB)	
EXTENDED TROT	
LOPE (GALOPP)	
EXTENDED LOPE	
BACK UP (RÜCKWÄRTS)	
LEAD CHANGE (GALOPPWECHSEL)	
TURN (DREHUNG)	
ERSTE	
WESTENREITER	
UNION	
WELDPFERDEBUND WESTENREITER	

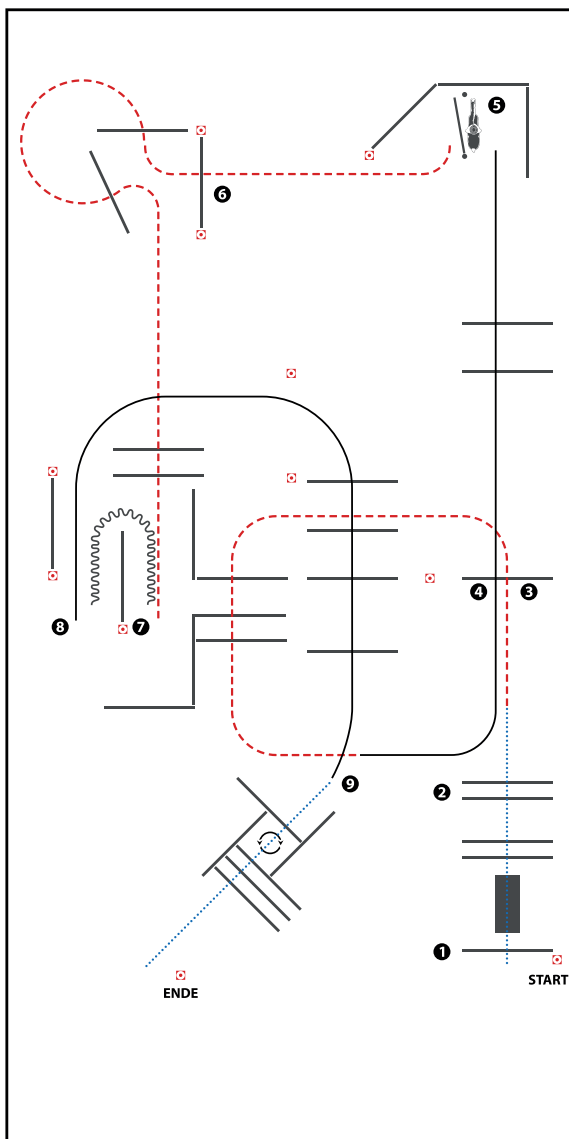

(Erhöhungen optional)

- 1) WALK OVER POLE AND BRIDGE, WALK OVER 2 POLES
- 2) WALK OVER 2 POLES
- 3) JOG OVER
- 4) LOPE OVER (LL)
- 5) GATE
- 6) JOG OVER, JOG INTO CHUTE
- 7) BACK UP
- 8) LOPE OUT, LOPE OVER (RL)
- 9) STOP OR BREAK TO WALK, WALK INTO BOX, 360° TURN EITHER WAY (LEFT OR RIGHT), WALK OVER

WALK (SCHRITT)
EXTENDED WALK
JOG/TROT (TRAB)	-----
EXTENDED TROT	-----
LOPE (GALOPP)	=====
EXTENDED LOPE	=====
BACK UP (RÜCKWÄRTS)	~~~~~
LEAD CHANGE (GALOPPWECHSEL)	=====
TURN (DREHUNG)	⊙
	ERSTE WESTENREITER UNION WIEDERGESCHENKT

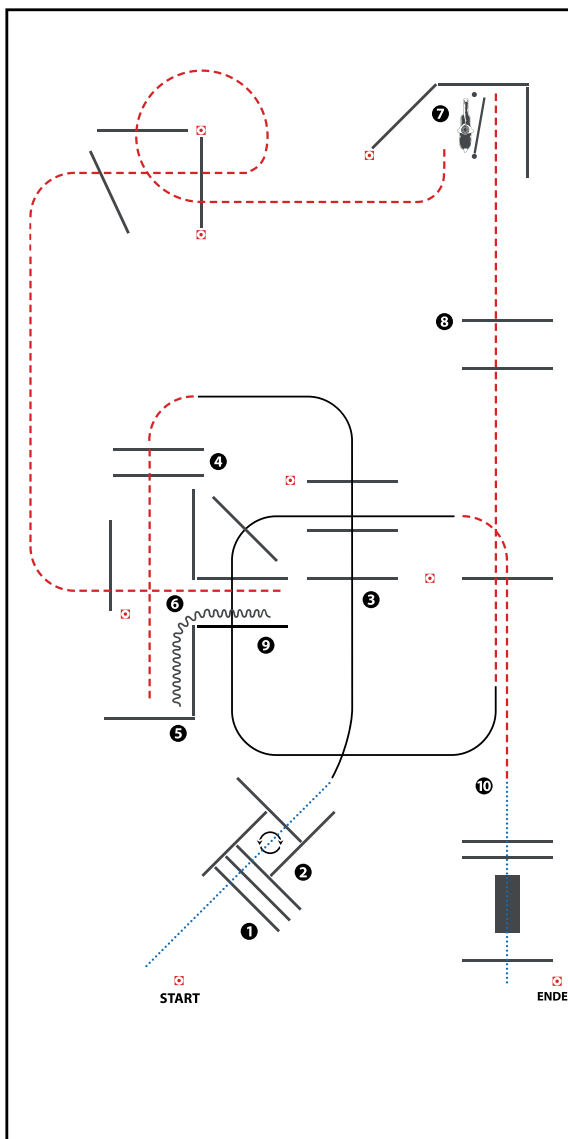

(Erhöhungen optional)

- 1) WALK OVER, WALK INTO BOX
- 2) 360° TURN EITHER WAY (LEFT OR RIGHT), WALK OUT
- 3) LOPE OVER (LL)
- 4) JOG OVER, JOG INTO CHUTE
- 5) BACK UP
- 6) JOG OUT, JOG OVER
- 7) GATE
- 8) JOG OVER
- 9) LOPE OVER (RL), JOG OVER
- 10) STOP OR BREAK TO WALK, WALK OVER POLES AND BRIDGE

WALK (SCHRITT)	
EXTENDED WALK	
JOG/TROT (TRAB)	
EXTENDED TROT	
LOPE (GALOPP)	
EXTENDED LOPE	
BACK UP (RÜCKWÄRTS)	
LEAD CHANGE (GALOPPWECHSEL)	
TURN (DREHUNG)	
	ERSTE
	WESTBREITER
	UNION
	WIEDERGESCHLOSSEN

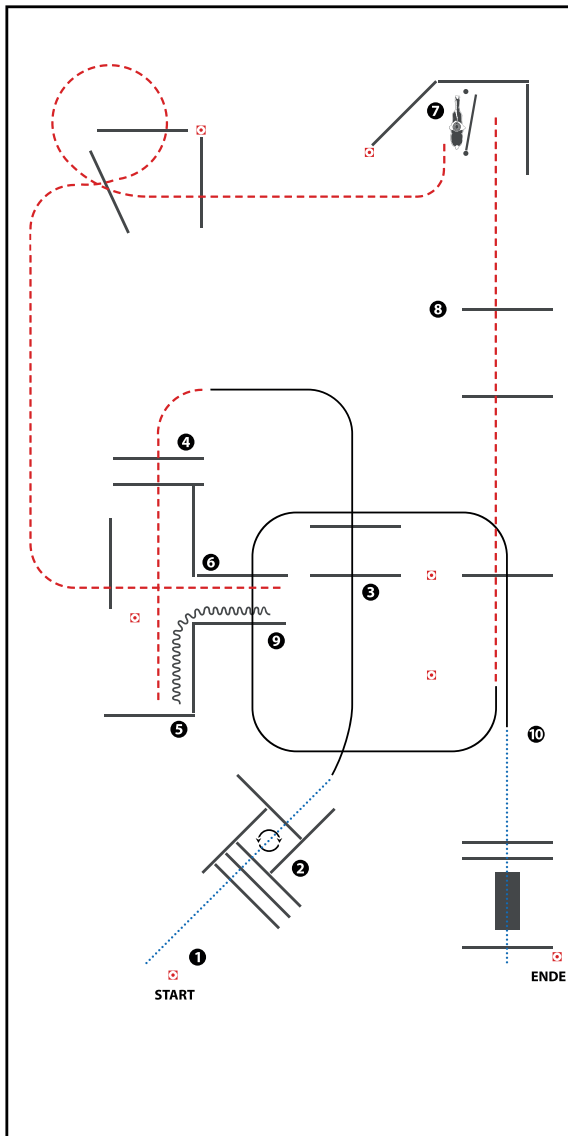

(Erhöhungen optional)

- 1) WALK OVER, WALK INTO BOX
- 2) 360° TURN EITHER WAY (LEFT OR RIGHT), WALK OUT
- 3) LOPE OVER (LL)
- 4) JOG OVER, JOG INTO CHUTE
- 5) BACK UP
- 6) JOG OUT, JOG OVER
- 7) GATE
- 8) JOG OVER
- 9) LOPE OVER (RL)
- 10) STOP OR BREAK TO WALK, WALK OVER POLES AND BRIDGE

WALK (SCHRITT)
EXTENDED WALK
JOG/TROT (TRAB)	-----
EXTENDED TROT	-----
LOPE (GALOPP)	=====
EXTENDED LOPE	=====
BACK UP (RÜCKWÄRTS)	~~~~~
LEAD CHANGE (GALOPPWECHSEL)	=====
TURN (DREHUNG)	
ERSTE	
WESTENREITER	
UNION	
WESTENREITER	

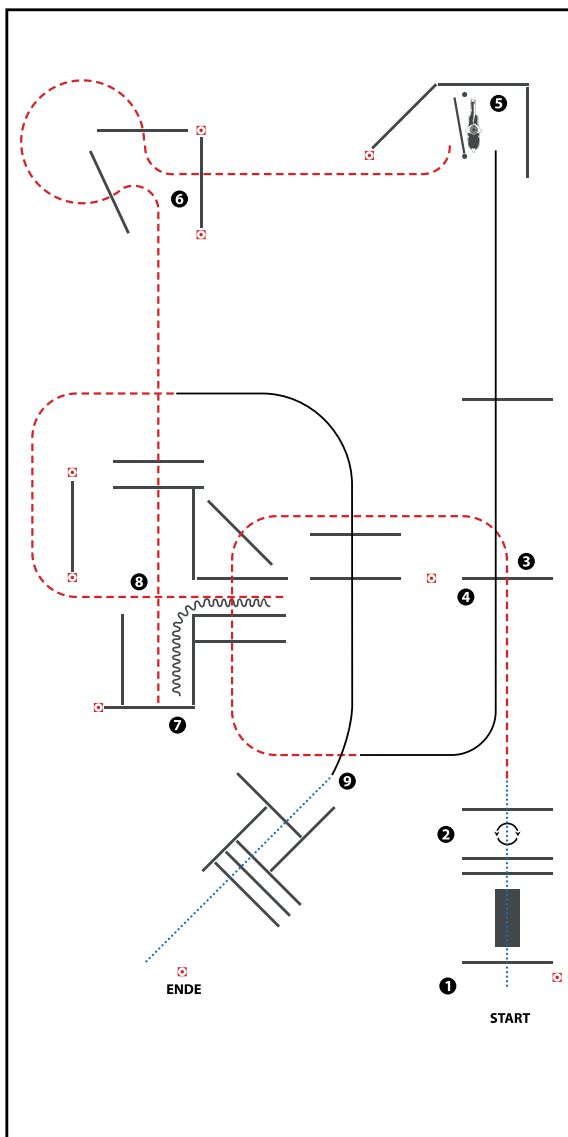

(Erhöhungen optional)

- 1) WALK OVER POLE AND BRIDGE
- 2) WALK OVER, STOP BETWEEN POLES,
360° TURN EITHER WAY (LEFT OR RIGHT), WALK OVER
- 3) JOG OVER
- 4) LOPE OVER (LL)
- 5) GATE
- 6) JOG OVER, JOG INTO CHUTE
- 7) BACK UP
- 8) JOG OUT, LOPE OVER (RL)
- 9) STOP OR BREAK TO WALK, WALK OVER

WALK (SCHRITT)	
EXTENDED WALK	
JOG/TROT (TRAB)	
EXTENDED TROT	
LOPE (GALOPP)	
EXTENDED LOPE	
BACK UP (RÜCKWÄRTS)	
LEAD CHANGE (GALOPPWECHSEL)	
TURN (DREHUNG)	
	ERSTE
	WESTENREITER
	UNION
	WELDPFERDEBUND

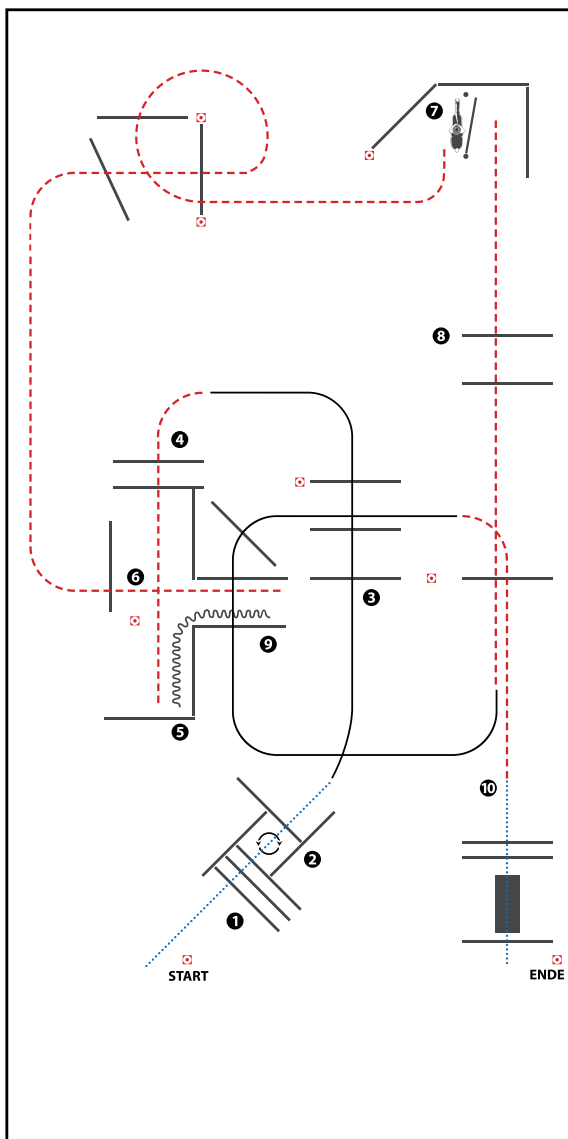

(Erhöhungen optional)

- 1) WALK OVER, WALK INTO BOX
- 2) 360° TURN EITHER WAY (LEFT OR RIGHT), WALK OUT
- 3) LOPE OVER (LL)
- 4) JOG OVER, JOG INTO CHUTE
- 5) BACK UP
- 6) JOG OUT, JOG OVER
- 7) GATE
- 8) JOG OVER
- 9) LOPE OVER (RL), JOG OVER
- 10) STOP OR BREAK TO WALK, WALK OVER POLES AND BRIDGE

WALK (SCHRITT)
EXTENDED WALK
JOG/TROT (TRAB)
EXTENDED TROT
LOPE (GALOPP)
EXTENDED LOPE
BACK UP (RÜCKWÄRTS)	~~~~~
LEAD CHANGE (GALOPPWECHSEL)
TURN (DREHUNG)
	ERSTE WESTENREITER
	UNION WIRTSCHAFTSCHAFTSCHAFT

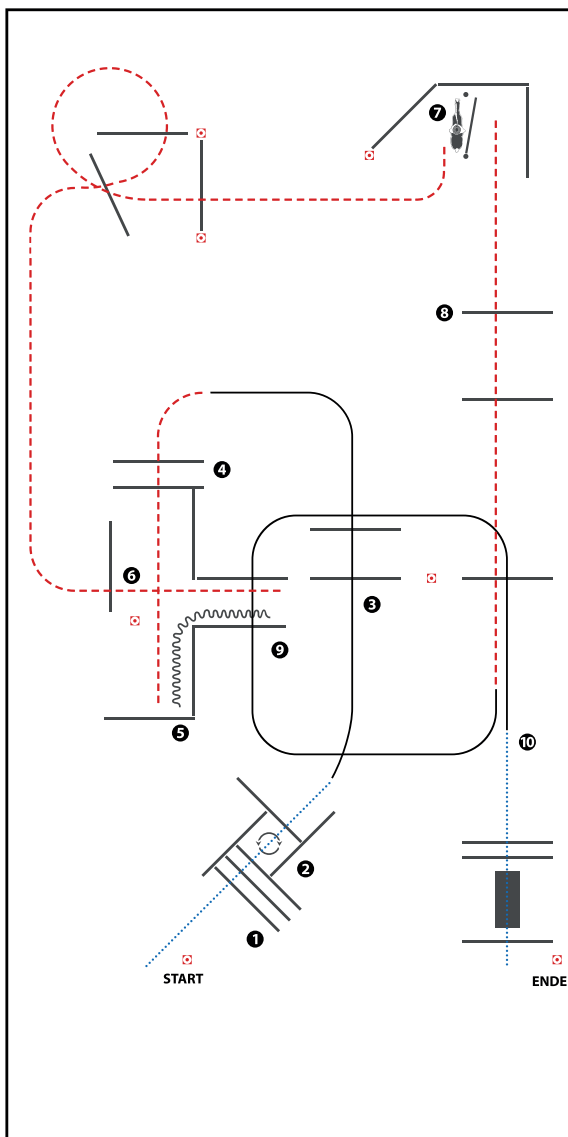

(Erhöhungen optional)

- 1) WALK OVER, WALK INTO BOX
- 2) 360° TURN EITHER WAY (LEFT OR RIGHT), WALK OUT
- 3) LOPE OVER (LL)
- 4) JOG OVER, JOG INTO CHUTE
- 5) BACK UP
- 6) JOG OUT, JOG OVER
- 7) GATE
- 8) JOG OVER
- 9) LOPE OVER (RL)
- 10) STOP OR BREAK TO WALK, WALK OVER POLES AND BRIDGE

WALK (SCHRITT)	
EXTENDED WALK	
JOG/TROT (TRAB)	
EXTENDED TROT	
LOPE (GALOPP)	
EXTENDED LOPE	
BACK UP (RÜCKWÄRTS)	
LEAD CHANGE (GALOPPWECHSEL)	
TURN (DREHUNG)	
ERSTE	
WESTENREITER	
UNION	
WELDPFERDEBUND WESTENREITER	

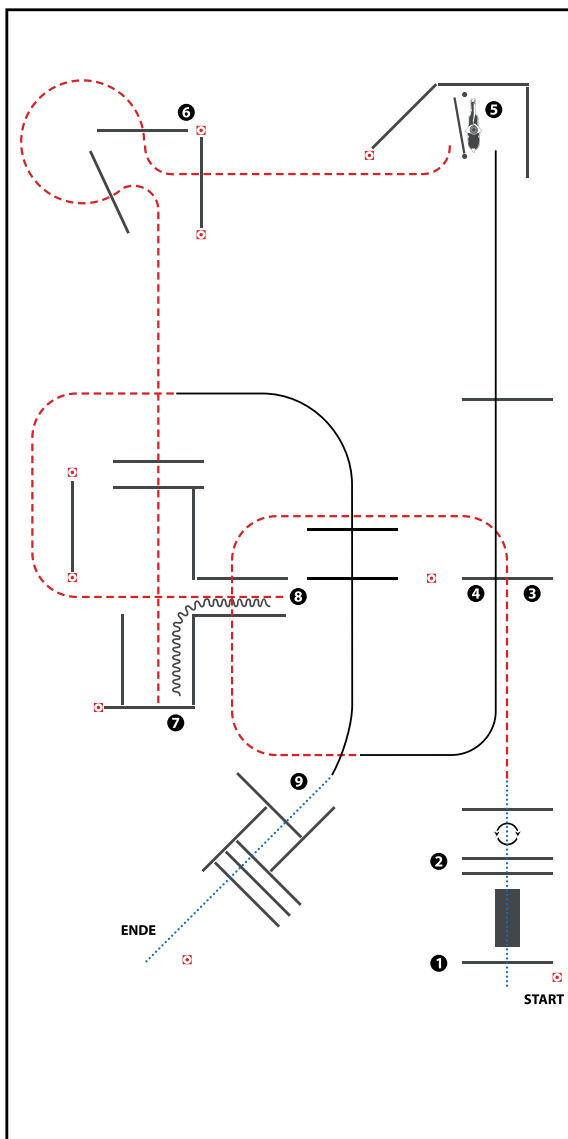

(Erhöhungen optional)

- 1) WALK OVER POLE AND BRIDGE
- 2) WALK OVER, STOP BETWEEN POLES, 360° TURN EITHER WAY (LEFT OR RIGHT), WALK OVER
- 3) JOG OVER
- 4) LOPE OVER (LL)
- 5) GATE
- 6) JOG OVER, JOG INTO CHUTE
- 7) BACK UP
- 8) JOG OUT, LOPE OVER (RL)
- 9) STOP OR BREAK TO WALK, WALK OVER

WALK (SCHRITT)
EXTENDED WALK
JOG/TROT (TRAB)	-----
EXTENDED TROT	-----
LOPE (GALOPP)	=====
EXTENDED LOPE	=====
BACK UP (RÜCKWÄRTS)	~~~~~
LEAD CHANGE (GALOPPWECHSEL)	=====
TURN (DREHUNG)	⊙
	ERSTE WESTENREITER UNION WIRTSCHAFTSVERBAND WESTENREITER

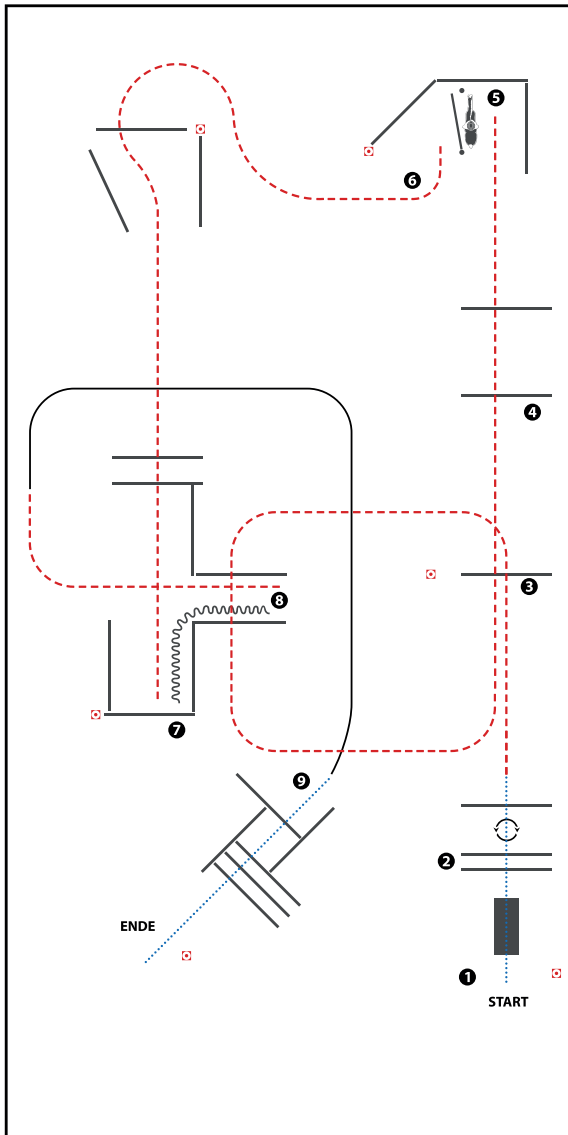

- 1) WALK OVER BRIDGE
- 2) WALK OVER, STOP BETWEEN POLES,
360° TURN EITHER WAY (LEFT OR RIGHT), WALK OVER
- 3) JOG OVER
- 4) JOG OVER
- 5) GATE
- 6) JOG OVER, JOG INTO CHUTE
- 7) BACK UP
- 8) JOG OUT, LOPE (RL)
- 9) STOP OR BREAK TO WALK, WALK OVER

WALK (SCHRITT)	
EXTENDED WALK	
JOG/TROT (TRAB)	
EXTENDED TROT	
LOPE (GALOPP)	
EXTENDED LOPE	
BACK UP (RÜCKWÄRTS)	
LEAD CHANGE (GALOPPWECHSEL)	
TURN (DREHUNG)	

ERSTE WESTENREITER
 UNION WIRTSCHAFTSCHAFTSCHAFT

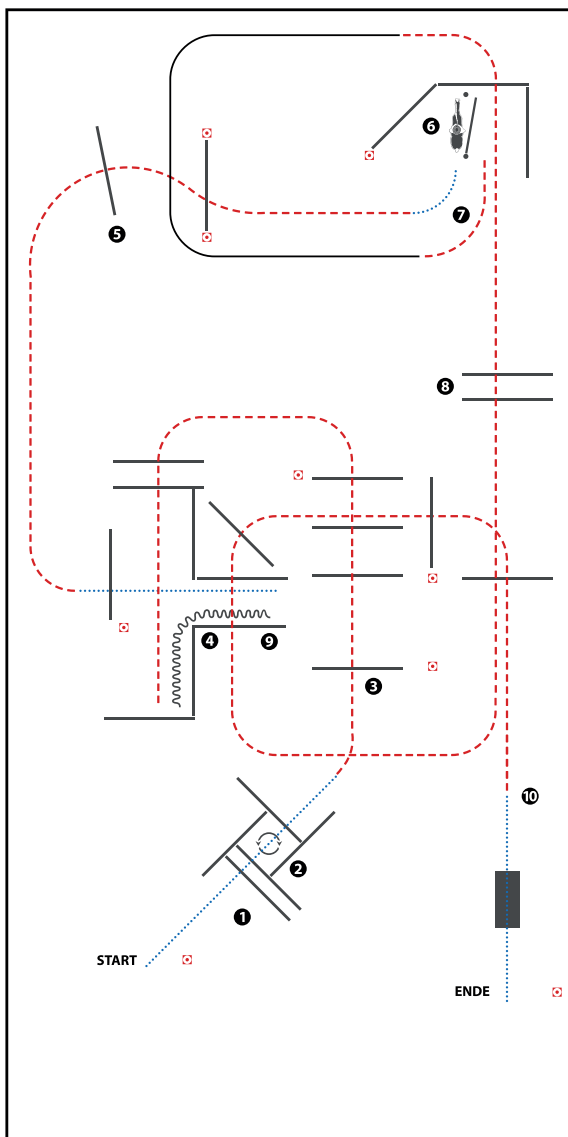

- 1) WALK OVER, WALK INTO BOX
- 2) 360° TURN EITHER WAY (LEFT OR RIGHT), WALK OUT
- 3) JOG OVER, JOG INTO CHUTE
- 4) BACK UP, WALK OUT, WALK OVER
- 5) JOG OVER, WALK
- 6) GATE
- 7) JOG, LOPE (RL)
- 8) JOG OVER
- 9) JOG OVER
- 10) WALK OVER BRIDGE

WALK (SCHRITT)
EXTENDED WALK	- - - - -
JOG/TROT (TRAB)	- . - . - .
EXTENDED TROT	- . - . - .
LOPE (GALOPP)	=====
EXTENDED LOPE	=====
BACK UP (RÜCKWÄRTS)	~~~~~
LEAD CHANGE (GALOPPWECHSEL)	=====
TURN (DREHUNG)	⤵
	ERSTE WESTENREITER
	UNION WIRTSCHAFTSCHAFTSCHAFT

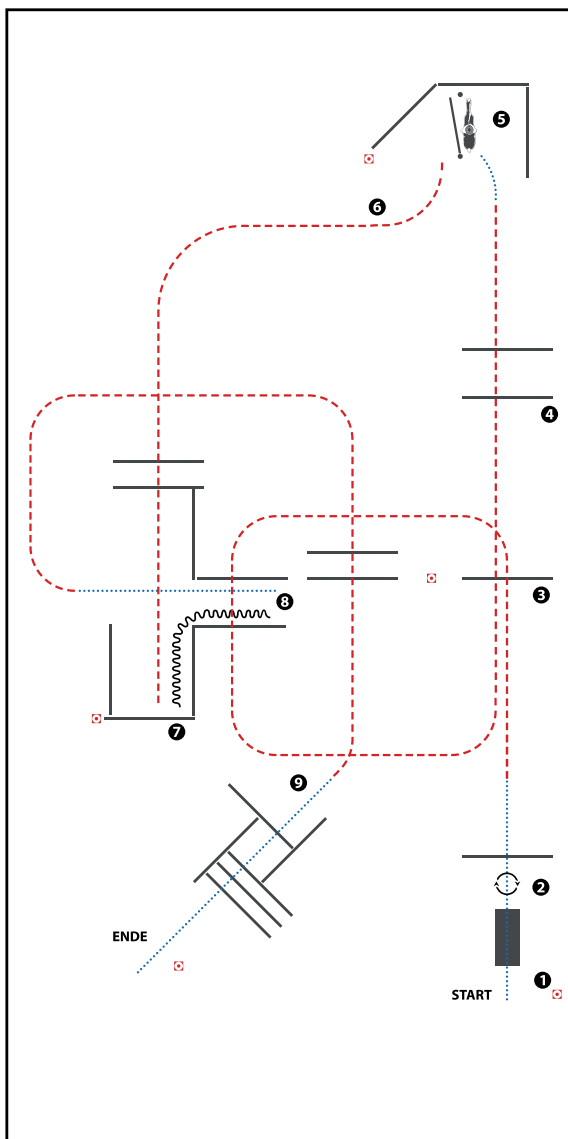

(Tor optional)

- 1) WALK OVER BRIDGE (Im Schritt über die Brücke)
- 2) STOP, 360° TURN RIGHT (Anhalten, 360° Wendung rechts), WALK OVER (Schrittstangen)
- 3) JOG OVER (Trabstangen)
- 4) JOG OVER, WALK (Trabstangen, Schritt)
- 5) GATE (Tor)
- 6) JOG OVER, JOG INTO CHUTE (Trabstangen, in Gasse traben)
- 7) BACK UP (Rückwärts)
- 8) WALK OUT, JOG OVER (im Schritt aus der Gasse, Trabstangen)
- 9) STOP OR BREAK TO WALK, WALK OVER (Anhalten oder Übergang zum Schritt, Schrittstangen)

WALK (SCHRITT)
EXTENDED WALK
JOG/TROT (TRAB)	-----
EXTENDED TROT	-----
LOPE (GALOPP)	=====
EXTENDED LOPE	=====
BACK UP (RÜCKWÄRTS)	~~~~~
LEAD CHANGE (GALOPPWECHSEL)	=====
TURN (DREHUNG)	⊙
ERSTE	=====
WESTENREITER	=====
UNION	=====
WORLDSPORTSBRAND	=====

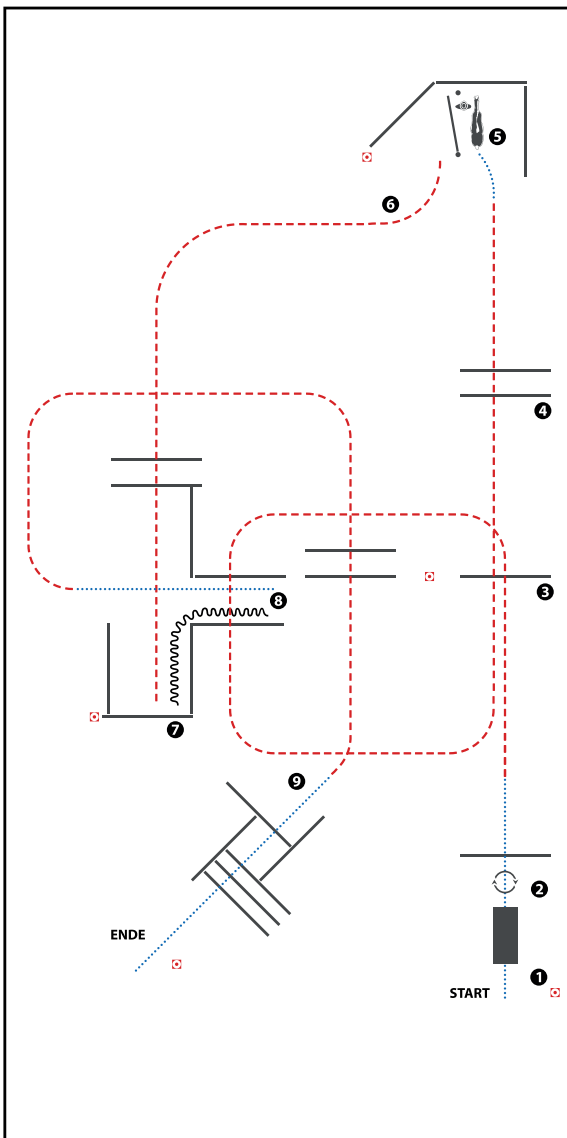

- 1) WALK OVER BRIDGE
- 2) STOP, 360° TURN RIGHT, WALK OVER
- 3) JOG OVER
- 4) JOG OVER, WALK
- 5) GATE
- 6) JOG OVER, JOG INTO CHUTE
- 7) BACK UP
- 8) WALK OUT, JOG OVER
- 9) STOP OR BREAK TO WALK, WALK OVER

WALK (SCHRITT)	
EXTENDED WALK	
JOG/TROT (TRAB)	
EXTENDED TROT	
LOPE (GALOPP)	
EXTENDED LOPE	
BACK UP (RÜCKWÄRTS)	
LEAD CHANGE (GALOPPWECHSEL)	
TURN (DREHUNG)	
	ERSTE
	WESTENREITER
	UNION
	WELDPFERDEBUND WESTENREITER

Trail Set 5

Pattern 1-11

Arenagröße mind. 25 x 50 m

Für TH-Pattern gelten folgende Abstände und Maße:

WALK / WALK OVER	Abstand 40 - 60 cm • Erhöhung max. 30 cm. Bei Erhöhung sollte der Mindestabstand 55 cm betragen.
JOG / JOG OVER	Abstand 90 - 105 cm • Erhöhung max. 20 cm.
EXTENDED JOG	Abstand 105 - 125 cm.
LOPE / LOPE OVER	Abstand 180 - 210 cm • Erhöhung max. 20 cm.
EXTENDED LOPE	Abstand 210 - 225 cm.
BACK UP	Abstandmind. 100 cm, Erhöhung max. 30 cm.
SIDEPASS	Abstand in einer Gasse mind. 200 cm (ganzes Pferd), mind. 60 cm (1 Beinpaar zwischen zwei Stangen), Erhöhung max. 30 cm.
SERPENTIN WALK	Abstand mind. 200 cm
SERPENTIN JOG	Abstand mind. 250 cm
GATE	Breite mind. 90 cm, Länge 250 cm,
BRIDGE	Breite mind. 150 cm, Länge 250 cm,
BRIDGE WITH RAILING	Breite mind. 150 cm, Länge 250 cm,
BOX	Abstand 180 - 210 cm
JUMP	Erhöhung max. 45 cm

Zwischen den Hindernissen sollte eine:

Trabstrecke von mind. 10,00 m

Galoppstrecke von mind. 20,00 m

Volten sollten für Reiter der LK 5 und 4 nicht weniger als 12,00 m Durchmesser,
für LK 1 bis 3 nicht weniger als 10,00 m betragen

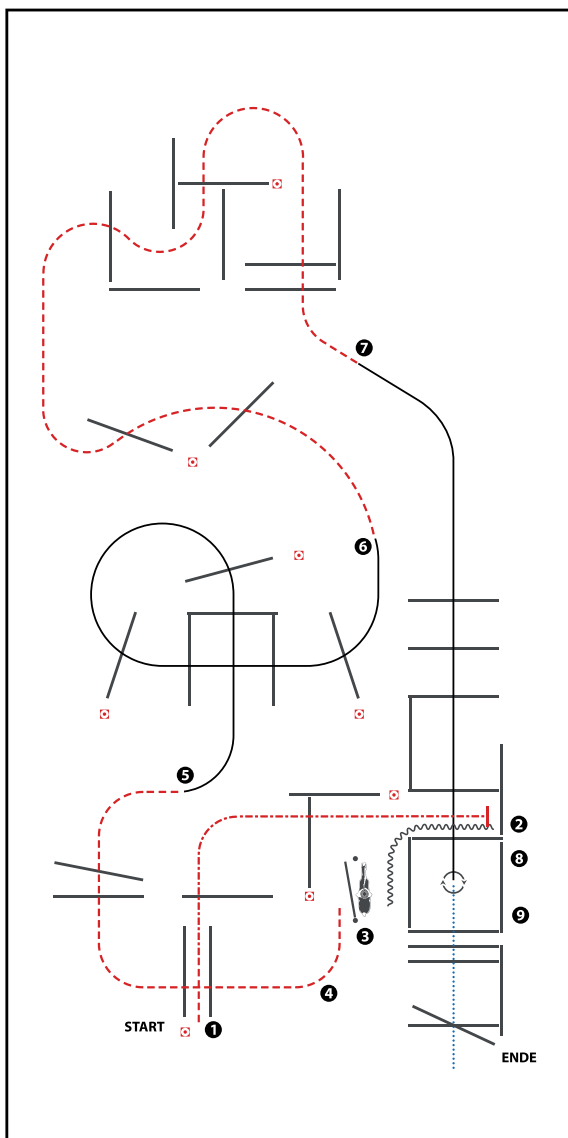

(Erhöhungen optional)

- 1) JOG, EXTENDED JOG OVER,
EXTENDED JOG INTO CHUTE, STOP
- 2) BACK UP
- 3) GATE (LH)
- 4) JOG OVER
- 5) LOPE OVER (LL)
- 6) JOG OVER
- 7) LOPE OVER (RL)
- 8) LOPE INTO BOX, STOP,
360° TURN EITHER WAY (LEFT OR RIGHT)
- 9) WALK OUT, WALK OVER

WALK (SCHRITT)	
EXTENDED WALK	
JOG/TROT (TRAB)	
EXTENDED TROT	
LOPE (GALOPP)	
EXTENDED LOPE	
BACK UP (RÜCKWÄRTS)	
LEAD CHANGE (GALOPPWECHSEL)	
TURN (DREHUNG)	
	ERSTE
	WESTENREITER
	UNION
	WELDPFERDEBUND WESTENREITER

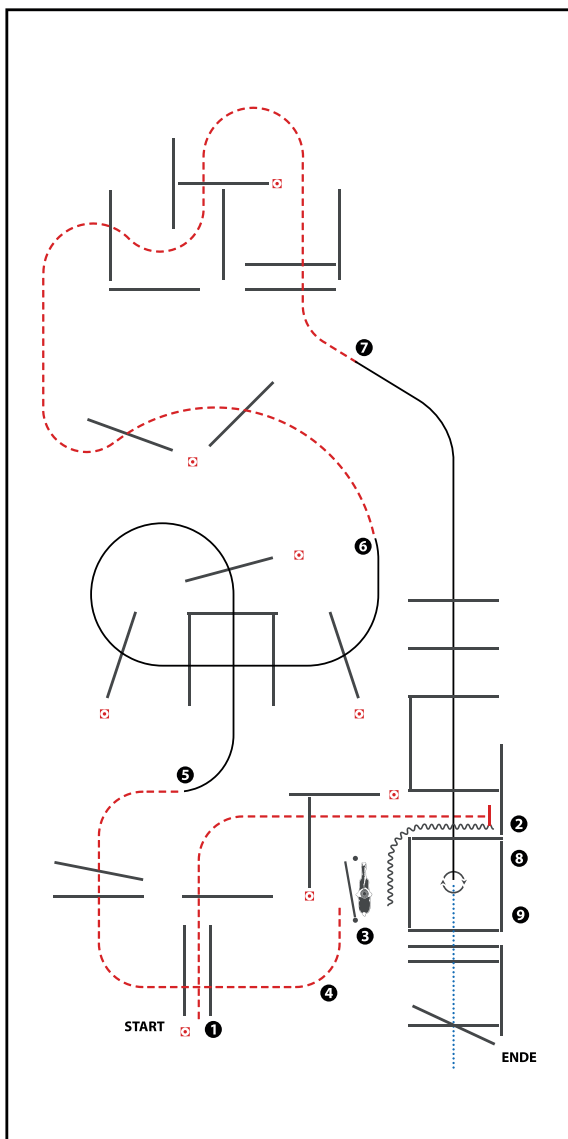

(Erhöhungen optional)

- 1) JOG OVER, JOG INTO CHUTE, STOP
- 2) BACK UP
- 3) GATE (LH)
- 4) JOG OVER
- 5) LOPE OVER (LL)
- 6) JOG OVER
- 7) LOPE OVER (RL)
- 8) LOPE INTO BOX, STOP,
360° TURN EITHER WAY (LEFT OR RIGHT)
- 9) WALK OUT, WALK OVER

WALK (SCHRITT)	
EXTENDED WALK	
JOG/TROT (TRAB)	
EXTENDED TROT	
LOPE (GALOPP)	
EXTENDED LOPE	
BACK UP (RÜCKWÄRTS)	
LEAD CHANGE (GALOPPWECHSEL)	
TURN (DREHUNG)	
	ERSTE
	WESTENREITER
	UNION
	WELDPFERDEBUND WESTENREITER

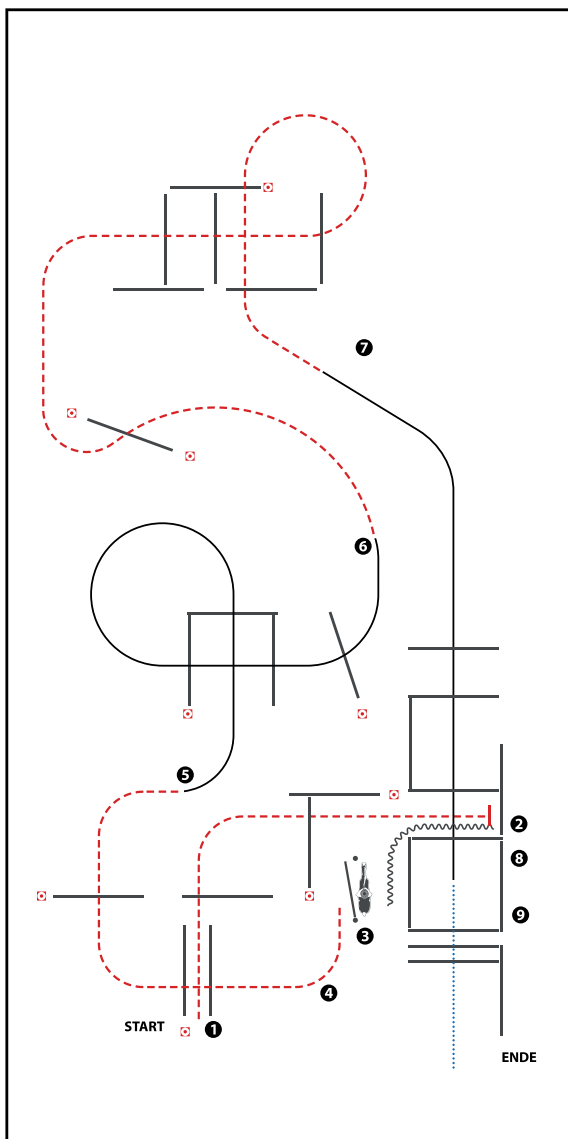

(Erhöhungen optional)

- 1) JOG OVER, JOG INTO CHUTE, STOP
- 2) BACK UP
- 3) GATE (LH)
- 4) JOG OVER
- 5) LOPE OVER (LL)
- 6) JOG OVER
- 7) LOPE OVER (RL)
- 8) LOPE INTO BOX, STOP
- 9) WALK OUT, WALK OVER

WALK (SCHRITT)	
EXTENDED WALK	
JOG/TROT (TRAB)	
EXTENDED TROT	
LOPE (GALOPP)	
EXTENDED LOPE	
BACK UP (RÜCKWÄRTS)	
LEAD CHANGE (GALOPPWECHSEL)	
TURN (DREHUNG)	
	ERSTE
	WESTENREITER
	UNION
	WELDPFERDEBUND WESTENREITER

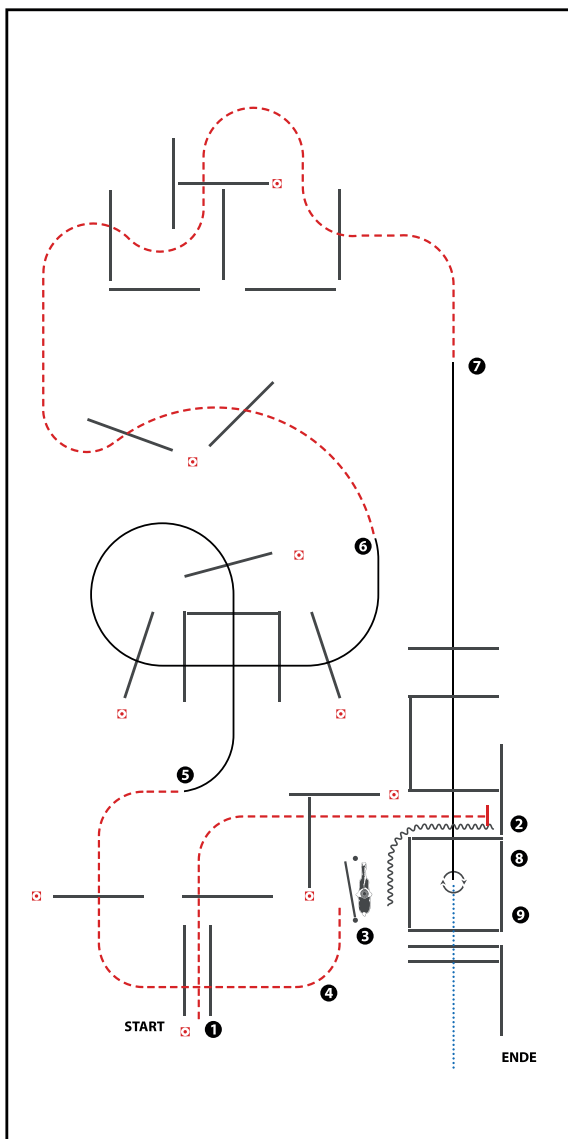

(Erhöhungen optional)

- 1) JOG OVER, JOG INTO CHUTE STOP
- 2) BACK UP
- 3) GATE (LH)
- 4) JOG OVER
- 5) LOPE OVER (LL)
- 6) JOG OVER
- 7) LOPE OVER (RL)
- 8) LOPE INTO BOX, STOP,
360° TURN EITHER WAY (LEFT OR RIGHT)
- 9) WALK OUT, WALK OVER

WALK (SCHRITT)	
EXTENDED WALK	
JOG/TROT (TRAB)	
EXTENDED TROT	
LOPE (GALOPP)	
EXTENDED LOPE	
BACK UP (RÜCKWÄRTS)	
LEAD CHANGE (GALOPPWECHSEL)	
TURN (DREHUNG)	
	ERSTE
	WESTENREITER
	UNION
	WESTENREITER

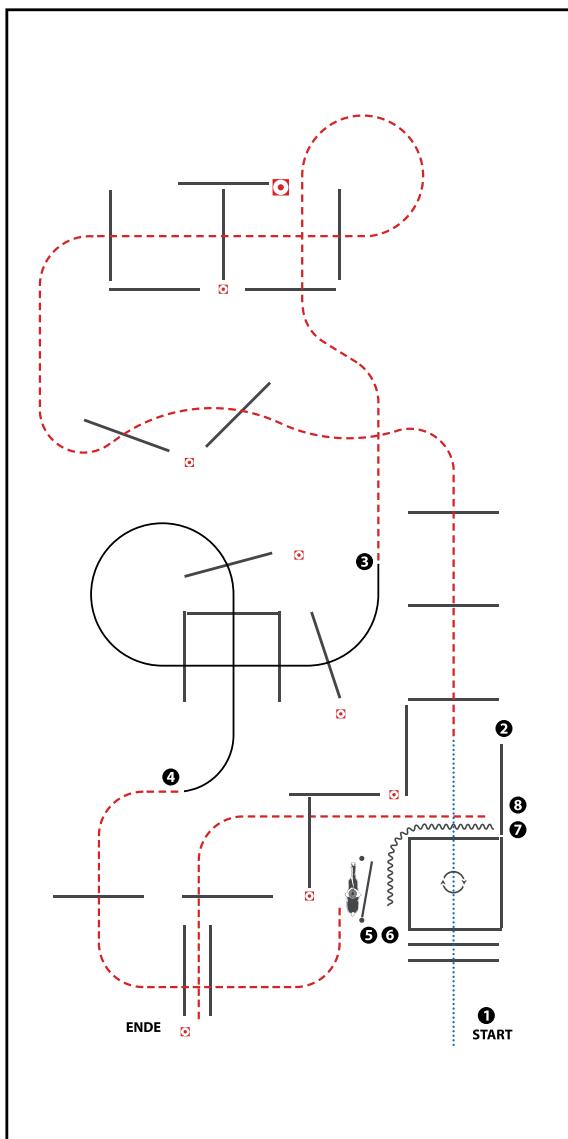

(Erhöhungen optional)

- 1) WALK OVER, WALK INTO BOX,
360° TURN EITHER WAY (LEFT OR RIGHT), WALK OUT
- 2) JOG OVER
- 3) LOPE OVER (RL)
- 4) JOG OVER
- 5) GATE (RH)
- 6) BACK UP
- 7) JOG OUT, JOG OVER

WALK (SCHRITT)	
EXTENDED WALK	
JOG/TROT (TRAB)	
EXTENDED TROT	
LOPE (GALOPP)	
EXTENDED LOPE	
BACK UP (RÜCKWÄRTS)	
LEAD CHANGE (GALOPPWECHSEL)	
TURN (DREHUNG)	
	ERSTE
	WEITERE
	UNION
	WIEDERHOLER

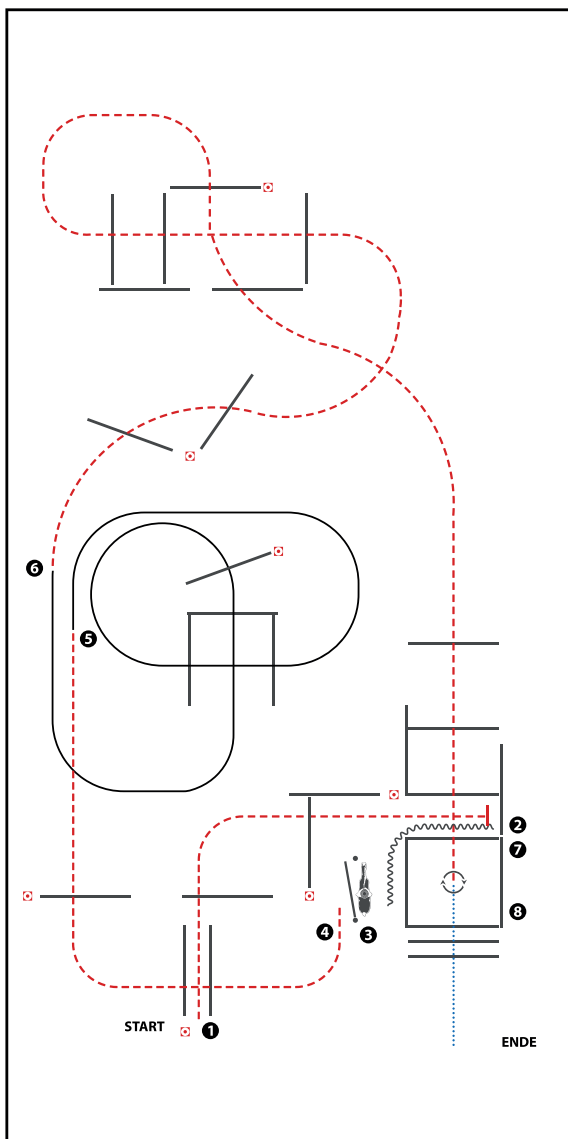

(Erhöhungen optional)

- 1) JOG OVER, JOG INTO CHUTE, STOP
- 2) BACK UP
- 3) GATE (LH)
- 4) JOG OVER
- 5) LOPE OVER (RL)
- 6) JOG OVER
- 7) JOG INTO BOX, STOP,
360° TURN EITHER WAY (LEFT OR RIGHT)
- 8) WALK OUT, WALK OVER

WALK (SCHRITT)	
EXTENDED WALK	
JOG/TROT (TRAB)	
EXTENDED TROT	
LOPE (GALOPP)	
EXTENDED LOPE	
BACK UP (RÜCKWÄRTS)	
LEAD CHANGE (GALOPPWECHSEL)	
TURN (DREHUNG)	
	ERSTE
	WESTENREITER
	UNION
	WELDPFERDEBUND

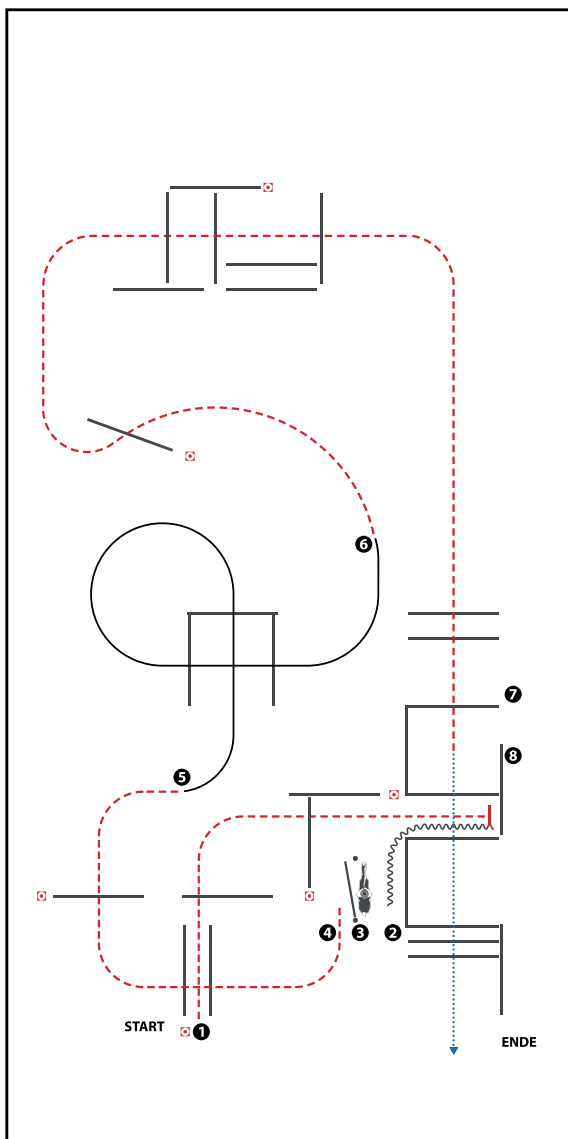

(Erhöhungen optional)

- 1) JOG OVER, JOG INTO CHUTE, STOP
- 2) BACK UP
- 3) GATE (LH)
- 4) JOG OVER
- 5) LOPE OVER (LL)
- 6) JOG OVER
- 7) JOG INTO BOX, STOP
- 8) WALK OUT, WALK OVER

WALK (SCHRITT)	
EXTENDED WALK	
JOG/TROT (TRAB)	
EXTENDED TROT	
LOPE (GALOPP)	
EXTENDED LOPE	
BACK UP (RÜCKWÄRTS)	
LEAD CHANGE (GALOPPWECHSEL)	
TURN (DREHUNG)	
	ERSTE
	WESTERWEITER
	UNION
	WIEDERWECHSEL

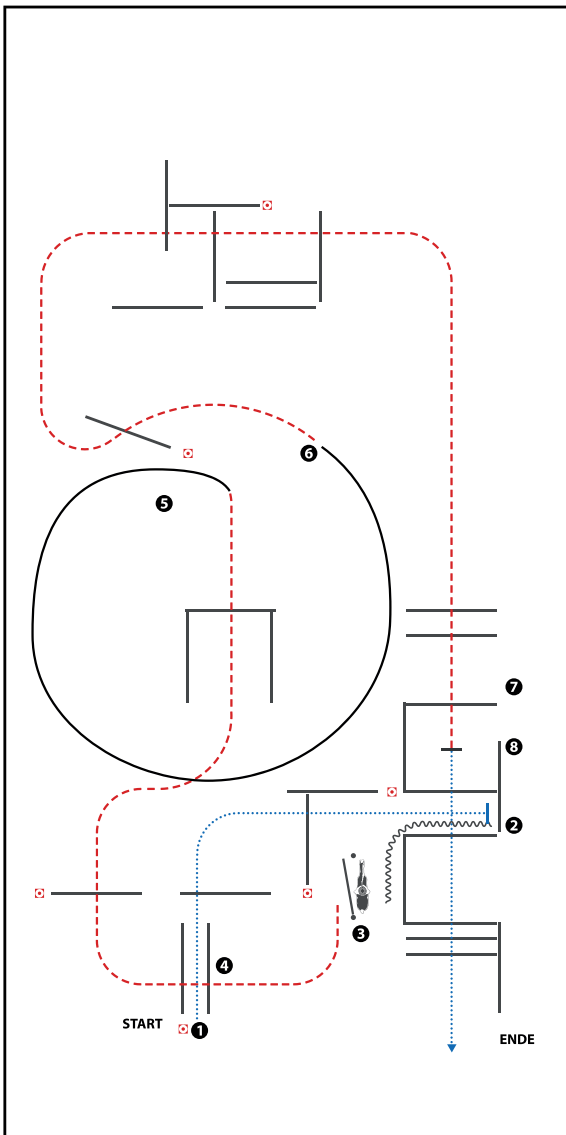

- 1) WALK OVER, WALK INTO CHUTE, STOP
- 2) BACK UP
- 3) GATE (LH), JOG OUT
- 4) JOG OVER
- 5) LOPE (LL)
- 6) JOG OVER
- 7) JOG INTO BOX, STOP
- 8) WALK OUT, WALK OVER

WALK (SCHRITT)	
EXTENDED WALK	
JOG/TROT (TRAB)	
EXTENDED TROT	
LOPE (GALOPP)	
EXTENDED LOPE	
BACK UP (RÜCKWÄRTS)	
LEAD CHANGE (GALOPPWECHSEL)	
TURN (DREHUNG)	
	ERSTE
	WESTENREITER
	UNION
	WELDPFERDEBUND WESTENREITER

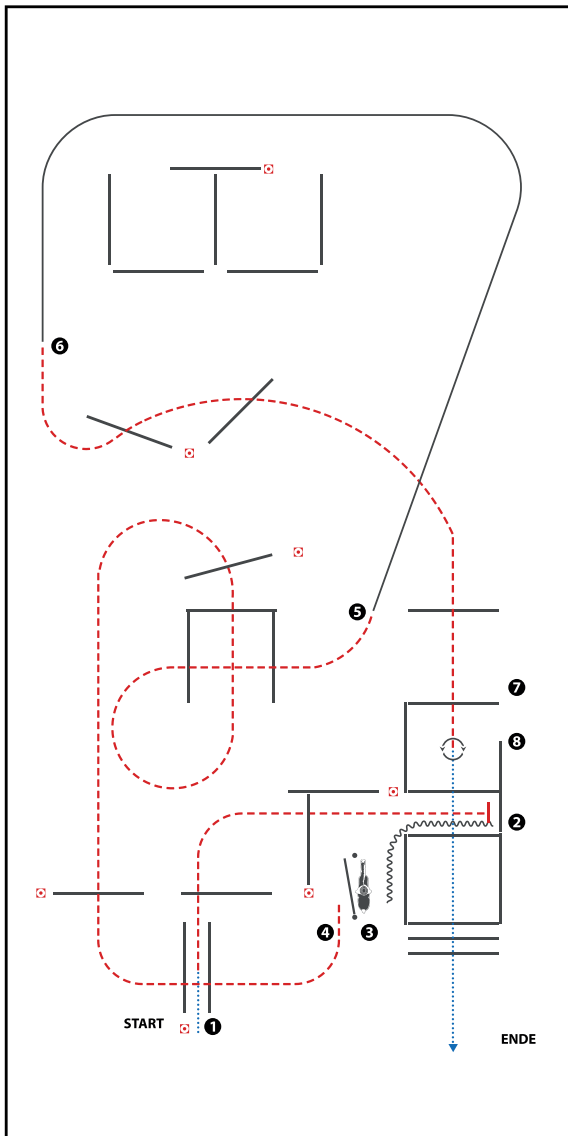

- 1) WALK, JOG OVER, JOG INTO CHUTE, STOP
- 2) BACK UP
- 3) GATE (LH)
- 4) JOG OVER
- 5) LOPE (LL)
- 6) JOG OVER
- 7) JOG INTO BOX, STOP,
360° TURN EITHER WAY (LEFT OR RIGHT)
- 8) WALK OUT, WALK OVER

WALK (SCHRITT)	
EXTENDED WALK	
JOG/TROT (TRAB)	
EXTENDED TROT	
LOPE (GALOPP)	
EXTENDED LOPE	
BACK UP (RÜCKWÄRTS)	
LEAD CHANGE (GALOPPWECHSEL)	
TURN (DREHUNG)	
	ERSTE WESTENREITER UNION WESTENREITER

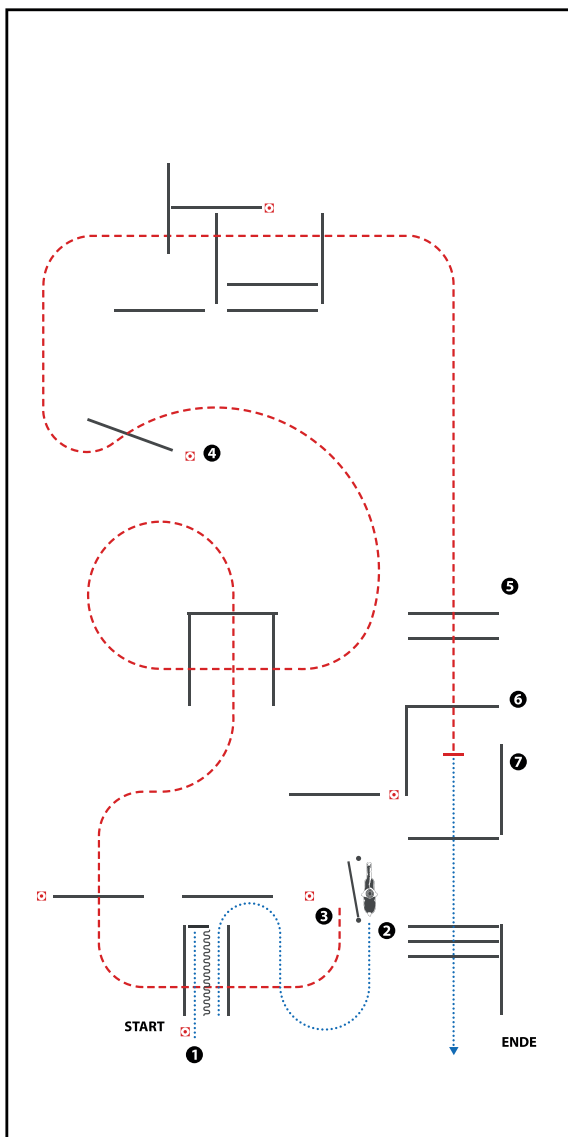

(Tor ist optional)

- 1) WALK INTO CHUTE, STOP, BACK UP, WALK OUT
(im Schritt in die Gasse, Anhalten, Rückwärts, Schritt)
- 2) GATE (LH) (Tor -linke Hand)
- 3) JOG OVER 6 POLES (6 Trabstangen)
- 4) JOG OVER 4 POLES (4 Trabstangen)
- 5) JOG OVER 2 POLES (2 Trabstangen)
- 6) JOG OVER, JOG INTO BOX, STOP (Trabstange,
Trab in die Box, Stop)
- 7) WALK OUT, WALK OVER (im Schritt raus, Schrittstange)

WALK (SCHRITT)
EXTENDED WALK
JOG/TROT (TRAB)	-----
EXTENDED TROT	-----
LOPE (GALOPP)	=====
EXTENDED LOPE	=====
BACK UP (RÜCKWÄRTS)	~~~~~
LEAD CHANGE (GALOPPWECHSEL)	=====
TURN (DREHUNG)	⤵
ERSTE	=====
WESTENREITER	=====
UNION	=====
WESTENREITER	=====

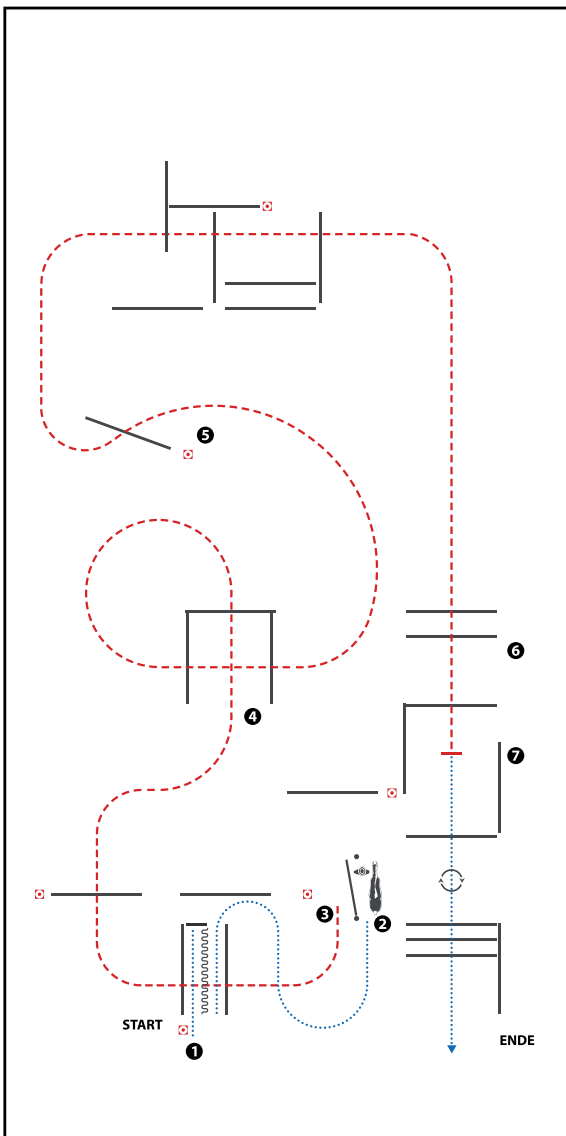

- 1) WALK INTO CHUTE, STOP, BACK UP, WALK OUT
- 2) GATE (LH)
- 3) JOG OVER 6 POLES
- 4) JOG OVER 4 POLES
- 5) JOG OVER 2 POLES
- 6) JOG OVER, JOG INTO BOX, STOP
- 7) WALK OUT, 360° TURN RIGHT, WALK OVER

WALK (SCHRITT)	
EXTENDED WALK	
JOG/TROT (TRAB)	
EXTENDED TROT	
EXTENDED LOPE	
BACK UP (RÜCKWÄRTS)	
LEAD CHANGE (GALOPPWECHSEL)	
TURN (DREHUNG)	
ERSTE	
WESTENREITER	
UNION	
WIRTSCHAFTSUNIVERSITÄT SIEGEN	

Trail Set 6 mit Brücke

Pattern 1-8

Arenagröße mind. 25 x 50 m

Für TH-Pattern gelten folgende Abstände und Maße:

WALK / WALK OVER	Abstand 40 - 60 cm • Erhöhung max. 30 cm. Bei Erhöhung sollte der Mindestabstand 55 cm betragen.
JOG / JOG OVER	Abstand 90 - 105 cm • Erhöhung max. 20 cm.
EXTENDED JOG	Abstand 105 - 125 cm.
LOPE / LOPE OVER	Abstand 180 - 210 cm • Erhöhung max. 20 cm.
EXTENDED LOPE	Abstand 210 - 225 cm.
BACK UP	Abstandmind. 100 cm, Erhöhung max. 30 cm.
SIDEPASS	Abstand in einer Gasse mind. 200 cm (ganzes Pferd), mind. 60 cm (1 Beinpaar zwischen zwei Stangen), Erhöhung max. 30 cm.
SERPENTIN WALK	Abstand mind. 200 cm
SERPENTIN JOG	Abstand mind. 250 cm
GATE	Breite mind. 90 cm, Länge 250 cm,
BRIDGE	Breite mind. 150 cm, Länge 250 cm,
BRIDGE WITH RAILING	Breite mind. 150 cm, Länge 250 cm,
BOX	Abstand 180 - 210 cm
JUMP	Erhöhung max. 45 cm

Zwischen den Hindernissen sollte eine:

Trabstrecke von mind. 10,00 m

Galoppstrecke von mind. 20,00 m

Volten sollten für Reiter der LK 5 und 4 nicht weniger als 12,00 m Durchmesser,
für LK 1 bis 3 nicht weniger als 10,00 m betragen

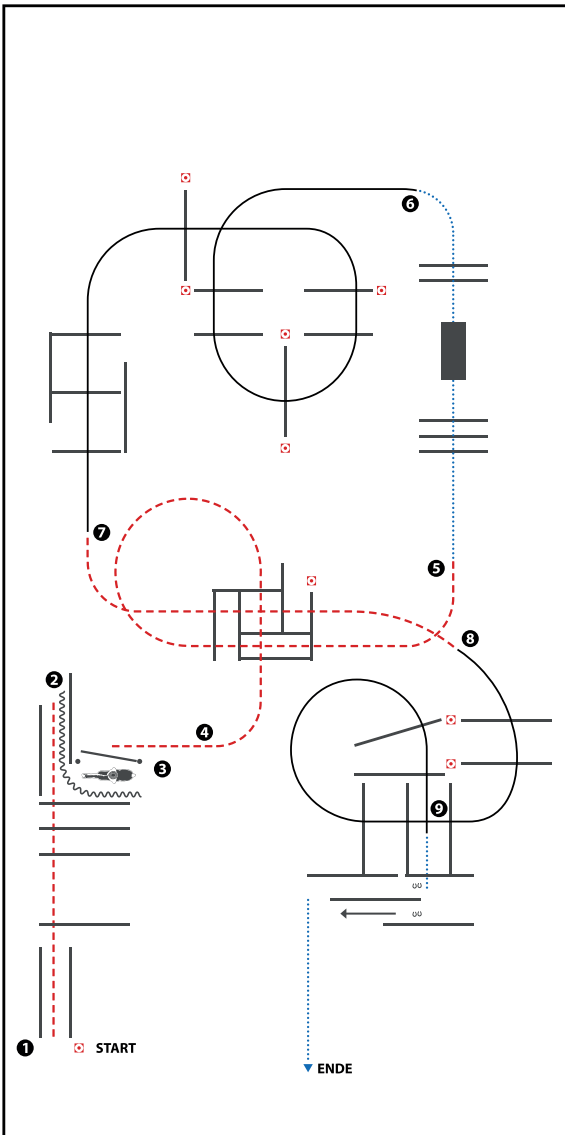

(Erhöhungen optional)

- 1) JOG OVER, JOG INTO CHUTE, STOP
- 2) BACK UP
- 3) GATE RH
- 4) JOG OVER
- 5) STOP OR BREAK TO WALK, WALK OVER, BRIDGE, WALK OVER
- 6) LOPE OVER (LL)
- 7) JOG OVER
- 8) LOPE OVER (RL)
- 9) LOPE INTO CHUTE, STOP OR BREAK TO WALK, WALK OVER, SIDEPASS RIGHT

WALK (SCHRITT)
EXTENDED WALK
JOG/TROT (TRAB)	-----
EXTENDED TROT	-----
LOPE (GALOPP)	=====
EXTENDED LOPE	=====
BACK UP (RÜCKWÄRTS)	~~~~~
LEAD CHANGE (GALOPPWECHSEL)	=====
TURN (DREHUNG)	
	ERSTE
	WESTENREITER
	UNION
	WELDPFERDEBUND WESTERWALD

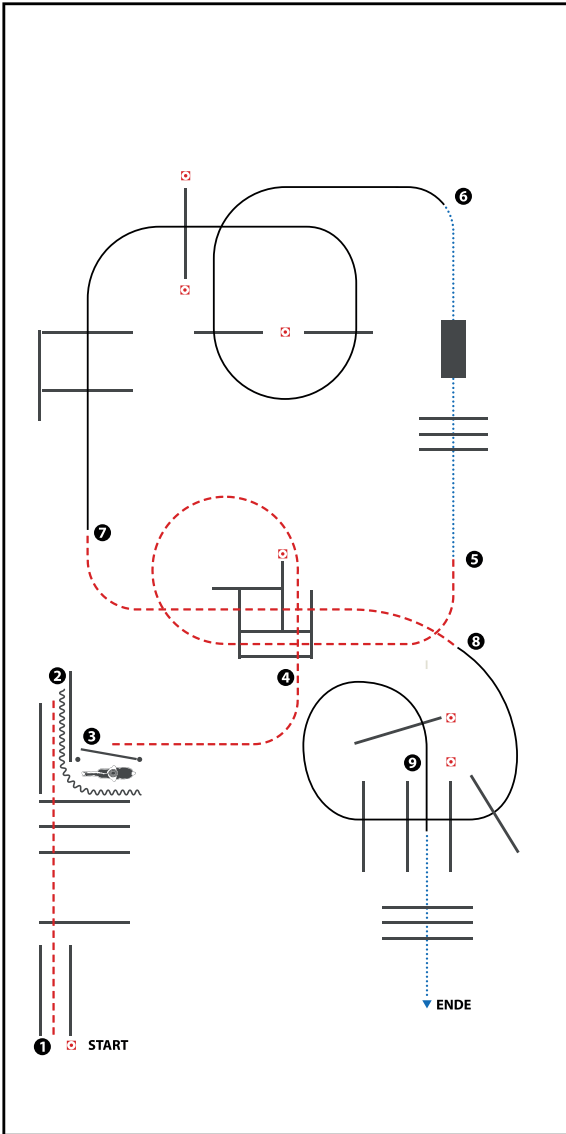

(Erhöhungen optional)

- 1) JOG OVER, JOG INTO CHUTE, STOP
- 2) BACK UP
- 3) GATE RH, JOG
- 4) JOG OVER
- 5) STOP OR BREAK TO WALK, WALK OVER, BRIDGE
- 6) LOPE OVER (LL)
- 7) JOG OVER
- 8) LOPE OVER (RL)
- 9) LOPE INTO CHUTE, STOP OR BREAK TO WALK, WALK OVER

WALK (SCHRITT)	
EXTENDED WALK	
JOG/TROT (TRAB)	
EXTENDED TROT	
LOPE (GALOPP)	
EXTENDED LOPE	
BACK UP (RÜCKWÄRTS)	
LEAD CHANGE (GALOPPWECHSEL)	
TURN (DREHUNG)	
ERSTE	
WESTENREITER	
UNION	
WELDPFERDEBUND WELDPFERTE	

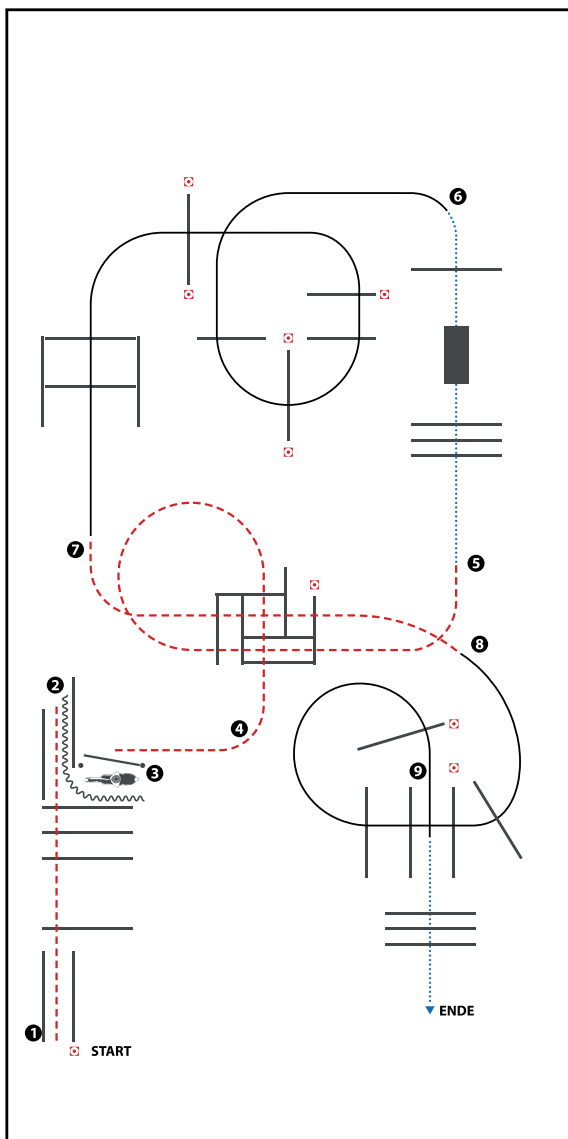

(Erhöhungen optional)

- 1) JOG OVER, JOG INTO CHUTE, STOP
- 2) BACK UP
- 3) GATE RH
- 4) JOG OVER
- 5) STOP OR BREAK TO WALK, WALK OVER, BRIDGE, WALK OVER
- 6) LOPE OVER (LL)
- 7) JOG OVER
- 8) LOPE OVER (RL)
- 9) LOPE INTO CHUTE, STOP OR BREAK TO WALK, WALK OVER

WALK (SCHRITT)	
EXTENDED WALK	
JOG/TROT (TRAB)	
EXTENDED TROT	
LOPE (GALOPP)	
EXTENDED LOPE	
BACK UP (RÜCKWÄRTS)	
LEAD CHANGE (GALOPPWECHSEL)	
TURN (DREHUNG)	
ERSTE	
WESTENREITER	
UNION	
WIRTSCHAFTSUNIVERSITÄT SIEGEN	

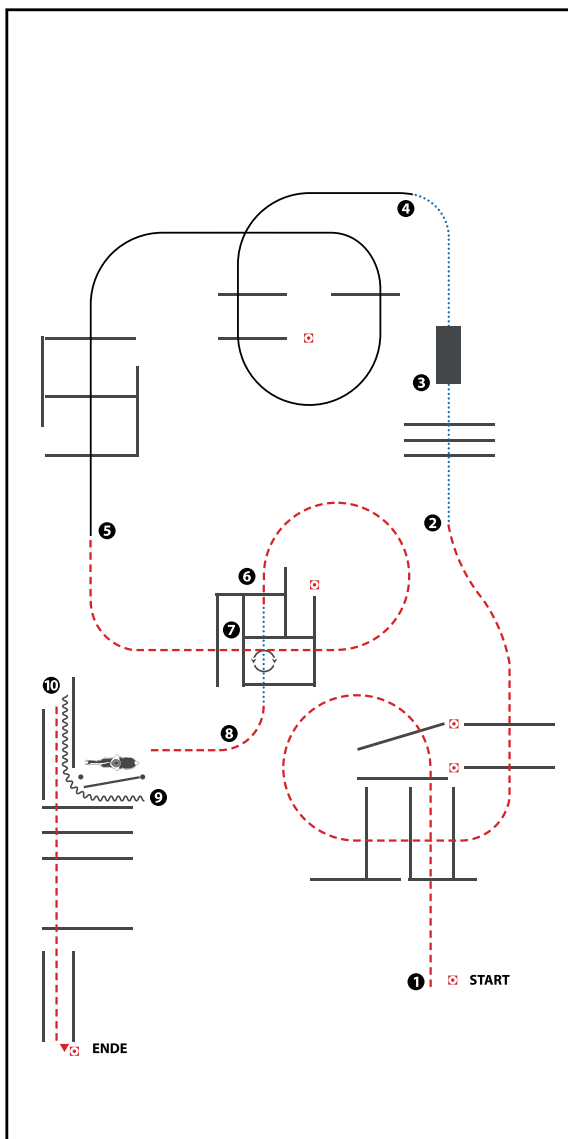

(Erhöhungen optional)

- 1) JOG OVER
- 2) WALK OVER
- 3) BRIDGE
- 4) LOPE OVER (LL)
- 5) JOG OVER
- 6) JOG INTO THE 1. BOX, STOP OR BREAK TO WALK, WALK INTO THE 2. BOX, 360° TURN EITHER WAY (LEFT OR RIGHT), WALK OUT
- 7) JOG, GATE LH
- 8) BACK UP
- 9) JOG OVER, JOG OUT

WALK (SCHRITT)
EXTENDED WALK	-----
JOG/TROT (TRAB)	- - - - -
EXTENDED TROT
LOPE (GALOPP)	=====
EXTENDED LOPE	-----
BACK UP (RÜCKWÄRTS)	~~~~~
LEAD CHANGE (GALOPPWECHSEL)	=====
TURN (DREHUNG)	
ERSTE	
WESTENREITER	
UNION	
WESTENREITER	
WESTENREITER	

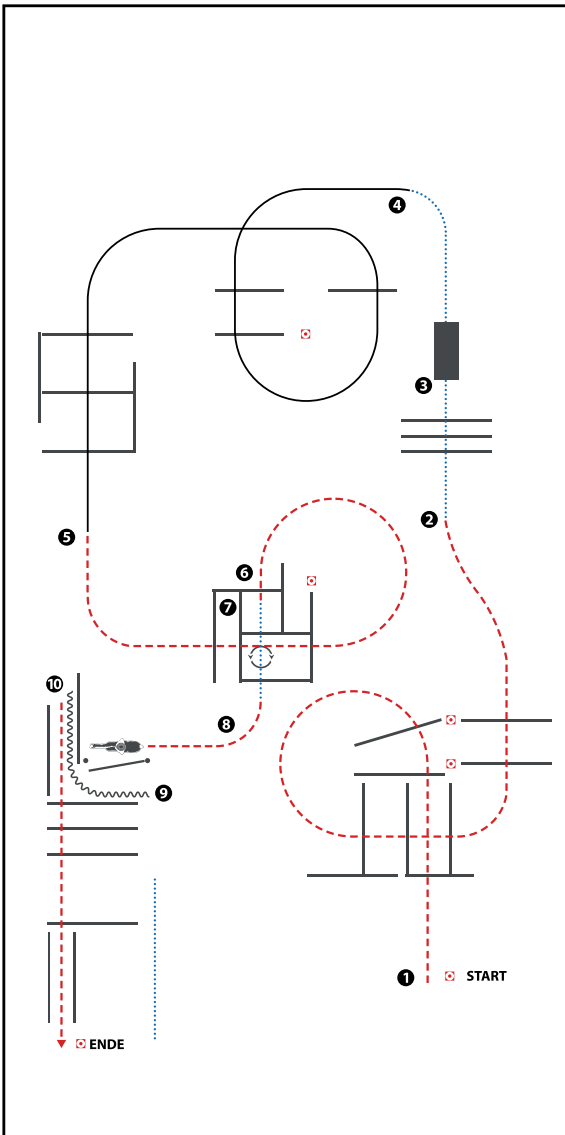

(Erhöhungen optional)

- 1) JOG OVER
- 2) WALK OVER
- 3) BRIDGE
- 4) LOPE OVER (LL)
- 5) JOG OVER
- 6) JOG INTO THE 1. BOX, STOP OR BREAK TO WALK, WALK INTO THE 2. BOX, 360° TURN EITHER WAY (LEFT OR RIGHT), WALK OUT
- 7) JOG, GATE LH
- 8) BACK UP
- 9) JOG OVER, JOG OUT

WALK (SCHRITT)	
EXTENDED WALK	
JOG/TROT (TRAB)	
EXTENDED TROT	
LOPE (GALOPP)	
EXTENDED LOPE	
BACK UP (RÜCKWÄRTS)	
LEAD CHANGE (GALOPPWECHSEL)	
TURN (DREHUNG)	
ERSTE	
WEITERE	
UNION	
WIEDERHOLER	

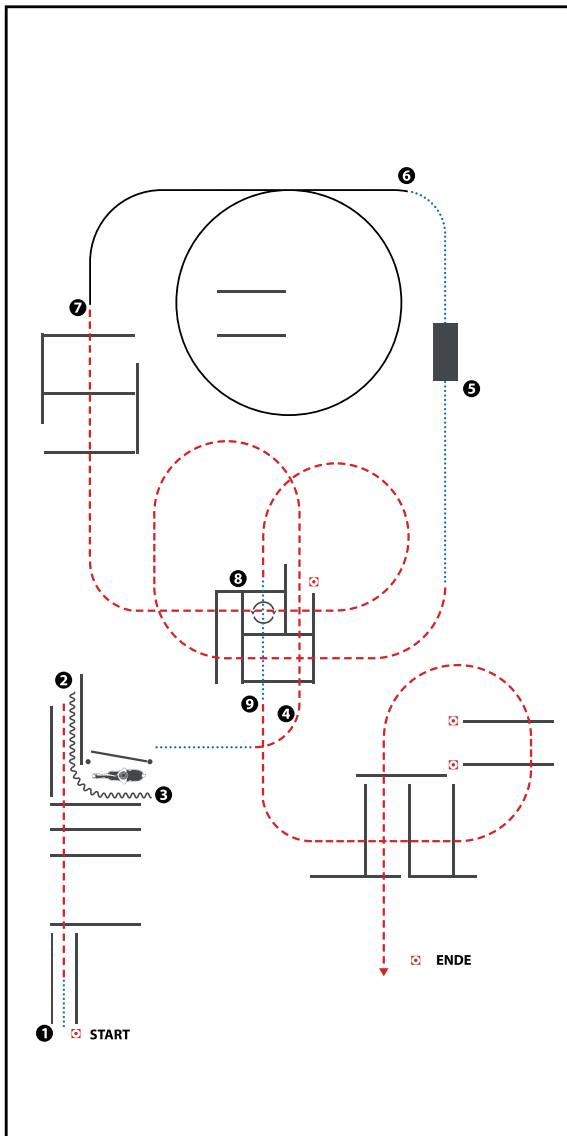

- 1) WALK, JOG OVER, JOG INTO CHUTE, STOP
- 2) BACK UP
- 3) GATE RH, WALK
- 4) JOG OVER
- 5) WALK OVER BRIDGE
- 6) LOPE (LL)
- 7) JOG OVER
- 8) WALK INTO 1. BOX,
360° TURN EITHER WAY (LEFT OR RIGHT), WALK OUT
- 9) JOG OVER

WALK (SCHRITT)	
EXTENDED WALK	
JOG/TROT (TRAB)	
EXTENDED TROT	
EXTENDED LOPE	
BACK UP (RÜCKWÄRTS)	
LEAD CHANGE (GALOPPWECHSEL)	
TURN (DREHUNG)	
ERSTE	
WESTENREITER	
UNION	
WESTENREITER	

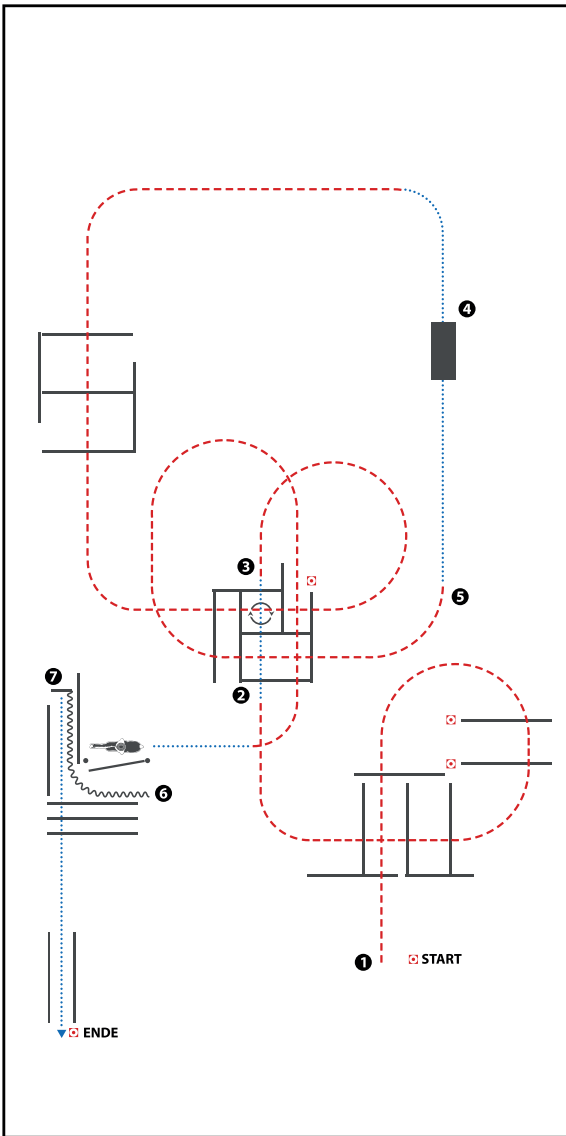

(Tor ist optional)

- 1) JOG OVER (Trabstangen)
- 2) WALK INTO BOX, 360° TURN RIGHT, WALK OUT
(im Schritt in die Box, 360° Wendung rechts,
im Schritt aus der Box)
- 3) JOG OVER (Trabstangen)
- 4) WALK OVER BRIDGE (im Schritt über die Brücke)
- 5) JOG OVER (Trabstangen)
- 6) GATE LH (Tor, linke Hand)
- 7) BACK UP (Rückwärts)
- 8) WALK OVER (Schrittstangen)

WALK (SCHRITT)
EXTENDED WALK	-----
JOG/TROT (TRAB)	- - - - -
EXTENDED TROT	-----
LOPE (GALOPP)	=====
EXTENDED LOPE	=====
BACK UP (RÜCKWÄRTS)	~~~~~
LEAD CHANGE (GALOPPWECHSEL)	=====
TURN (DREHUNG)	↻
ERSTE	=====
WESTENREITER	=====
UNION	=====
WESTENREITER	=====

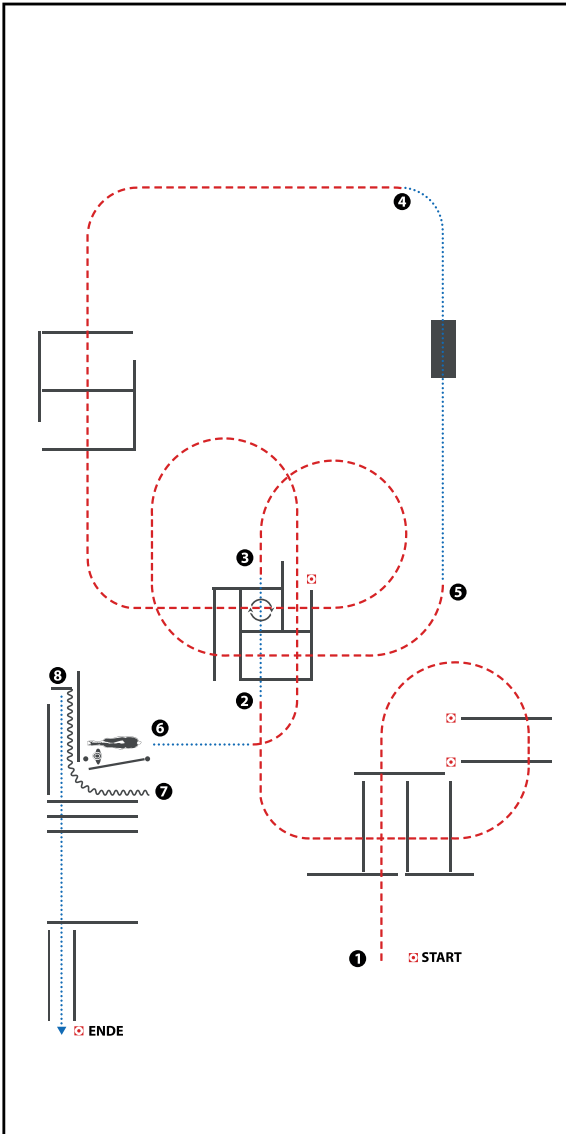

- 1) JOG OVER
- 2) WALK INTO BOX, 360° TURN RIGHT, WALK OUT
- 3) JOG OVER
- 4) WALK OVER BRIDGE
- 5) JOG OVER
- 6) GATE LH
- 7) BACK UP
- 8) WALK OVER

WALK (SCHRITT)	
EXTENDED WALK	
JOG/TROT (TRAB)	
EXTENDED TROT	
LOPE (GALOPP)	
EXTENDED LOPE	
BACK UP (RÜCKWÄRTS)	
LEAD CHANGE (GALOPPWECHSEL)	
TURN (DREHUNG)	
ERSTE	
WESTENREITER	
UNION	
WELDPFERDEBUND WELDPFERTEUR	

Trail Set 7 mit Brücke

Pattern 1-8

Arenagröße mind. 25 x 50 m

Für TH-Pattern gelten folgende Abstände und Maße:

WALK / WALK OVER	Abstand 40 - 60 cm • Erhöhung max. 30 cm. Bei Erhöhung sollte der Mindestabstand 55 cm betragen.
JOG / JOG OVER	Abstand 90 - 105 cm • Erhöhung max. 20 cm.
EXTENDED JOG	Abstand 105 - 125 cm.
LOPE / LOPE OVER	Abstand 180 - 210 cm • Erhöhung max. 20 cm.
EXTENDED LOPE	Abstand 210 - 225 cm.
BACK UP	Abstandmind. 100 cm, Erhöhung max. 30 cm.
SIDEPASS	Abstand in einer Gasse mind. 200 cm (ganzes Pferd), mind. 60 cm (1 Beinpaar zwischen zwei Stangen), Erhöhung max. 30 cm.
SERPENTIN WALK	Abstand mind. 200 cm
SERPENTIN JOG	Abstand mind. 250 cm
GATE	Breite mind. 90 cm, Länge 250 cm,
BRIDGE	Breite mind. 150 cm, Länge 250 cm,
BRIDGE WITH RAILING	Breite mind. 150 cm, Länge 250 cm,
BOX	Abstand 180 - 210 cm
JUMP	Erhöhung max. 45 cm

Zwischen den Hindernissen sollte eine:

Trabstrecke von mind. 10,00 m

Galoppstrecke von mind. 20,00 m

Volten sollten für Reiter der LK 5 und 4 nicht weniger als 12,00 m Durchmesser,
für LK 1 bis 3 nicht weniger als 10,00 m betragen

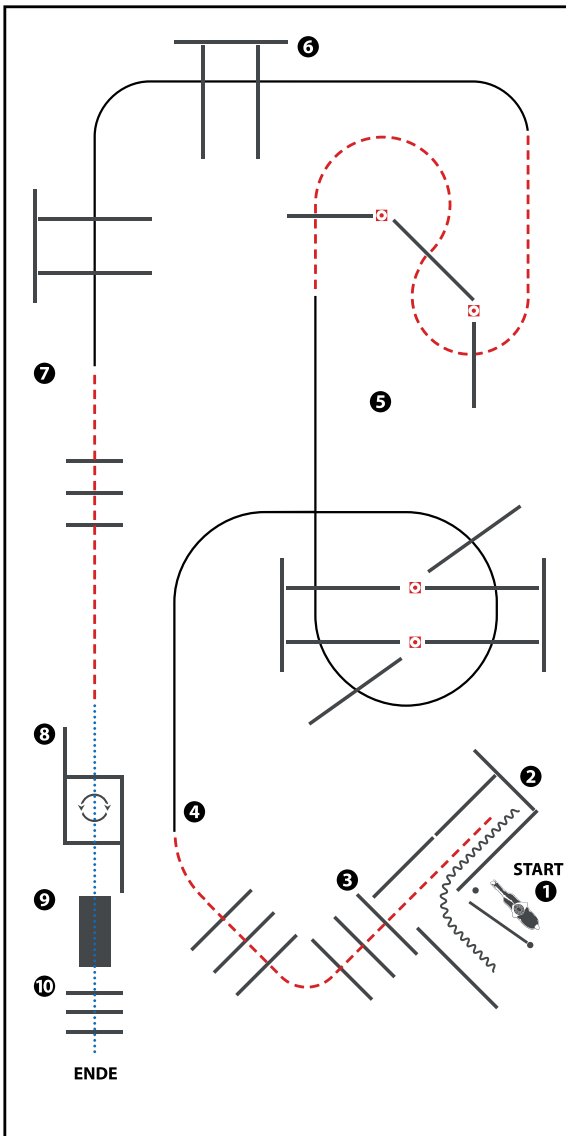

(Erhöhungen optional)

- 1) GATE LH
- 2) BACK UP, JOG OUT
- 3) JOG OVER
- 4) LOPE OVER (RL)
- 5) JOG OVER
- 6) LOPE OVER (LL)
- 7) JOG OVER
- 8) WALK INTO BOX, 360° TURN EITHER WAY (LEFT OR RIGHT), WALK OUT
- 9) BRIDGE
- 10) WALK OVER

WALK (SCHRITT)
EXTENDED WALK
JOG/TROT (TRAB)	-----
EXTENDED TROT	-----
LOPE (GALOPP)	=====
EXTENDED LOPE	=====
BACK UP (RÜCKWÄRTS)	~~~~~
LEAD CHANGE (GALOPPWECHSEL)	=====
TURN (DREHUNG)	
	ERSTE
	WESTENREITER
	UNION
	WELDPFERDEBUND WELDPFERTEUR

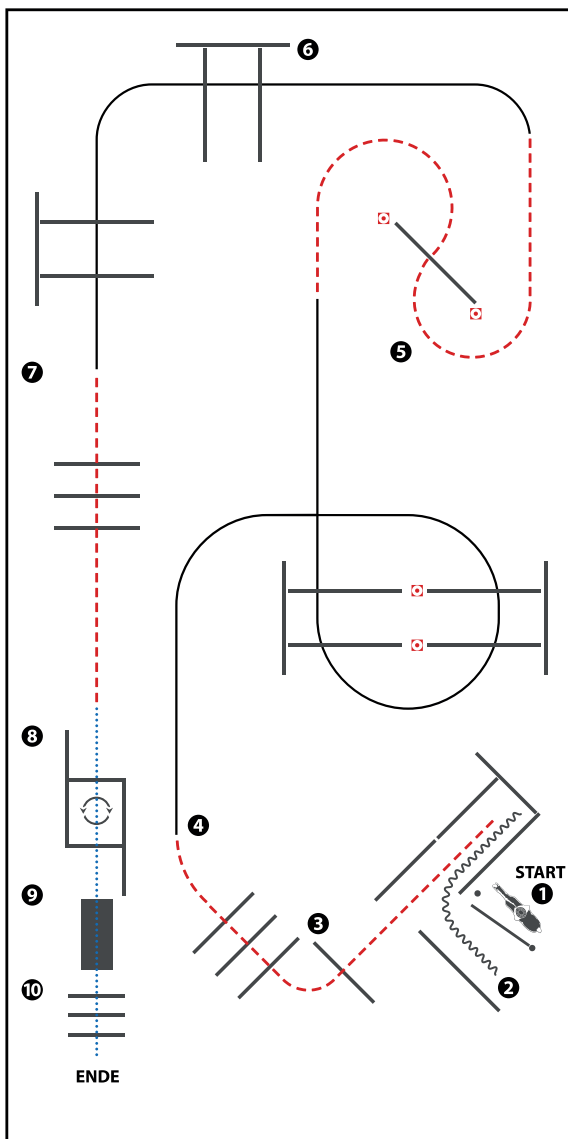

(Erhöhungen optional)

- 1) GATE LH
- 2) BACK UP, JOG OUT
- 3) JOG OVER
- 4) LOPE OVER (RL)
- 5) JOG OVER
- 6) LOPE OVER (LL)
- 7) JOG OVER
- 8) WALK INTO BOX, 360° TURN EITHER WAY (LEFT OR RIGHT), WALK OUT
- 9) BRIDGE
- 10) WALK OVER

WALK (SCHRITT)	
EXTENDED WALK	
JOG/TROT (TRAB)	
EXTENDED TROT	
LOPE (GALOPP)	
EXTENDED LOPE	
BACK UP (RÜCKWÄRTS)	
LEAD CHANGE (GALOPPWECHSEL)	
TURN (DREHUNG)	
	ERSTE
	WESTENREITER
	UNION
	WELDPFERDEBUND WESTENREITER

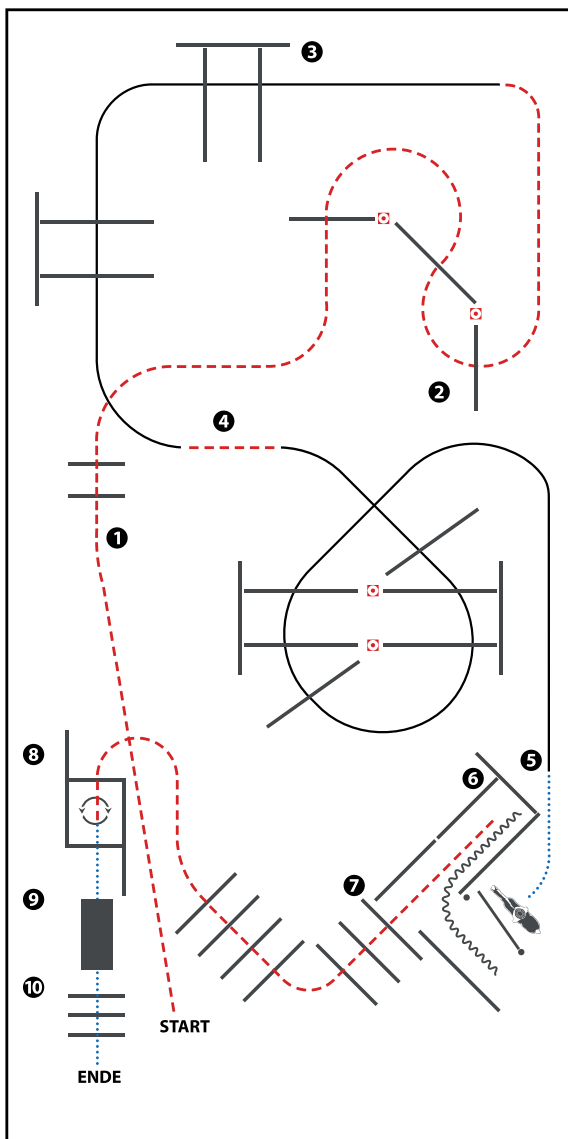

(Erhöhungen optional)

- 1) JOG OVER
- 2) JOG OVER
- 3) LOPE OVER (LL)
- 4) JOG, LOPE OVER (RL)
- 5) WALK, GATE
- 6) BACK UP, JOG OUT
- 7) JOG OVER
- 8) JOG INTO BOX, 360° TURN EITHER WAY (LEFT OR RIGHT), WALK OUT
- 9) BRIDGE
- 10) WALK OVER

WALK (SCHRITT)	
EXTENDED WALK	
JOG/TROT (TRAB)	
EXTENDED TROT	
LOPE (GALOPP)	
EXTENDED LOPE	
BACK UP (RÜCKWÄRTS)	
LEAD CHANGE (GALOPPWECHSEL)	
TURN (DREHUNG)	
	ERSTE
	WESTENREITER
	UNION
	WELDPFERDEBUND WESTENREITER

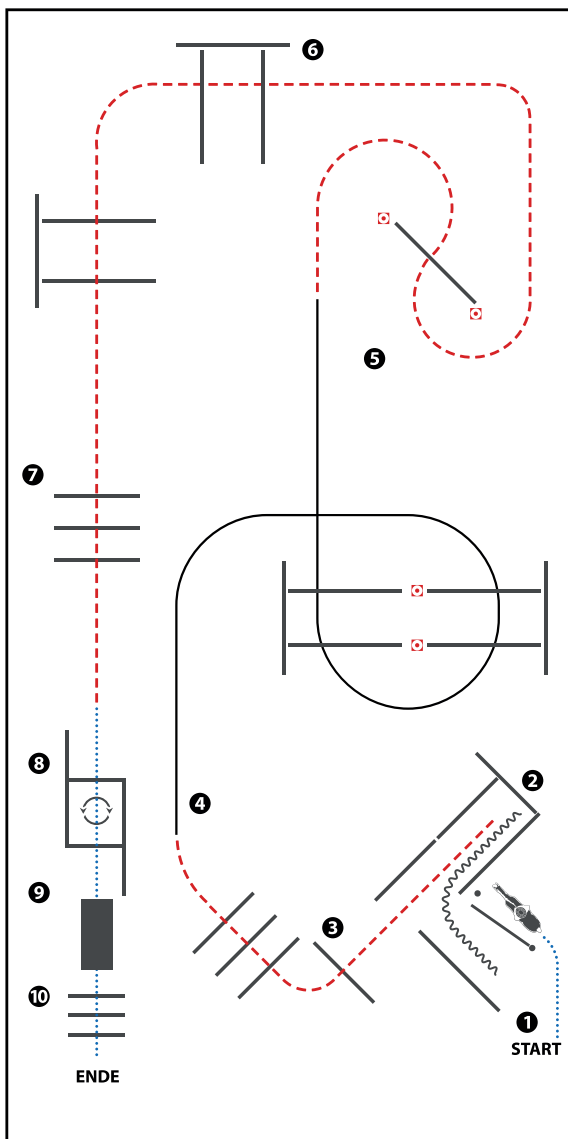

(Erhöhungen optional)

- 1) GATE LH
- 2) BACK UP, JOG OUT
- 3) JOG OVER
- 4) LOPE OVER (RL)
- 5) JOG OVER
- 6) JOG OVER
- 7) JOG OVER
- 8) WALK INTO BOX, 360° TURN EITHER WAY (LEFT OR RIGHT), WALK OUT
- 9) BRIDGE
- 10) WALK OVER

WALK (SCHRITT)	
EXTENDED WALK	
JOG/TROT (TRAB)	
EXTENDED TROT	
LOPE (GALOPP)	
EXTENDED LOPE	
BACK UP (RÜCKWÄRTS)	
LEAD CHANGE (GALOPPWECHSEL)	
TURN (DREHUNG)	
	ERSTE
	WESTREITER
	UNION
	WIRTSCHAFTSCHAFT

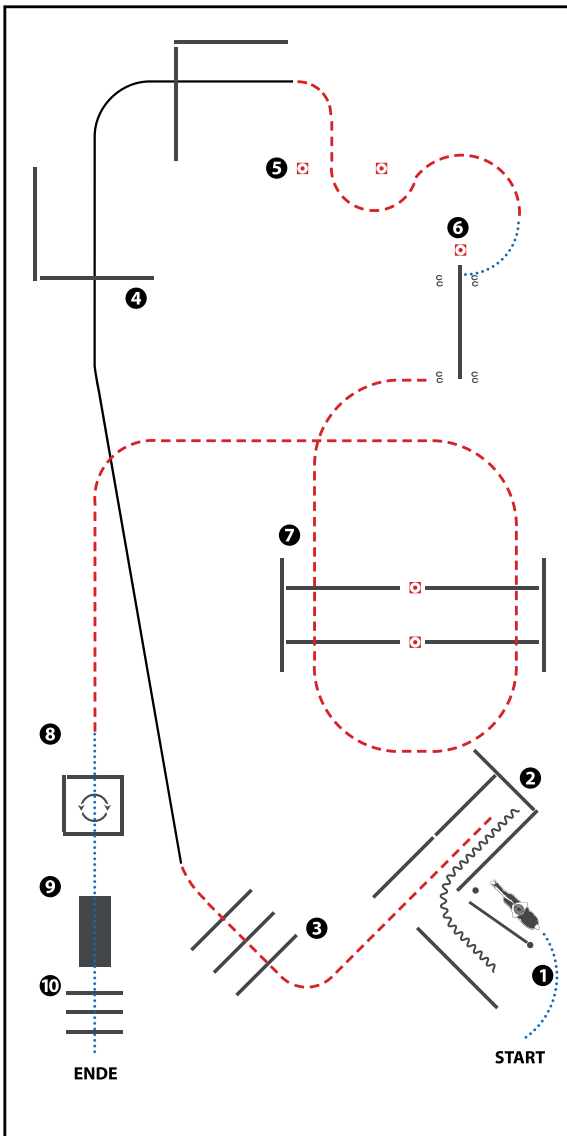

(Erhöhungen optional)

- 1) WALK, GATE
- 2) BACK UP, JOG OUT
- 3) JOG OVER
- 4) LOPE OVER (RL)
- 5) JOG THRU MARKER
- 6) WALK, SIDEPASS LEFT
- 7) JOG OVER
- 8) WALK INTO BOX, 360° TURN EITHER WAY (LEFT OR RIGHT), WALK OUT
- 9) BRIDGE
- 10) WALK OVER

WALK (SCHRITT)	
EXTENDED WALK	
JOG/TROT (TRAB)	
EXTENDED TROT	
LOPE (GALOPP)	
EXTENDED LOPE	
BACK UP (RÜCKWÄRTS)	
LEAD CHANGE (GALOPPWECHSEL)	
TURN (DREHUNG)	
ERSTE	
WESTENREITER	
UNION	
WELDPFERDEBUND DEUTSCHLAND	

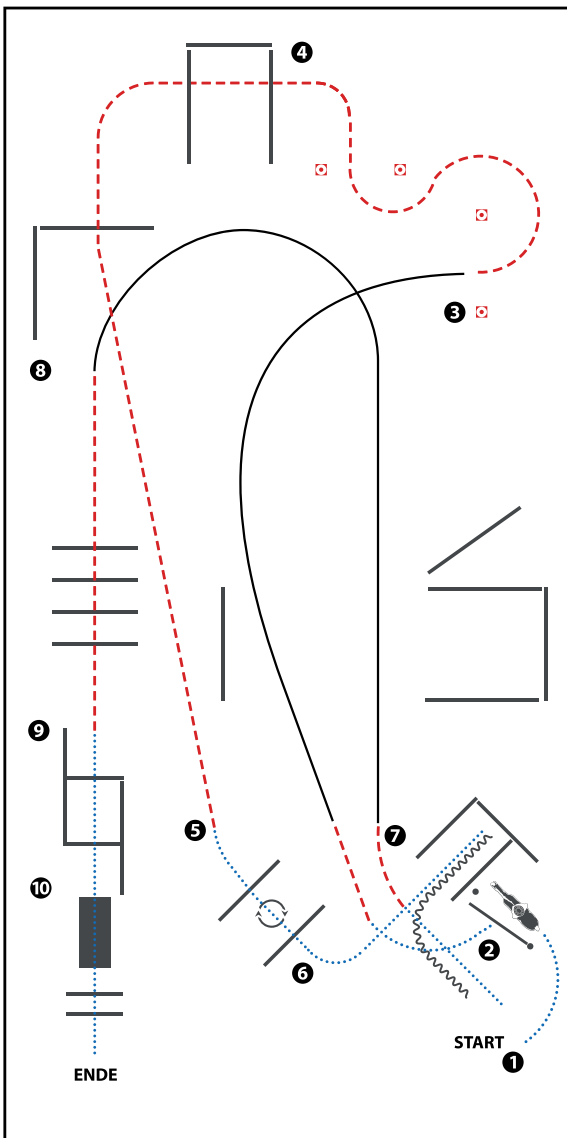

- 1) WALK, GATE, WALK
- 2) WALK, JOG, LOPE (RL)
- 3) JOG THRU MARKER
- 4) JOG OVER
- 5) WALK IN BOX, 360° TURN, WALK OUT
- 6) WALK INTO CHUTE, BACK UP
- 7) WALK, JOG, LOPE (LL)
- 8) JOG OVER
- 9) WALK OVER BRIDGE
- 10) WALK OVER

WALK (SCHRITT)	
EXTENDED WALK	
JOG/TROT (TRAB)	
EXTENDED TROT	
LOPE (GALOPP)	
EXTENDED LOPE	
BACK UP (RÜCKWÄRTS)	
LEAD CHANGE (GALOPPWECHSEL)	
TURN (DREHUNG)	
	ERSTE
	WESTENREITER
	UNION
	WIEDERWIEDERHOLUNG

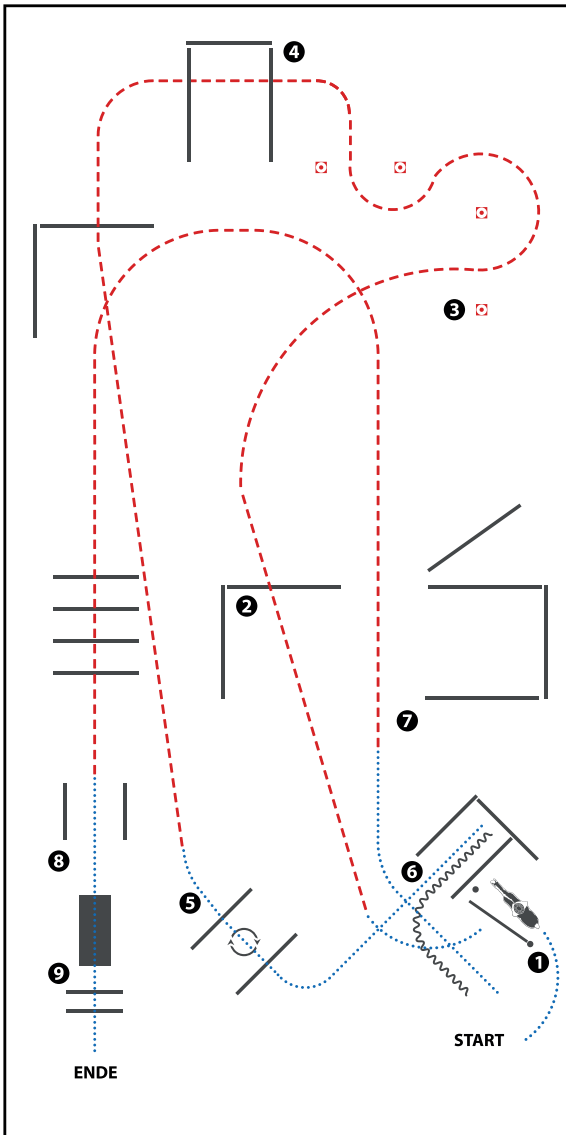

(Tor ist optional)

- 1) WALK, GATE, WALK (Schritt, Tor, schritt)
- 2) JOG OVER (Trabstangen)
- 3) JOG THRU MARKER (Trab durch Marker)
- 4) JOG OVER (Trabstangen)
- 5) WALK IN BOX, 360° TURN RIGHT, WALK OUT
(Im Schritt in die Box, 360° Wendung rechts, im Schritt aus der Box)
- 6) WALK INTO CHUTE, BACK UP
(Im Schritt in die Gasse, Rückwärts)
- 7) WALK, JOG OVER (Schritt, Trabstangen)
- 8) WALK OVER BRIDGE (Schritt über die Brücke)
- 9) WALK OVER (Schrittstangen)

WALK (SCHRITT)	
EXTENDED WALK	
JOG/TROT (TRAB)	
EXTENDED TROT	
LOPE (GALOPP)	
EXTENDED LOPE	
BACK UP (RÜCKWÄRTS)	
LEAD CHANGE (GALOPPWECHSEL)	
TURN (DREHUNG)	
	ERSTE
	WEITERER
	UNION
	WIEDERHOLER

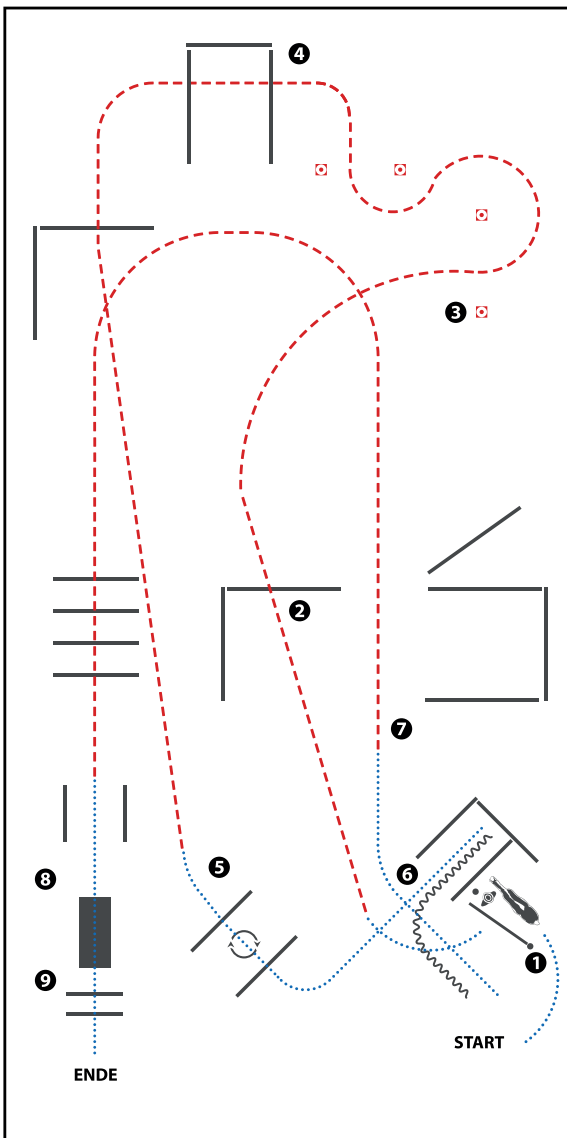

- 1) WALK, GATE, WALK
- 2) JOG OVER
- 3) JOG THRU MARKER
- 4) JOG OVER
- 5) WALK IN BOX, 360° TURN RIGHT, WALK OUT
- 6) WALK INTO CHUTE, BACK UP
- 7) WALK, JOG OVER
- 8) WALK OVER BRIDGE
- 9) WALK OVER

WALK (SCHRITT)	
EXTENDED WALK	
JOG/TROT (TRAB)	
EXTENDED TROT	
LOPE (GALOPP)	
EXTENDED LOPE	
BACK UP (RÜCKWÄRTS)	
LEAD CHANGE (GALOPPWECHSEL)	
TURN (DREHUNG)	
	ERSTE
	WESTENREITER
	UNION
	WELDPFERDEBUND WESTENREITER

Trail Set 8

Pattern 1-8

Arenagröße mind. 25 x 50 m

Für TH-Pattern gelten folgende Abstände und Maße:

WALK / WALK OVER	Abstand 40 - 60 cm • Erhöhung max. 30 cm. Bei Erhöhung sollte der Mindestabstand 55 cm betragen.
JOG / JOG OVER	Abstand 90 - 105 cm • Erhöhung max. 20 cm.
EXTENDED JOG	Abstand 105 - 125 cm.
LOPE / LOPE OVER	Abstand 180 - 210 cm • Erhöhung max. 20 cm.
EXTENDED LOPE	Abstand 210 - 225 cm.
BACK UP	Abstandmind. 100 cm, Erhöhung max. 30 cm.
SIDEPASS	Abstand in einer Gasse mind. 200 cm (ganzes Pferd), mind. 60 cm (1 Beinpaar zwischen zwei Stangen), Erhöhung max. 30 cm.
SERPENTIN WALK	Abstand mind. 200 cm
SERPENTIN JOG	Abstand mind. 250 cm
GATE	Breite mind. 90 cm, Länge 250 cm,
BRIDGE	Breite mind. 150 cm, Länge 250 cm,
BRIDGE WITH RAILING	Breite mind. 150 cm, Länge 250 cm,
BOX	Abstand 180 - 210 cm
JUMP	Erhöhung max. 45 cm

Zwischen den Hindernissen sollte eine:

Trabstrecke von mind. 10,00 m

Galoppstrecke von mind. 20,00 m

Volten sollten für Reiter der LK 5 und 4 nicht weniger als 12,00 m Durchmesser,
für LK 1 bis 3 nicht weniger als 10,00 m betragen

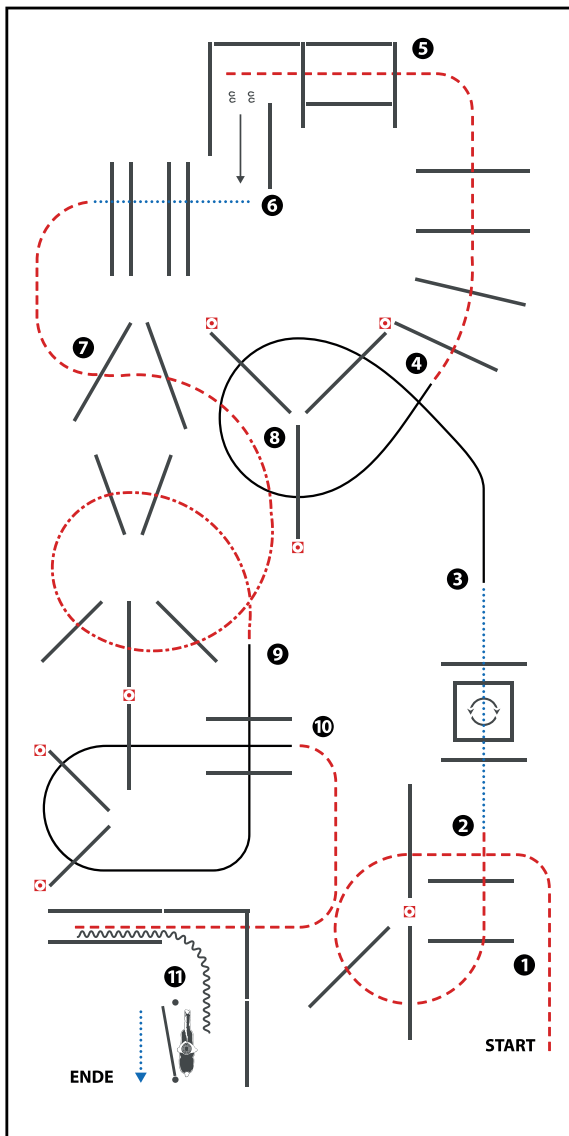

(Erhöhungen optional)

- 1) JOG OVER
- 2) WALK INTO BOX, TURN 360° EITHER WAY (LEFT OR RIGHT), WALK OUT
- 3) LOPE OVER (LL)
- 4) JOG OVER
- 5) JOG INTO CHUTE, SIDEPASS LEFT
- 6) WALK OVER
- 7) JOG OVER
- 8) EXTENDED JOG OVER
- 9) LOPE OVER (RL)
- 10) JOG INTO CHUTE, BACK UP
- 11) GATE

WALK (SCHRITT)	
EXTENDED WALK	
JOE/TROT (TRAB)	
EXTENDED TROT	
LOPE (GALOPP)	
EXTENDED LOPE	
BACK UP (RÜCKWÄRTS)	
LEAD CHANGE (GALOPPWECHSEL)	
TURN (DREHUNG)	
	ERSTE
	WESTENREITER
	UNION
	WELDPFERDEBUND WESTERWALD

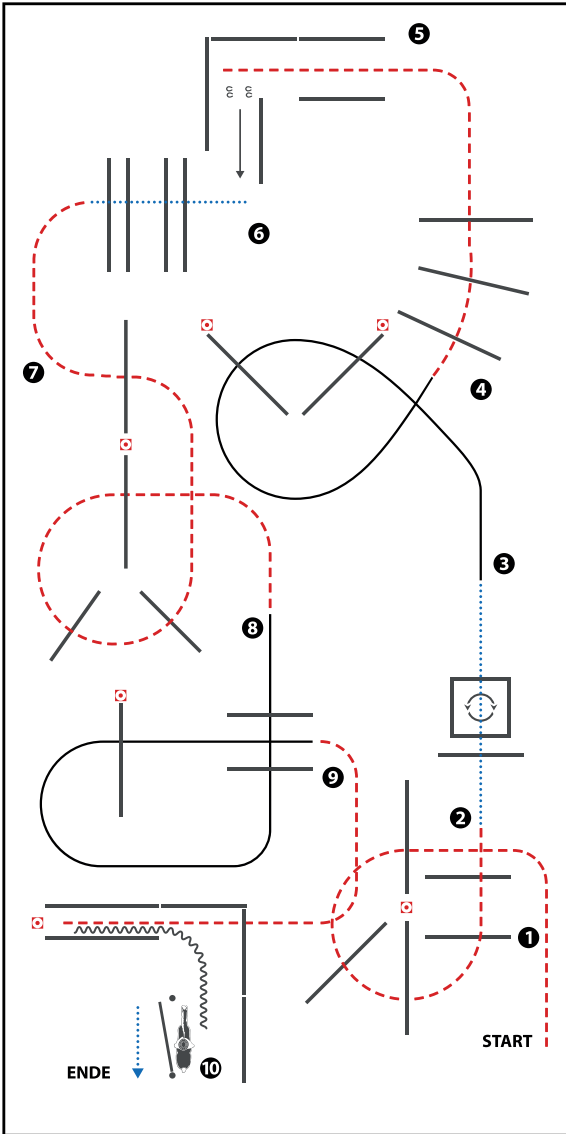

(Erhöhungen optional)

- 1) JOG OVER
- 2) WALK INTO BOX, TURN 360° EITHER WAY (LEFT OR RIGHT), WALK OUT
- 3) LOPE OVER (LL)
- 4) JOG OVER
- 5) JOG INTO CHUTE, SIDEPASS LEFT
- 6) WALK OVER
- 7) JOG OVER
- 8) LOPE OVER (RL)
- 9) JOG INTO CHUTE, BACK UP
- 10) GATE LEFT HAND

WALK (SCHRITT)	
EXTENDED WALK	
JOG/TROT (TRAB)	
EXTENDED TROT	
LOPE (GALOPP)	
EXTENDED LOPE	
BACK UP (RÜCKWÄRTS)	
LEAD CHANGE (GALOPPWECHSEL)	
TURN (DREHUNG)	
	ERSTE
	WESTSCHWEIZER
	UNION
	WIRTSCHAFTSUNIVERSITÄT

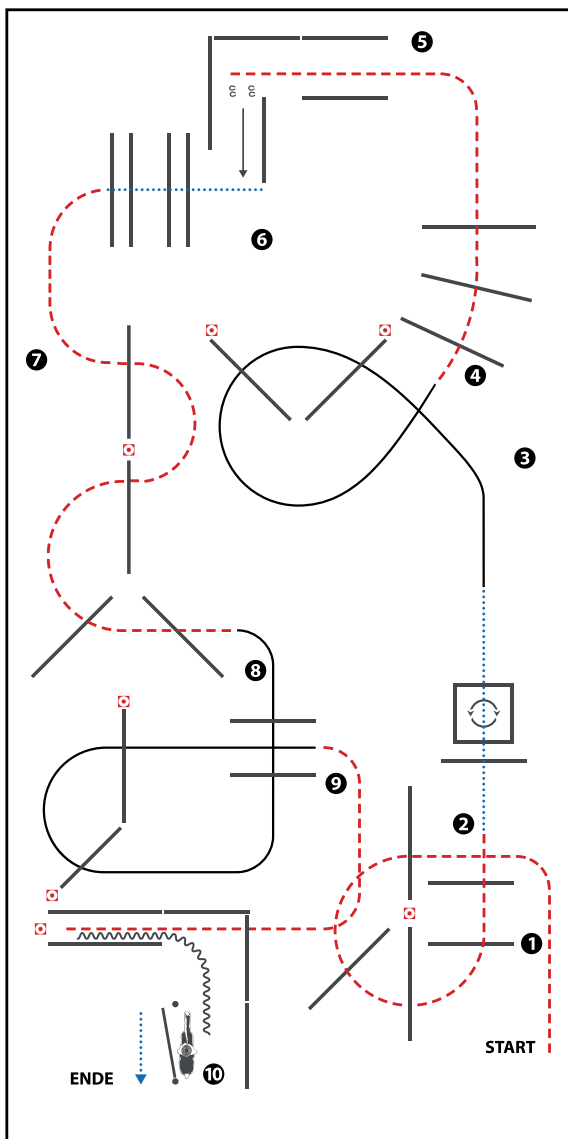

(Erhöhungen optional)

- 1) JOG OVER
- 2) WALK INTO BOX, TURN 360° EITHER WAY (LEFT OR RIGHT), WALK OUT
- 3) LOPE OVER (LL)
- 4) JOG OVER
- 5) JOG INTO CHUTE, SIDEPASS LEFT
- 6) WALK OVER
- 7) JOG OVER
- 8) LOPE OVER (RL)
- 9) JOG INTO CHUTE, BACK UP
- 10) GATE LEFT HAND

WALK (SCHRITT)	
EXTENDED WALK	
JOE/TROT (TRAB)	
EXTENDED TROT	
LOPE (GALOPP)	
EXTENDED LOPE	
BACK UP (RÜCKWÄRTS)	
LEAD CHANGE (GALOPPWECHSEL)	
TURN (DREHUNG)	
	ERSTE
	WESTSCHWEIZER
	UNION
	WIRTSCHAFTSUNIVERSITÄT

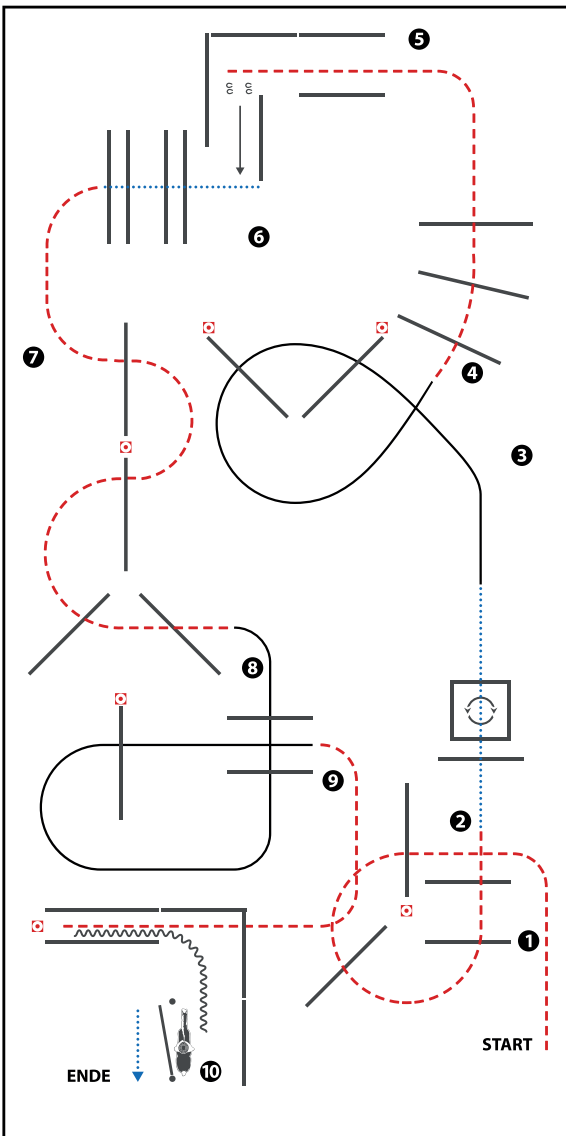

(Erhöhungen optional)

- 1) JOG OVER
- 2) WALK INTO BOX, TURN 360° EITHER WAY (LEFT OR RIGHT), WALK OUT
- 3) LOPE OVER (LL)
- 4) JOG OVER
- 5) JOG INTO CHUTE, SIDEPASS LEFT
- 6) WALK OVER
- 7) JOG OVER
- 8) LOPE OVER (RL)
- 9) JOG INTO CHUTE, BACK UP
- 10) GATE LEFT HAND

WALK (SCHRITT)	
EXTENDED WALK	
JOG/TROT (TRAB)	
EXTENDED TROT	
LOPE (GALOPP)	
EXTENDED LOPE	
BACK UP (RÜCKWÄRTS)	
LEAD CHANGE (GALOPPWECHSEL)	
TURN (DREHUNG)	
	ERSTE
	WESTENREITER
	UNION
	WELDPFERDEBUND WESTENREITER

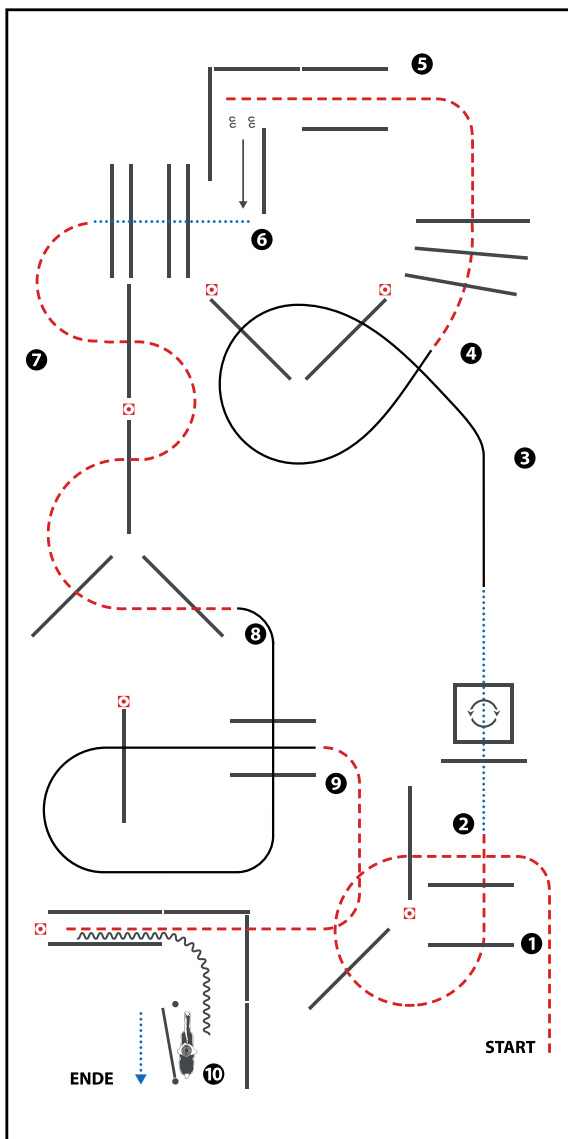

(Erhöhungen optional)

- 1) JOG OVER
- 2) WALK INTO BOX, TURN 360° EITHER WAY (LEFT OR RIGHT), WALK OUT
- 3) LOPE OVER (LL)
- 4) JOG OVER
- 5) JOG INTO CHUTE, SIDEPASS LEFT
- 6) WALK OVER
- 7) JOG OVER
- 8) LOPE OVER (RL)
- 9) JOG INTO CHUTE, BACK UP
- 10) GATE LEFT HAND

WALK (SCHRITT)	
EXTENDED WALK	
JOG/TROT (TRAB)	
EXTENDED TROT	
LOPE (GALOPP)	
EXTENDED LOPE	
BACK UP (RÜCKWÄRTS)	
LEAD CHANGE (GALOPPWECHSEL)	
TURN (DREHUNG)	
	ERSTE
	WESTENREITER
	UNION
	WELDPFERDEBUND DEUTSCHLAND

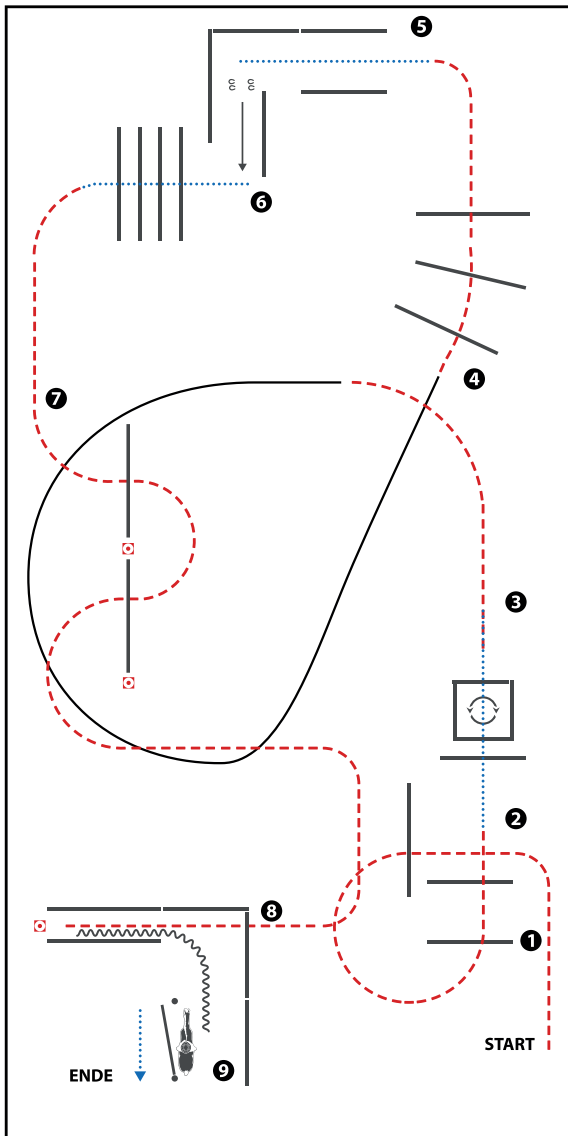

- 1) JOG OVER
- 2) WALK INTO BOX, TURN 360° EITHER WAY (LEFT OR RIGHT), WALK OUT
- 3) JOG, LOPE (LL)
- 4) JOG OVER
- 5) WALK INTO CHUTE, SIDEPASS LEFT
- 6) WALK OVER
- 7) JOG OVER
- 8) JOG INTO CHUTE, BACK UP
- 9) GATE LEFT HAND

WALK (SCHRITT)	
EXTENDED WALK	
JOG/TROT (TRAB)	
EXTENDED TROT	
LOPE (GALOPP)	
EXTENDED LOPE	
BACK UP (RÜCKWÄRTS)	
LEAD CHANGE (GALOPPWECHSEL)	
TURN (DREHUNG)	
	ERSTE
	WESTENREITER
	UNION
	WELDPFERDEBUND WESTENREITER

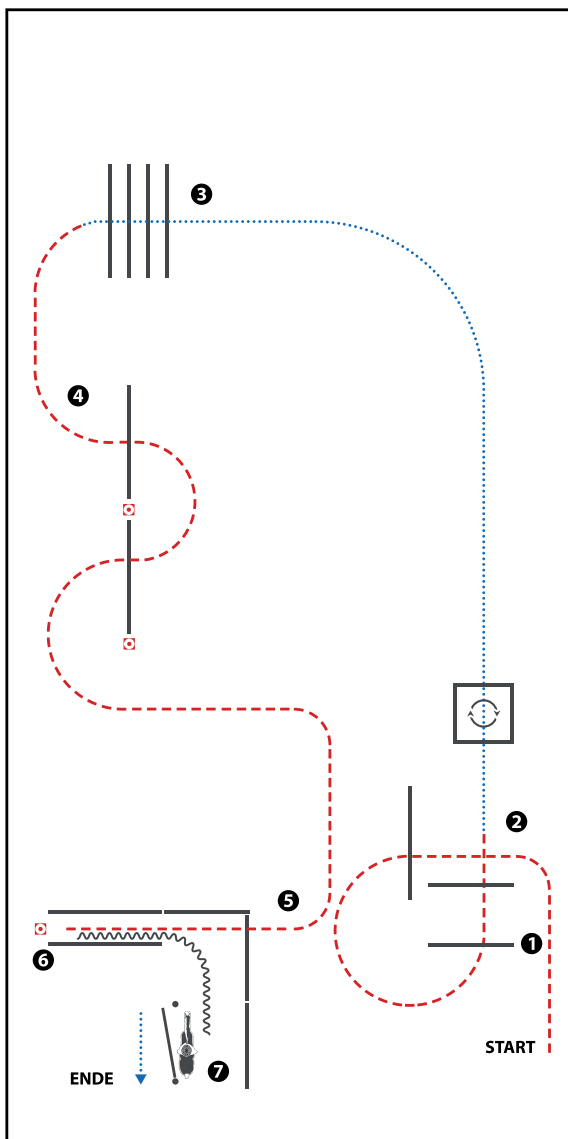

(Tor ist optional)

- 1) JOG OVER (Trabstangen)
- 2) WALK INTO BOX, 360° TURN RIGHT, WALK OUT
(Schritt in die Box, 360° Wendung rechts,
Schritt aus der Box)
- 3) WALK OVER (Schrittstangen)
- 4) JOG OVER (Trabstangen)
- 5) JOG INTO CHUTE (Trab in die Gasse)
- 6) BACK UP (Rückwärts)
- 7) GATE LEFT HAND (Tor, linke Hand)

WALK (SCHRITT)	
EXTENDED WALK	
JOG/TROT (TRAB)	
EXTENDED TROT	
LOPE (GALOPP)	
EXTENDED LOPE	
BACK UP (RÜCKWÄRTS)	
LEAD CHANGE (GALOPPWECHSEL)	
TURN (DREHUNG)	
ERSTE	
WESTENREITER	
UNION	
WELDPFERDEBUND DEUTSCHLAND	

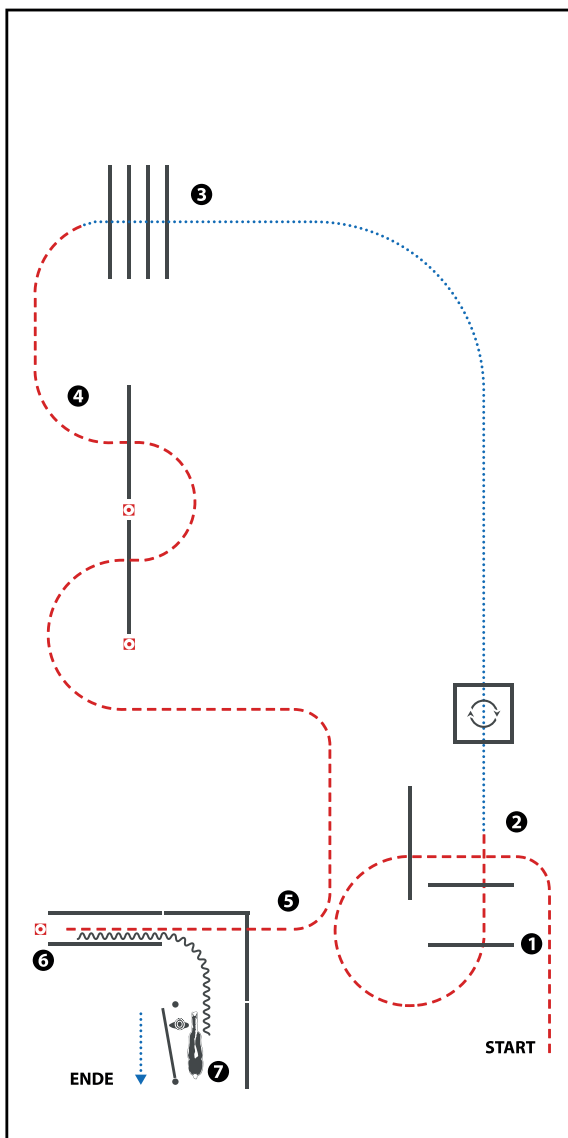

- 1) JOG OVER
- 2) WALK INTO BOX, 360° TURN RIGHT, WALK OUT
- 3) WALK OVER
- 4) JOG OVER
- 5) JOG INTO CHUTE
- 6) BACK UP
- 7) GATE LEFT HAND

WALK (SCHRITT)	
EXTENDED WALK	
JOG/TROT (TRAB)	
EXTENDED TROT	
LOPE (GALOPP)	
EXTENDED LOPE	
BACK UP (RÜCKWÄRTS)	
LEAD CHANGE (GALOPPWECHSEL)	
TURN (DREHUNG)	
	ERSTE
	WESTENREITER
	UNION
	WELDPFERDEBUND WELDPFERTE

Trail Set 9 mit Brücke

Pattern 1- 9

Arenagröße mind. 25 x 50 m

Für TH-Pattern gelten folgende Abstände und Maße:

WALK / WALK OVER	Abstand 40 - 60 cm • Erhöhung max. 30 cm. Bei Erhöhung sollte der Mindestabstand 55 cm betragen.
JOG / JOG OVER	Abstand 90 - 105 cm • Erhöhung max. 20 cm.
EXTENDED JOG	Abstand 105 - 125 cm.
LOPE / LOPE OVER	Abstand 180 - 210 cm • Erhöhung max. 20 cm.
EXTENDED LOPE	Abstand 210 - 225 cm.
BACK UP	Abstandmind. 100 cm, Erhöhung max. 30 cm.
SIDEPASS	Abstand in einer Gasse mind. 200 cm (ganzes Pferd), mind. 60 cm (1 Beinpaar zwischen zwei Stangen), Erhöhung max. 30 cm.
SERPENTIN WALK	Abstand mind. 200 cm
SERPENTIN JOG	Abstand mind. 250 cm
GATE	Breite mind. 90 cm, Länge 250 cm,
BRIDGE	Breite mind. 150 cm, Länge 250 cm,
BRIDGE WITH RAILING	Breite mind. 150 cm, Länge 250 cm,
BOX	Abstand 180 - 210 cm
JUMP	Erhöhung max. 45 cm

Zwischen den Hindernissen sollte eine:

Trabstrecke von mind. 10,00 m

Galoppstrecke von mind. 20,00 m

Volten sollten für Reiter der LK 5 und 4 nicht weniger als 12,00 m Durchmesser,
für LK 1 bis 3 nicht weniger als 10,00 m betragen

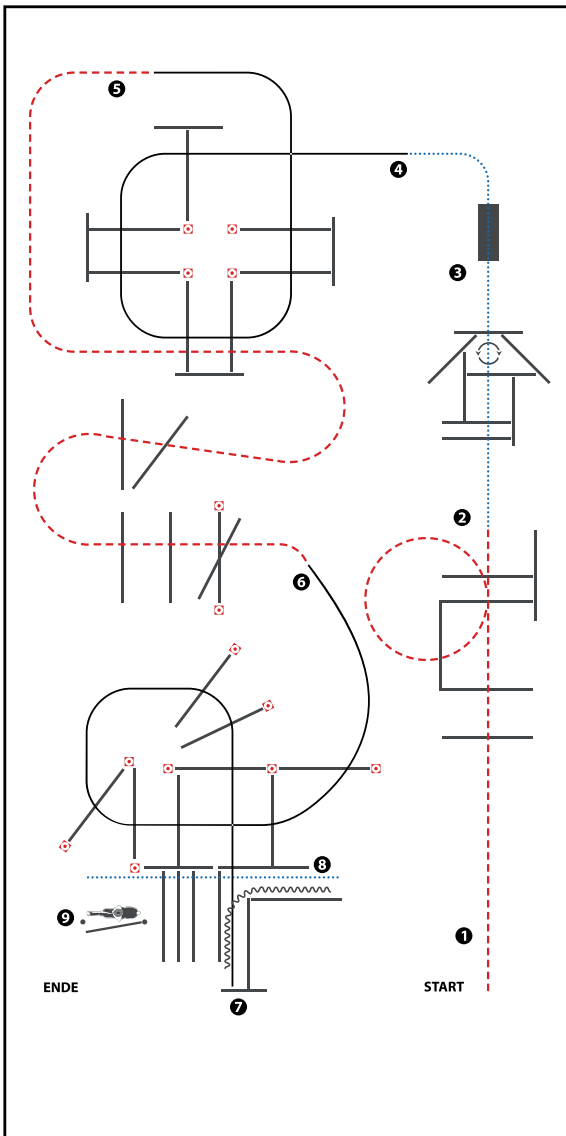

(Erhöhungen optional)

- 1) JOG OVER
- 2) WALK OVER, WALK INTO TRIANGLE, 360° TURN EITHER WAY (LEFT OR RIGHT), WALK OUT
- 3) WALK OVER BRIDGE
- 4) LOPE OVER (LL)
- 5) JOG OVER
- 6) LOPE OVER (RL), LOPE INTO CHUTE, STOP
- 7) BACK UP
- 8) WALK OVER
- 9) GATE LH

WALK (SCHRITT)	
EXTENDED WALK	
JOG/TROT (TRAB)	
EXTENDED TROT	
LOPE (GALOPP)	
EXTENDED LOPE	
BACK UP (RÜCKWÄRTS)	
LEAD CHANGE (GALOPPWECHSEL)	
TURN (DREHUNG)	
	ERSTE
	WESTENREITER
	UNION
	WELDPFERDEBUND WESTENREITER

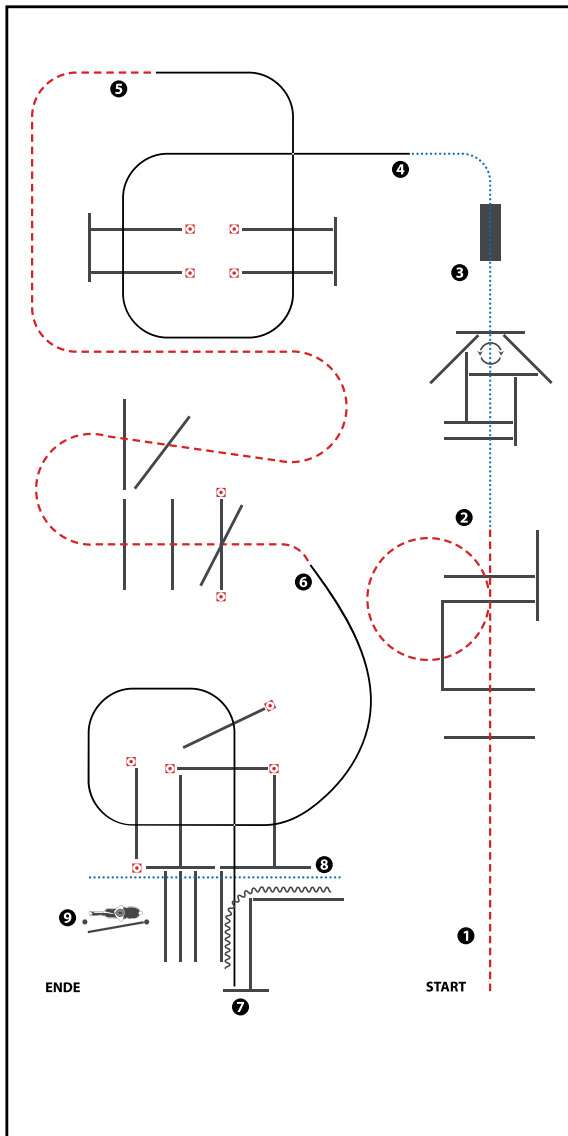

(Erhöhungen optional)

- 1) JOG OVER
- 2) WALK OVER, WALK INTO TRIANGLE, 360° TURN EITHER WAY (LEFT OR RIGHT), WALK OUT
- 3) WALK OVER BRIDGE
- 4) LOPE OVER (LL)
- 5) JOG OVER
- 6) LOPE OVER (RL), LOPE INTO CHUTE, STOP
- 7) BACK UP
- 8) WALK OVER
- 9) GATE LH

WALK (SCHRITT)	
EXTENDED WALK	
JOG/TROT (TRAB)	
EXTENDED TROT	
LOPE (GALOPP)	
EXTENDED LOPE	
BACK UP (RÜCKWÄRTS)	
LEAD CHANGE (GALOPPWECHSEL)	
TURN (DREHUNG)	
ERSTE	
WESTENREITER	
UNION	
WELDPFERDEBUND WESTENREITER	

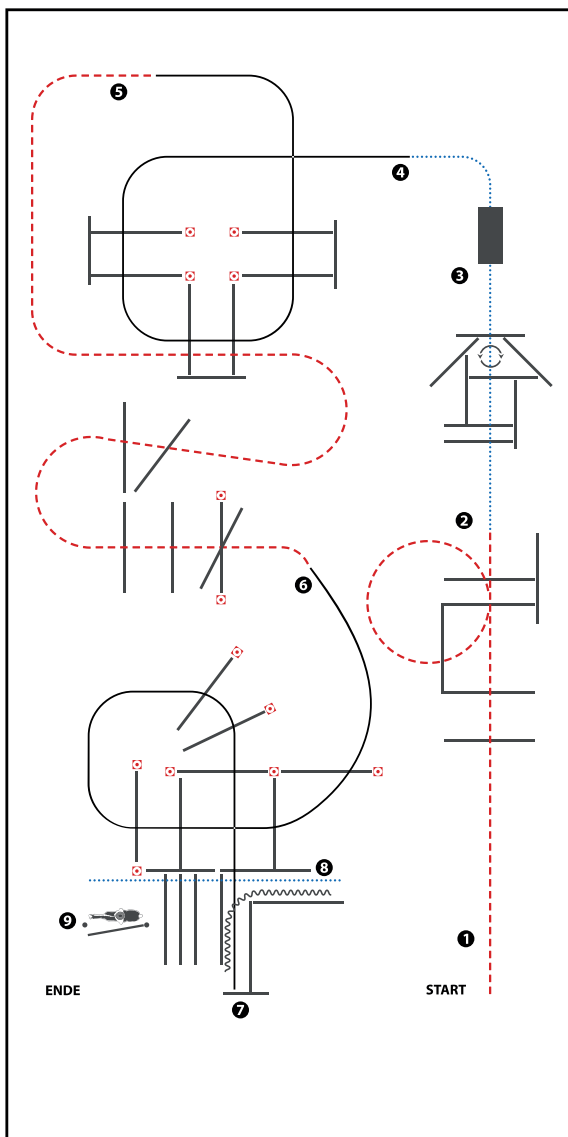

(Erhöhungen optional)

- 1) JOG OVER
- 2) WALK OVER, WALK INTO TRIANGLE, 360° TURN EITHER WAY (LEFT OR RIGHT), WALK OUT
- 3) WALK OVER BRIDGE
- 4) LOPE OVER (LL)
- 5) JOG OVER
- 6) LOPE OVER (RL), LOPE INTO CHUTE, STOP
- 7) BACK UP
- 8) WALK OVER
- 9) GATE LH

WALK (SCHRITT)	
EXTENDED WALK	
JOG/TROT (TRAB)	
EXTENDED TROT	
LOPE (GALOPP)	
EXTENDED LOPE	
BACK UP (RÜCKWÄRTS)	
LEAD CHANGE (GALOPPWECHSEL)	
TURN (DREHUNG)	
	ERSTE
	WESTENREITER
	UNION
	WELDPFERDEBUND WESTENREITER

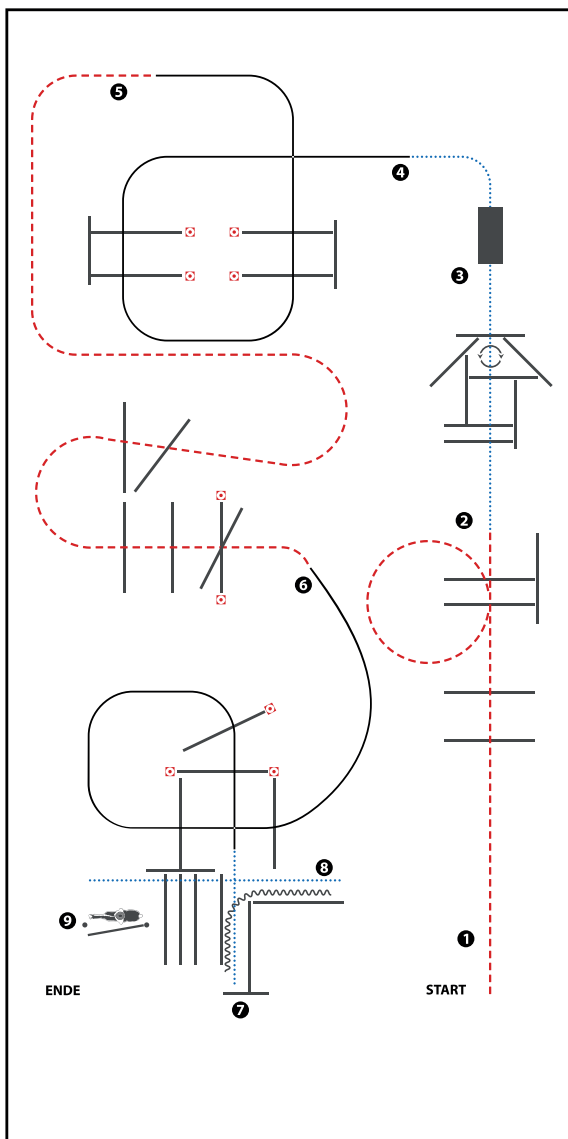

(Erhöhungen optional)

- 1) JOG OVER
- 2) WALK OVER, WALK INTO TRIANGLE, 360° TURN EITHER WAY (LEFT OR RIGHT), WALK OUT
- 3) WALK OVER BRIDGE
- 4) LOPE OVER (LL)
- 5) JOG OVER
- 6) LOPE OVER (RL), WALK INTO CHUTE, STOP
- 7) BACK UP
- 8) WALK OVER
- 9) GATE LH

WALK (SCHRITT)	
EXTENDED WALK	
JOG/TROT (TRAB)	
EXTENDED TROT	
LOPE (GALOPP)	
EXTENDED LOPE	
BACK UP (RÜCKWÄRTS)	
LEAD CHANGE (GALOPPWECHSEL)	
TURN (DREHUNG)	
ERSTE	
WESTENREITER	
UNION	
WELDPFERDEBUND WESTENREITER	

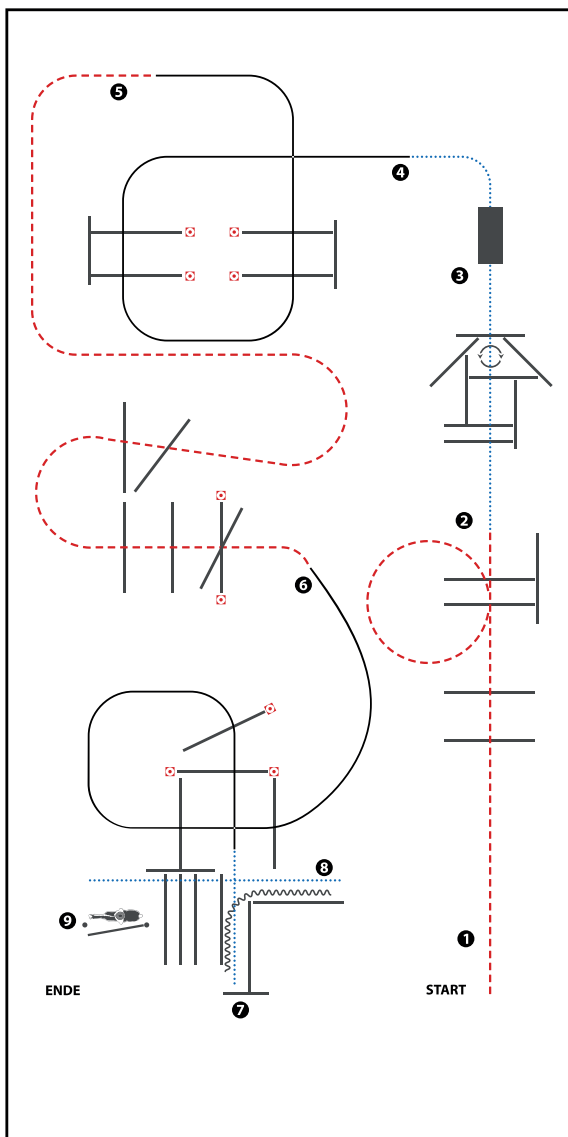

(Erhöhungen optional)

- 1) JOG OVER
- 2) WALK OVER, WALK INTO TRIANGLE,
360° TURN EITHER WAY (LEFT OR RIGHT), WALK OUT
- 3) WALK OVER BRIDGE
- 4) LOPE OVER (LL)
- 5) JOG OVER
- 6) LOPE OVER (RL), WALK INTO CHUTE, STOP
- 7) BACK UP
- 8) WALK OVER
- 9) GATE LH

WALK (SCHRITT)	
EXTENDED WALK	
JOG/TROT (TRAB)	
EXTENDED TROT	
LOPE (GALOPP)	
EXTENDED LOPE	
BACK UP (RÜCKWÄRTS)	
LEAD CHANGE (GALOPPWECHSEL)	
TURN (DREHUNG)	
	ERSTE
	WESTENREITER
	UNION
	WELDFORP/GERÄTE/WECHSELHÖHE

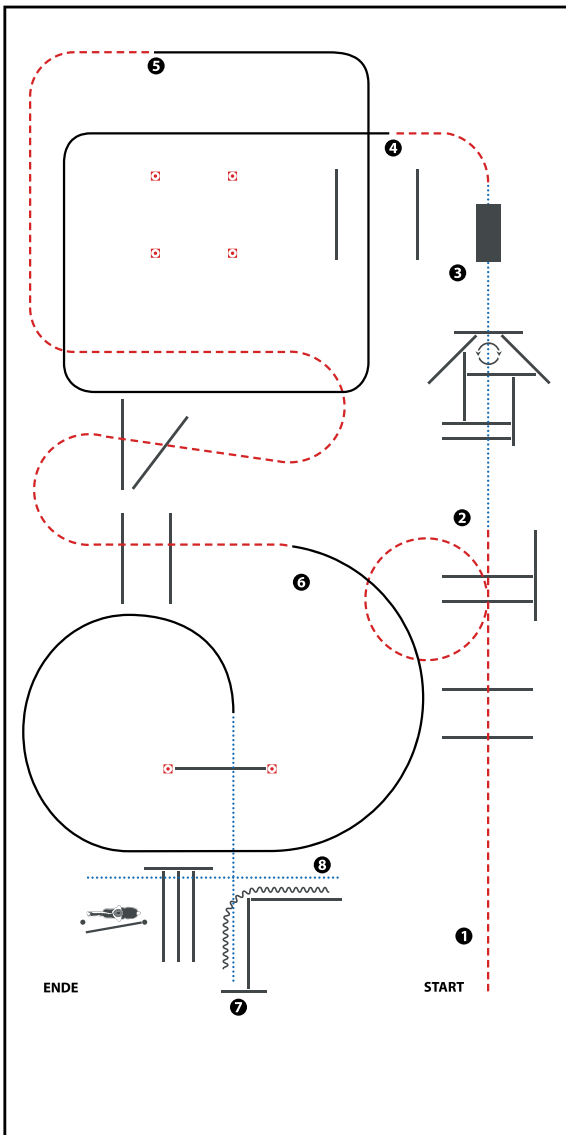

- 1) JOG OVER
- 2) WALK OVER, WALK INTO TRIANGLE,
360° TURN EITHER WAY (LEFT OR RIGHT), WALK OUT
- 3) WALK OVER BRIDGE
- 4) JOG, LOPE (LL)
- 5) JOG OVER
- 6) LOPE (RL), WALK OVER INTO CHUTE, STOP
- 7) BACK UP
- 8) WALK OVER
- 9) GATE LH

WALK (SCHRITT)	
EXTENDED WALK	
JOG/TROT (TRAB)	
EXTENDED TROT	
LOPE (GALOPP)	
EXTENDED LOPE	
BACK UP (RÜCKWÄRTS)	
LEAD CHANGE (GALOPPWECHSEL)	
TURN (DREHUNG)	
	ERSTE
	WESTENREITER
	UNION
	WORLDSPORTBRAND

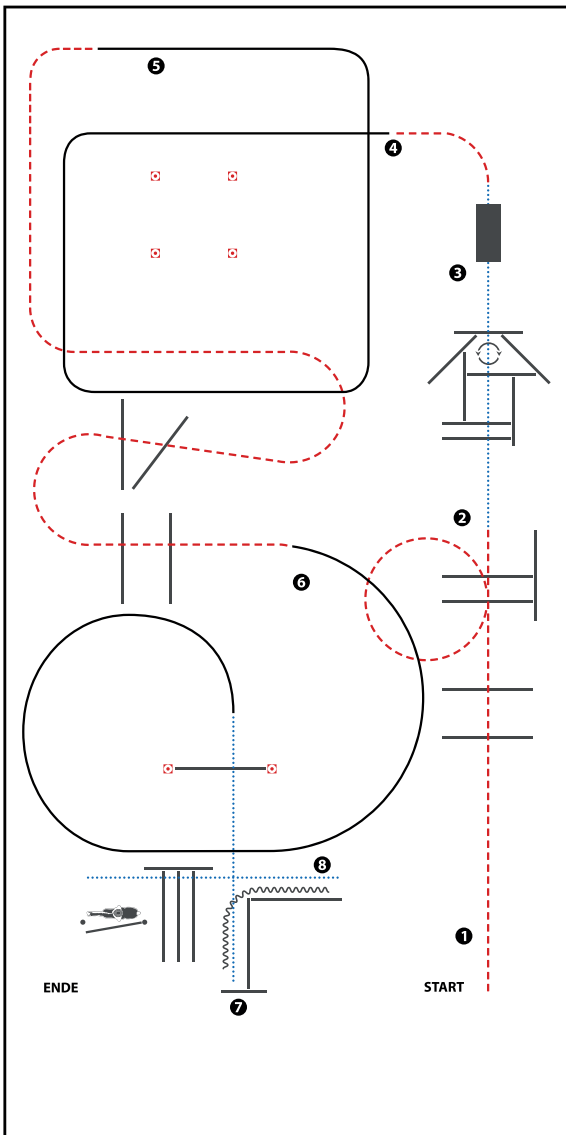

- 1) JOG OVER
- 2) WALK OVER, WALK INTO TRIANGLE,
360° TURN EITHER WAY (LEFT OR RIGHT), WALK OUT
- 3) WALK OVER BRIDGE
- 4) JOG, LOPE (LL)
- 5) JOG OVER
- 6) LOPE (RL), WALK OVER INTO CHUTE, STOP
- 7) BACK UP
- 8) WALK OVER
- 9) GATE LH

WALK (SCHRITT)	
EXTENDED WALK	
JOG/TROT (TRAB)	
EXTENDED TROT	
LOPE (GALOPP)	
EXTENDED LOPE	
BACK UP (RÜCKWÄRTS)	
LEAD CHANGE (GALOPPWECHSEL)	
TURN (DREHUNG)	
ERSTE	
WESTENREITER	
UNION	
WIEDERHOLER/REITER	

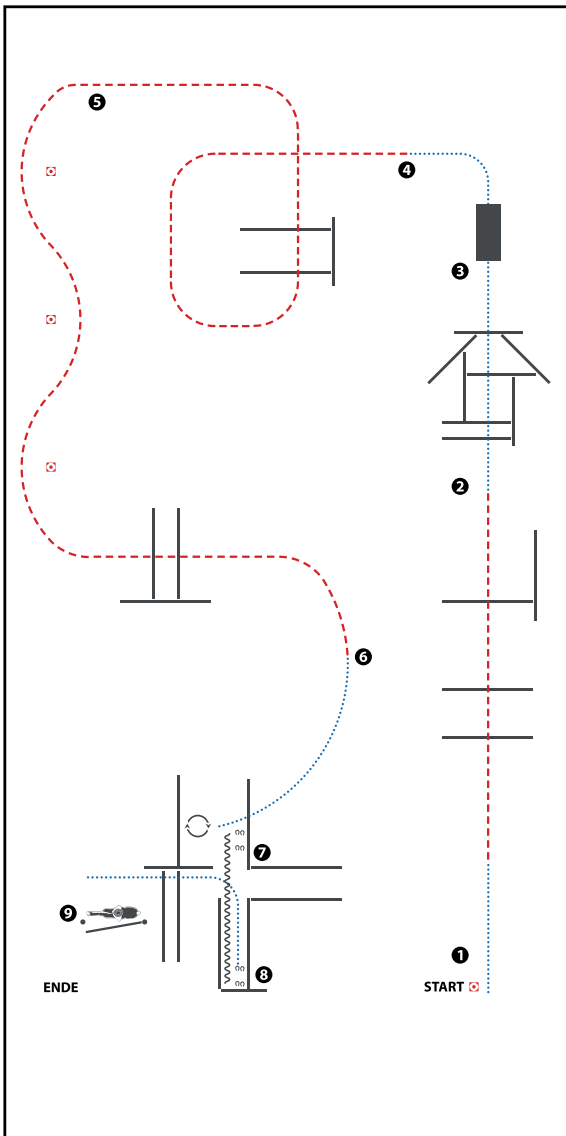

(Tor ist optional)

- 1) WALK, JOG OVER (Schritt, Trabstangen)
- 2) WALK OVER (Schrittstangen)
- 3) WALK OVER BRIDGE (Im Schritt über die Brücke)
- 4) JOG OVER (Trabstangen)
- 5) JOG SERPENTINE, JOG OVER (Slalom, Trabstangen)
- 6) WALK INTO BOX, 1 ¼ TURN RIGHT
(Im Schritt in die Box, 1 ¼ Wendung rechts)
- 7) BACK UP (Rückwärts)
- 8) WALK OVER (Schrittstangen)
- 9) GATE LH (Tor linke Hand)

WALK (SCHRI TT)
EXTENDED WALK
JOG/TROT (TRAB)	-----
EXTENDED TROT	-----
LOPE (GALOPP)	=====
EXTENDED LOPE	=====
BACK UP (RÜCKWÄRTS)	~~~~~
LEAD CHANGE (GALOPPWECHSEL)	=====
TURN (DREHUNG)	⤵
ERSTE	=====
WESTENREITER	=====
UNION	=====
WELDPFERDEBUND WESTENREITER	=====

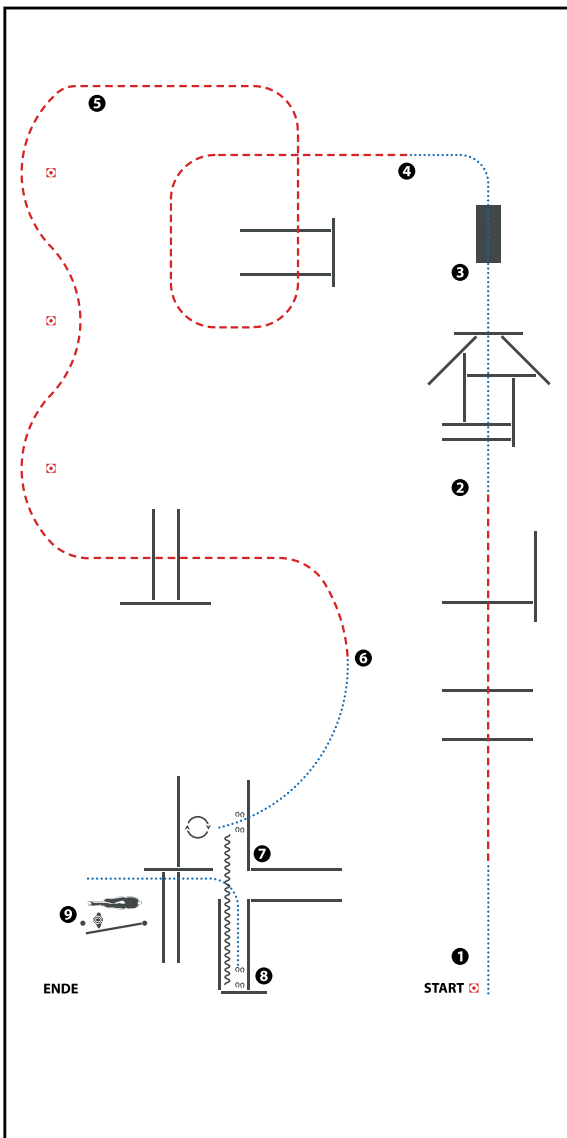

- 1) WALK, JOG OVER
- 2) WALK OVER
- 3) WALK OVER BRIDGE
- 4) JOG OVER
- 5) JOG SERPENTINE, JOG OVER
- 6) WALK INTO BOX, 1 ¼ TURN RIGHT
- 7) BACK UP
- 8) WALK OVER
- 9) GATE LH

WALK (SCHRITT)
EXTENDED WALK
JOG/TROT (TRAB)
EXTENDED TROT
LOPE (GALOPP)	=====
EXTENDED LOPE	=====
BACK UP (RÜCKWÄRTS)	~~~~~
LEAD CHANGE (GALOPPWECHSEL)	=====
TURN (DREHUNG)	⤵
ERSTE	=====
WESTENREITER	=====
UNION	=====
WIRTSCHAFTSCHAFTLICHE UNIVERSITÄT	=====

Trail Set 10

Pattern 1-8

Arenagröße mind. 20 x 40 m

Für TH-Pattern gelten folgende Abstände und Maße:

WALK / WALK OVER	Abstand 40 - 60 cm • Erhöhung max. 30 cm. Bei Erhöhung sollte der Mindestabstand 55 cm betragen.
JOG / JOG OVER	Abstand 90 - 105 cm • Erhöhung max. 20 cm.
EXTENDED JOG	Abstand 105 - 125 cm.
LOPE / LOPE OVER	Abstand 180 - 210 cm • Erhöhung max. 20 cm.
EXTENDED LOPE	Abstand 210 - 225 cm.
BACK UP	Abstandmind. 100 cm, Erhöhung max. 30 cm.
SIDEPASS	Abstand in einer Gasse mind. 200 cm (ganzes Pferd), mind. 60 cm (1 Beinpaar zwischen zwei Stangen), Erhöhung max. 30 cm.
SERPENTIN WALK	Abstand mind. 200 cm
SERPENTIN JOG	Abstand mind. 250 cm
GATE	Breite mind. 90 cm, Länge 250 cm,
BRIDGE	Breite mind. 150 cm, Länge 250 cm,
BRIDGE WITH RAILING	Breite mind. 150 cm, Länge 250 cm,
BOX	Abstand 180 - 210 cm
JUMP	Erhöhung max. 45 cm

Zwischen den Hindernissen sollte eine:

Trabstrecke von mind. 10,00 m

Galoppstrecke von mind. 20,00 m

Volten sollten für Reiter der LK 5 und 4 nicht weniger als 12,00 m Durchmesser,
für LK 1 bis 3 nicht weniger als 10,00 m betragen

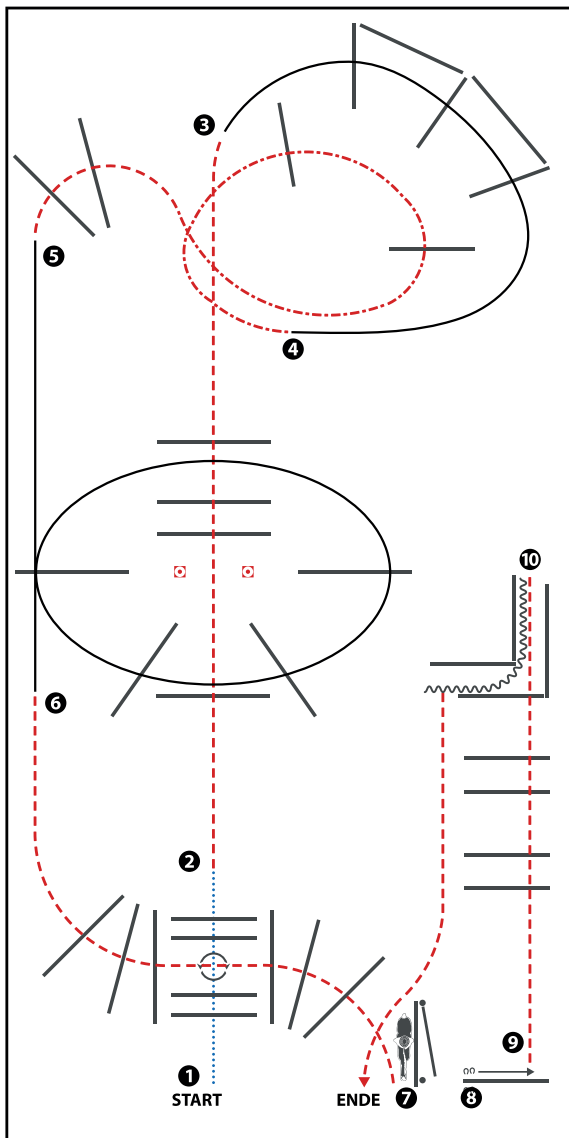

(Erhöhungen optional)

- 1) WALK OVER INTO BOX,
360° TURN (LEFT OR RIGHT), WALK OUT
- 2) JOG OVER
- 3) LOPE OVER (RL)
- 4) EXTENDED JOG OVER 2 POLES, JOG OVER 2POLES
- 5) LOPE OVER (LL)
- 6) JOG OVER
- 7) GATE LH WITH POLE
- 8) SIDEPASS RIGHT
- 9) JOG OVER POLES AND INTO CHUTE
- 10) BACK UP, 90° TURN RIGHT, JOG OUT

WALK (SCHRITT)
EXTENDED WALK
JOG/TROT (TRAB)	-----
EXTENDED TROT	-----
LOPE (GALOPP)	=====
EXTENDED LOPE	=====
BACK UP (RÜCKWÄRTS)	~~~~~
LEAD CHANGE (GALOPPWECHSEL)	=====
TURN (DREHUNG)	⤵
	ERSTE WESTENREITER UNION WIRTSCHAFTSUNIVERSITÄT WIEN

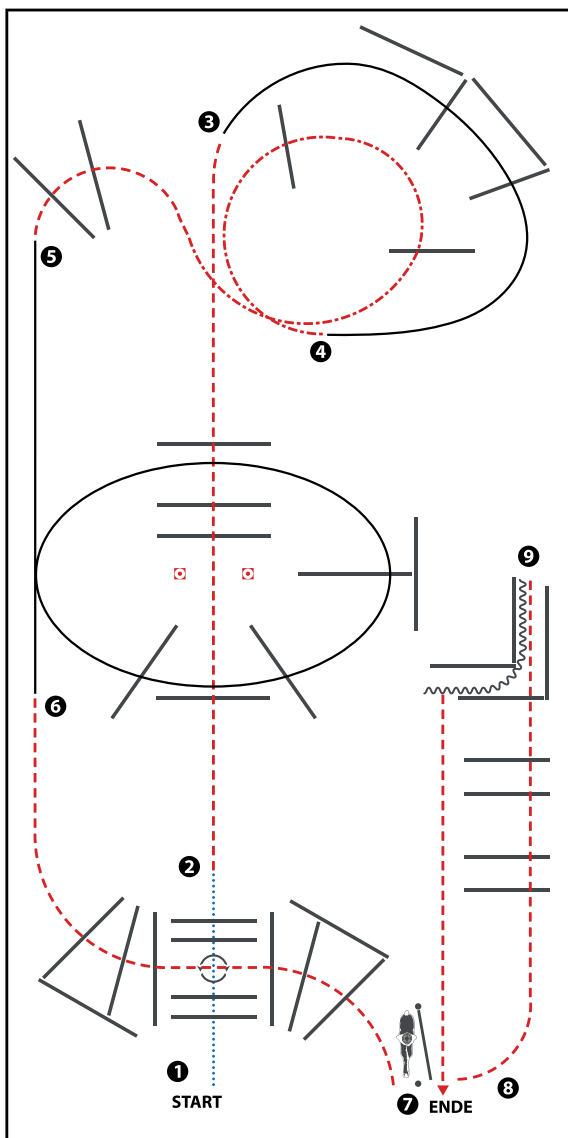

(Erhöhungen optional)

- 1) WALK OVER INTO BOX,
360° TURN (LEFT OR RIGHT), WALK OUT
- 2) JOG OVER
- 3) LOPE OVER (RL)
- 4) EXTENDED JOG OVER 2 POLES, JOG OVER 2 POLES
- 5) LOPE OVER (LL)
- 6) JOG OVER
- 7) GATE LH
- 8) JOG OVER POLES AND INTO CHUTE
- 9) BACK UP, 90° TURN RIGHT, JOG OUT

WALK (SCHRITT)
EXTENDED WALK	-----
JOG/TROT (TRAB)	- - - - -
EXTENDED TROT
LOPE (GALOPP)	—————
EXTENDED LOPE	—————
BACK UP (RÜCKWÄRTS)	~~~~~
LEAD CHANGE (GALOPPWECHSEL)	=====
TURN (DREHUNG)	
	ERSTE WESTERWEITER UNION WIRTSCHAFTSUNIVERSITÄT

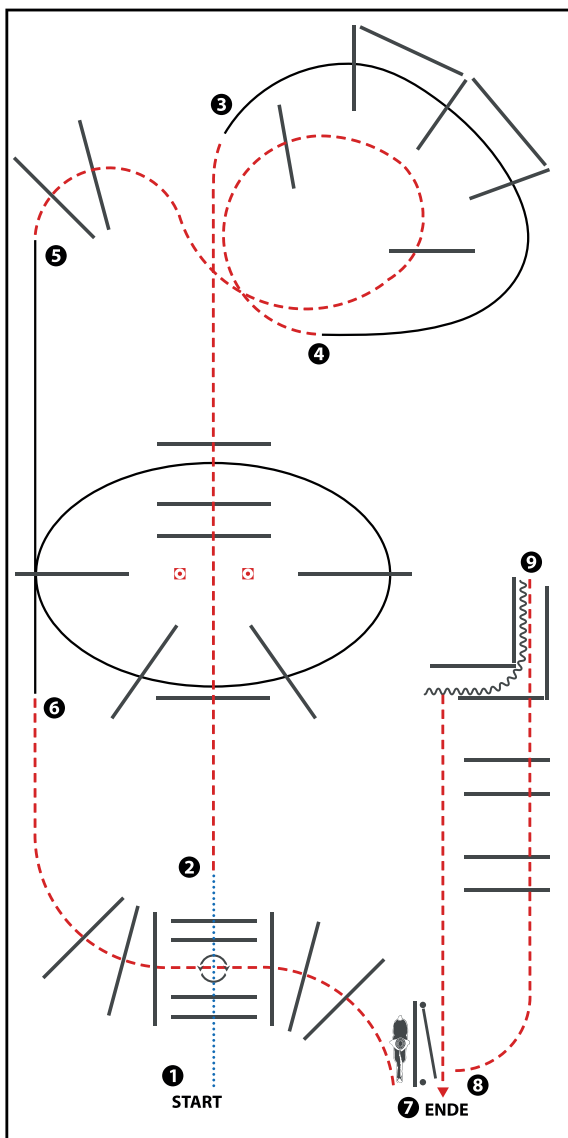

(Erhöhungen optional)

- 1) WALK OVER INTO BOX,
360° TURN (LEFT OR RIGHT), WALK OUT
- 2) JOG OVER
- 3) LOPE OVER (RL)
- 4) JOG OVER
- 5) LOPE OVER (LL)
- 6) JOG OVER
- 7) GATE LH
- 8) JOG OVER POLES AND INTO CHUTE
- 9) BACK UP, 90° TURN RIGHT, JOG OUT

WALK (SCHRITT)
EXTENDED WALK
JOG/TROT (TRAB)	-----
EXTENDED TROT	-----
LOPE (GALOPP)	-----
EXTENDED LOPE	-----
BACK UP (RÜCKWÄRTS)	~~~~~
LEAD CHANGE (GALOPPWECHSEL)	=====
TURN (DREHUNG)	⊙
ERSTE	-----
WESTENREITER	-----
UNION	-----
WESTENREITER	-----

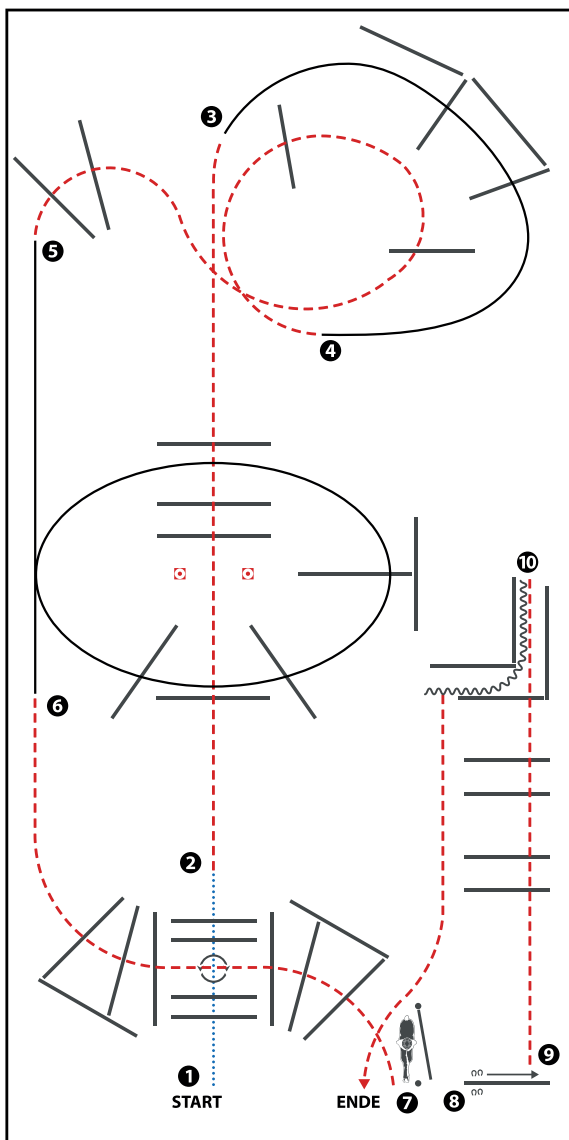

(Erhöhungen optional)

- 1) WALK OVER INTO BOX,
360° TURN (LEFT OR RIGHT), WALK OUT
- 2) JOG OVER
- 3) LOPE OVER (RL)
- 4) JOG OVER
- 5) LOPE OVER (LL)
- 6) JOG OVER
- 7) GATE LH
- 8) SIDEPASS RIGHT
- 9) JOG OVER POLES AND INTO CHUTE
- 10) BACK UP, 90° TURN RIGHT, JOG OUT

WALK (SCHRITT)
EXTENDED WALK
JOG/TROT (TRAB)	-----
EXTENDED TROT	-----
LOPE (GALOPP)	=====
EXTENDED LOPE	=====
BACK UP (RÜCKWÄRTS)	~~~~~
LEAD CHANGE (GALOPPWECHSEL)	=====
TURN (DREHUNG)	⤵
ERSTE	
WESTENREITER	
UNION	
WESTENREITER	

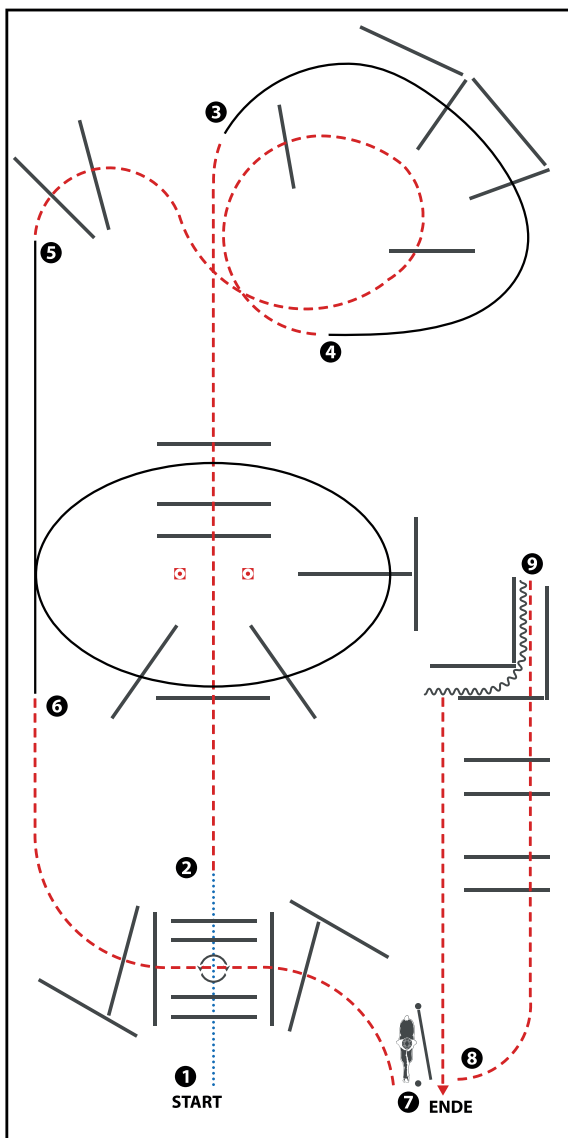

(Erhöhungen optional)

- 1) WALK OVER INTO BOX,
360° TURN (LEFT OR RIGHT), WALK OUT
- 2) JOG OVER
- 3) LOPE OVER (RL)
- 4) JOG OVER
- 5) LOPE OVER (LL)
- 6) JOG OVER
- 7) GATE LH
- 8) JOG OVER POLES AND INTO CHUTE
- 9) BACK UP, 90° TURN RIGHT, JOG OUT

WALK (SCHRITT)	
EXTENDED WALK	
JOG/TROT (TRAB)	
EXTENDED TROT	
LOPE (GALOPP)	
EXTENDED LOPE	
BACK UP (RÜCKWÄRTS)	
LEAD CHANGE (GALOPPWECHSEL)	
TURN (DREHUNG)	
	ERSTE
	WESTERREITER
	UNION
	WELDFÖRDERUNGSVERBAND

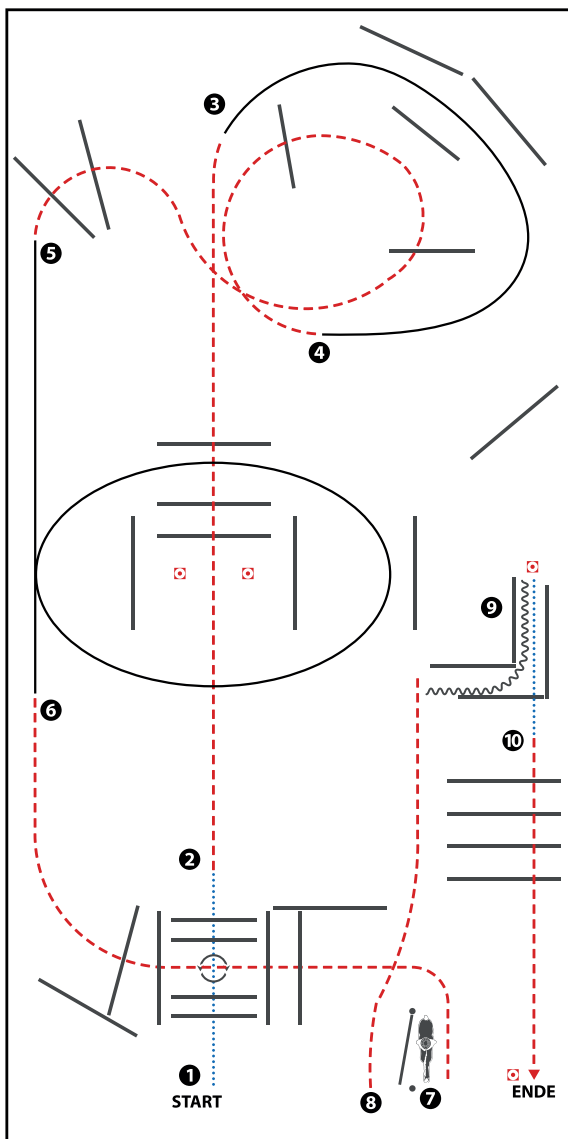

- 1) WALK OVER INTO BOX,
360° TURN (LEFT OR RIGHT), WALK OUT
- 2) JOG OVER
- 3) LOPE (RL)
- 4) JOG OVER
- 5) LOPE (LL)
- 6) JOG OVER
- 7) GATE RH
- 8) JOG, 90° TURN LEFT
- 9) BACK UP, WALK OUT
- 10) JOG OVER

WALK (SCHRITT)	
EXTENDED WALK	
JOG/TROT (TRAB)	
EXTENDED TROT	
LOPE (GALOPP)	
EXTENDED LOPE	
BACK UP (RÜCKWÄRTS)	
LEAD CHANGE (GALOPPWECHSEL)	
TURN (DREHUNG)	
	ERSTE
	WESTERREITER
	UNION
	WIRTSCHAFTSUNIVERSITÄT SIEGEN

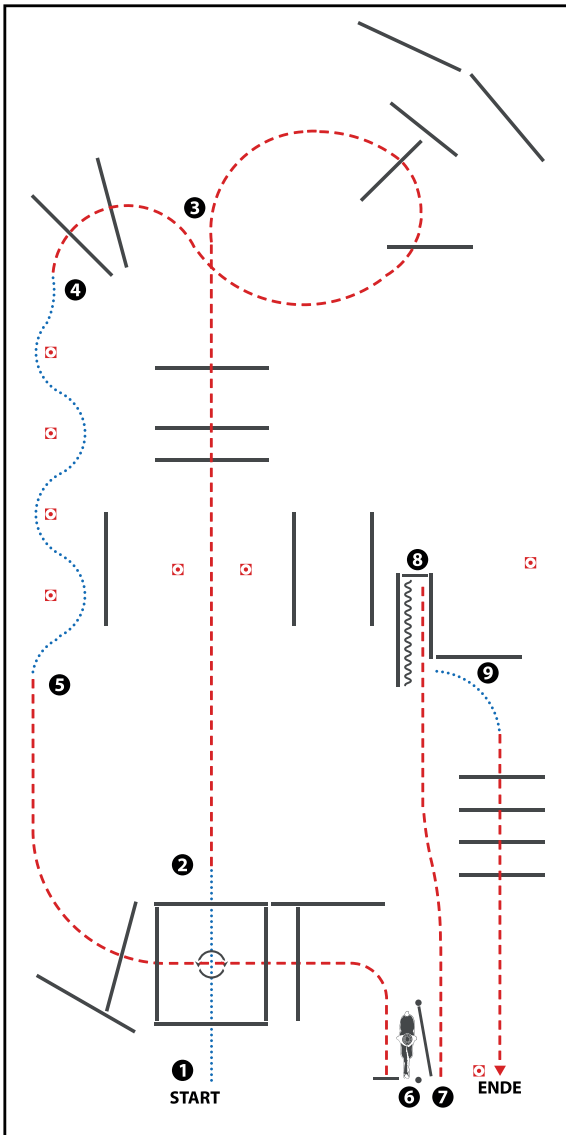

(Tor ist optional)

- 1) WALK INTO BOX, 360° TURN, WALK OUT
(Im Schritt in die Box, eine 360° Wendung rechts oder links, im Schritt aus der Box)
- 2) JOG OVER (Trabstangen)
- 3) JOG OVER (Trabstangen)
- 4) WALK SERPENTINE (Schritt Slalom)
- 5) JOG OVER (Trabstangen)
- 6) GATE LH (Tor linke Hand)
- 7) JOG INTO CHUTE (Trab in die Gasse)
- 8) BACK UP, TURN RIGHT (Rückwärts, nach rechts abwenden)
- 9) WALK, JOG OVER (Schritt, Trabstangen)

WALK (SCHRITT)	
EXTENDED WALK	
JOG/TROT (TRAB)	
EXTENDED TROT	
LOPE (GALOPP)	
EXTENDED LOPE	
BACK UP (RÜCKWÄRTS)	
LEAD CHANGE (GALOPPWECHSEL)	
TURN (DREHUNG)	
	ERSTE
	WESTENREITER
	UNION
	WELDFISCHEREI/REITERSCHAFT

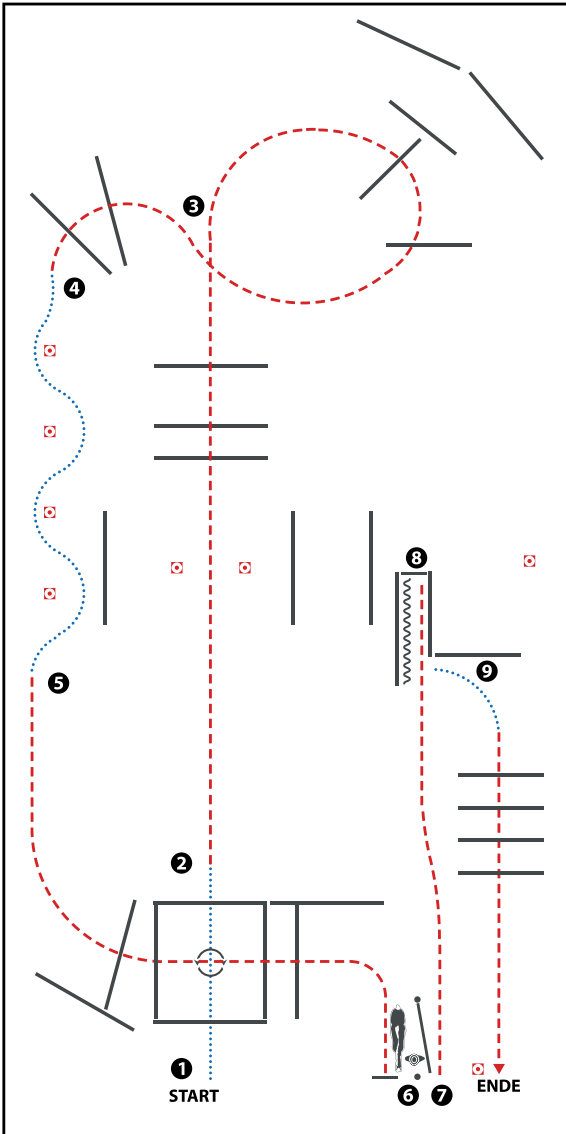

- 1) WALK INTO BOX, 360° TURN RIGHT WALK OUT
- 2) JOG OVER
- 3) JOG OVER
- 4) WALK SERPENTINE
- 5) JOG OVER
- 6) GATE LH
- 7) JOG INTO CHUTE
- 8) BACK UP, TURN RIGHT
- 9) WALK, JOG OVER

WALK (SCHRITT)	
EXTENDED WALK	
JOG/TROT (TRAB)	
EXTENDED TROT	
LOPE (GALOPP)	
EXTENDED LOPE	
BACK UP (RÜCKWÄRTS)	
LEAD CHANGE (GALLOPWECHSEL)	
TURN (DREHUNG)	

Trail Set 11 mit Brücke

Pattern 1- 8

Arenagröße mind. 25 x 50 m

Für TH-Pattern gelten folgende Abstände und Maße:

WALK / WALK OVER	Abstand 40 - 60 cm • Erhöhung max. 30 cm. Bei Erhöhung sollte der Mindestabstand 55 cm betragen.
JOG / JOG OVER	Abstand 90 - 105 cm • Erhöhung max. 20 cm.
EXTENDED JOG	Abstand 105 - 125 cm.
LOPE / LOPE OVER	Abstand 180 - 210 cm • Erhöhung max. 20 cm.
EXTENDED LOPE	Abstand 210 - 225 cm.
BACK UP	Abstandmind. 100 cm, Erhöhung max. 30 cm.
SIDEPASS	Abstand in einer Gasse mind. 200 cm (ganzes Pferd), mind. 60 cm (1 Beinpaar zwischen zwei Stangen), Erhöhung max. 30 cm.
SERPENTIN WALK	Abstand mind. 200 cm
SERPENTIN JOG	Abstand mind. 250 cm
GATE	Breite mind. 90 cm, Länge 250 cm,
BRIDGE	Breite mind. 150 cm, Länge 250 cm,
BRIDGE WITH RAILING	Breite mind. 150 cm, Länge 250 cm,
BOX	Abstand 180 - 210 cm
JUMP	Erhöhung max. 45 cm

Zwischen den Hindernissen sollte eine:

Trabstrecke von mind. 10,00 m

Galoppstrecke von mind. 20,00 m

Volten sollten für Reiter der LK 5 und 4 nicht weniger als 12,00 m Durchmesser,
für LK 1 bis 3 nicht weniger als 10,00 m betragen

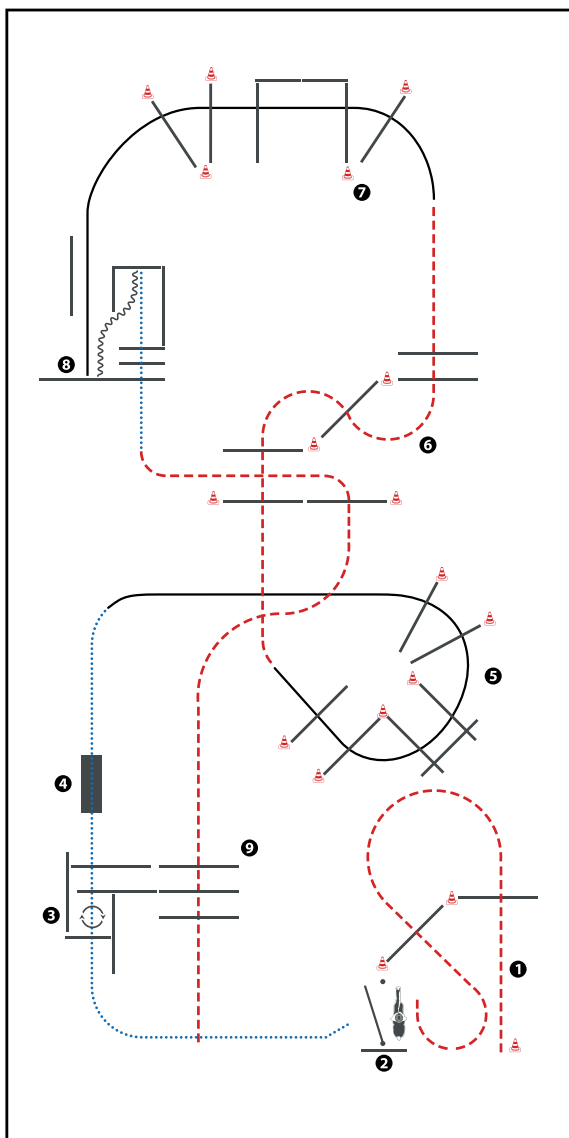

(Erhöhungen optional)

- 1) JOG, JOG OVER
- 2) GATE LEFT HAND
- 3) WALK INTO BOX, 360° TURN EITHER WAY (LEFT OR RIGHT), WALK OUT
- 4) WALK OVER BRIDGE
- 5) LOPE OVER (RL)
- 6) JOG OVER
- 7) LOPE OVER (LL), LOPE IN, STOP
- 8) BACK UP, WALK OUT, WALK OVER
- 9) JOG OVER
JOG OUT

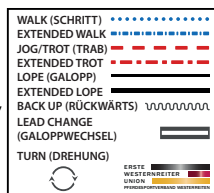

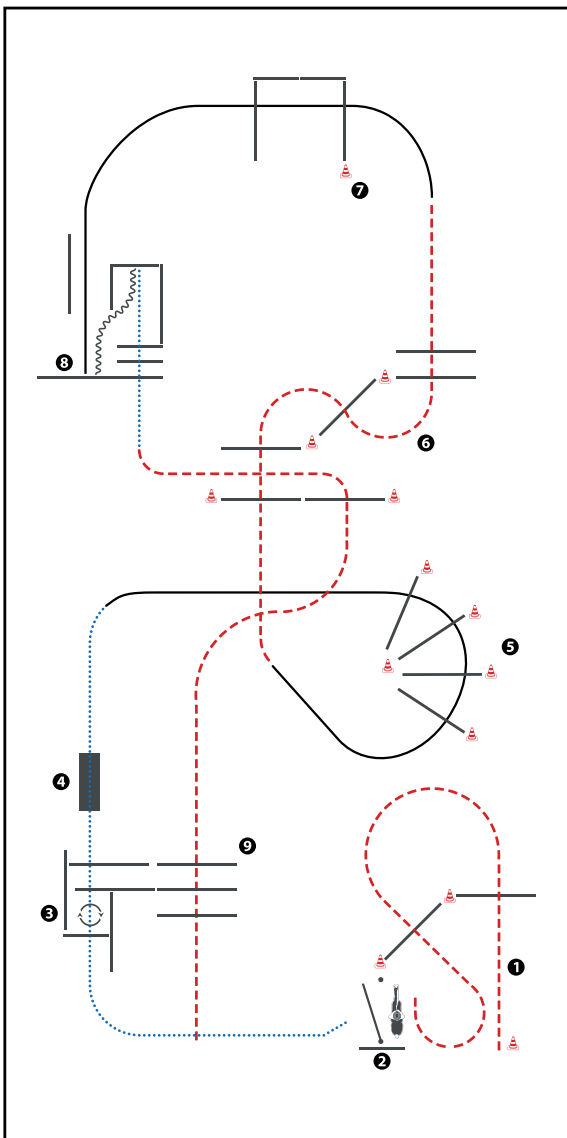

(Erhöhungen optional)

- 1) JOG, JOG OVER
- 2) GATE LEFT HAND
- 3) WALK INTO BOX, 360° TURN EITHER WAY (LEFT OR RIGHT), WALK OUT
- 4) WALK OVER BRIDGE
- 5) LOPE OVER (RL)
- 6) JOG OVER
- 7) LOPE OVER (LL), LOPE IN, STOP
- 8) BACK UP, WALK OUT, WALK OVER
- 9) JOG OVER
JOG OUT

WALK (SCHRITT)
EXTENDED WALK
JOG/TROT (TRAB)	-----
EXTENDED TROT	-----
LOPE (GALOPP)	=====
EXTENDED LOPE	=====
BACK UP (RÜCKWÄRTS)	~~~~~
LEAD CHANGE (GALOPPWECHSEL)	=====
TURN (DREHUNG)	⤵
	ERSTE WESTENREITER UNION WIRTSCHAFTSCHAFTLICHES VERBANDSGLIED

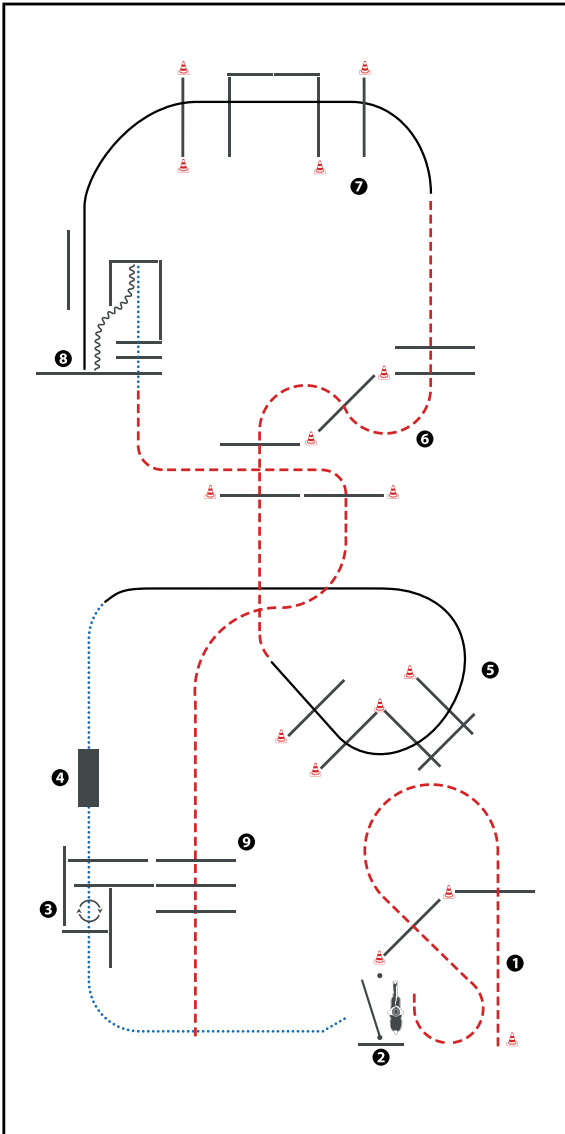

(Erhöhungen optional)

- 1) JOG, JOG OVER
- 2) GATE LEFT HAND
- 3) WALK INTO BOX, 360° TURN EITHER WAY (LEFT OR RIGHT), WALK OUT
- 4) WALK OVER BRIDGE
- 5) LOPE OVER (RL)
- 6) JOG OVER
- 7) LOPE OVER (LL), LOPE IN, STOP
- 8) BACK UP, WALK OUT, WALK OVER
- 9) JOG OVER
JOG OUT

WALK (SCHRITT)
EXTENDED WALK
JOG/TROT (TRAB)	-----
EXTENDED TROT	-----
LOPE (GALOPP)	=====
EXTENDED LOPE	=====
BACK UP (RÜCKWÄRTS)	~~~~~
LEAD CHANGE (GALOPPWECHSEL)	=====
TURN (DREHUNG)	⊙
	ERSTE WESTSCHWEIZER UNION PRODUKTIONSSCHAFT

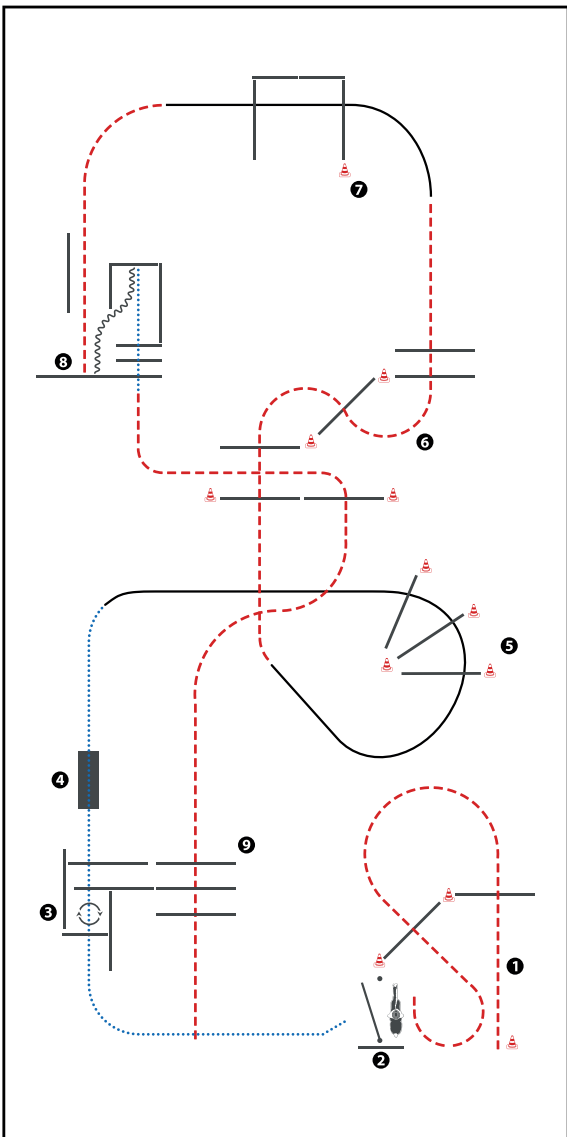

(Erhöhungen optional)

- 1) JOG, JOG OVER
- 2) GATE LEFT HAND
- 3) WALK INTO BOX, 360° TURN EITHER WAY (LEFT OR RIGHT), WALK OUT
- 4) WALK OVER BRIDGE
- 5) LOPE OVER (RL)
- 6) JOG OVER
- 7) LOPE OVER (LL), JOG IN, STOP
- 8) BACK UP, WALK OUT, WALK OVER
- 9) JOG OVER
JOG OUT

WALK (SCHRITT)
EXTENDED WALK
JOG/TROT (TRAB)	- - - - -
EXTENDED TROT	- - - - -
LOPE (GALOPP)	—————
EXTENDED LOPE	—————
BACK UP (RÜCKWÄRTS)	~~~~~
LEAD CHANGE (GALOPPWECHSEL)	—————
TURN (DREHUNG)	⊖
ERSTE	—————
WESTENREITER	—————
UNION	—————
WESTENREITER	—————

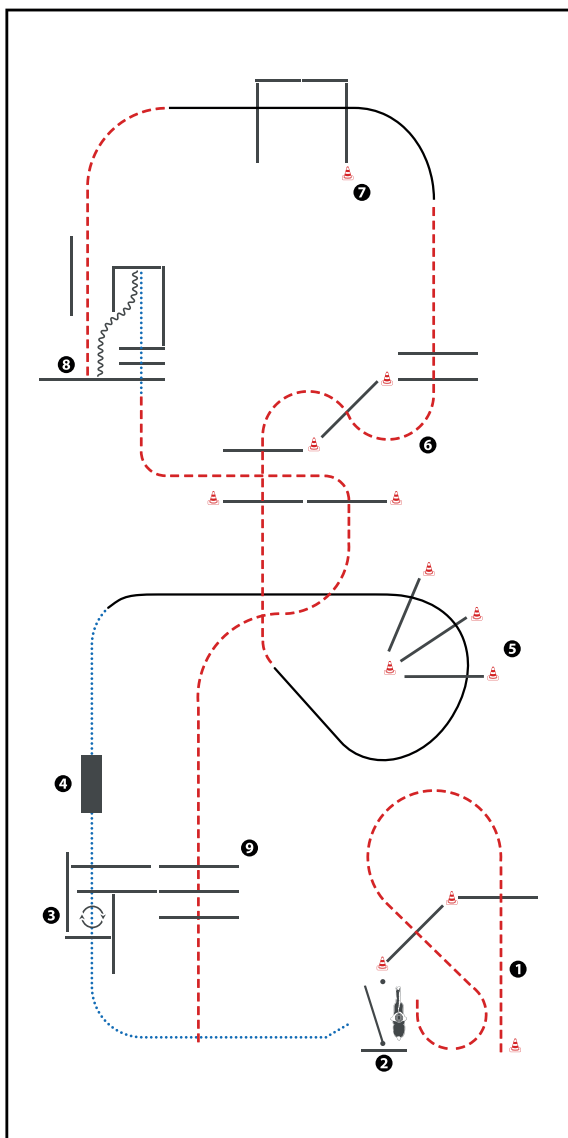

(Erhöhungen optional)

- 1) JOG, JOG OVER
- 2) GATE LEFT HAND
- 3) WALK INTO BOX, 360° TURN EITHER WAY (LEFT OR RIGHT), WALK OUT
- 4) WALK OVER BRIDGE
- 5) LOPE OVER (RL)
- 6) JOG OVER
- 7) LOPE OVER (LL), JOG IN, STOP
- 8) BACK UP, WALK OUT, WALK OVER
- 9) JOG OVER
JOG OUT

WALK (SCHRITT)	
EXTENDED WALK	
JOG/TROT (TRAB)	
EXTENDED TROT	
LOPE (GALOPP)	
EXTENDED LOPE	
BACK UP (RÜCKWÄRTS)	
LEAD CHANGE (GALOPPWECHSEL)	
TURN (DREHUNG)	
	ERSTE
	WESTENREITER
	UNION
	WIEDERHOLER/REITER

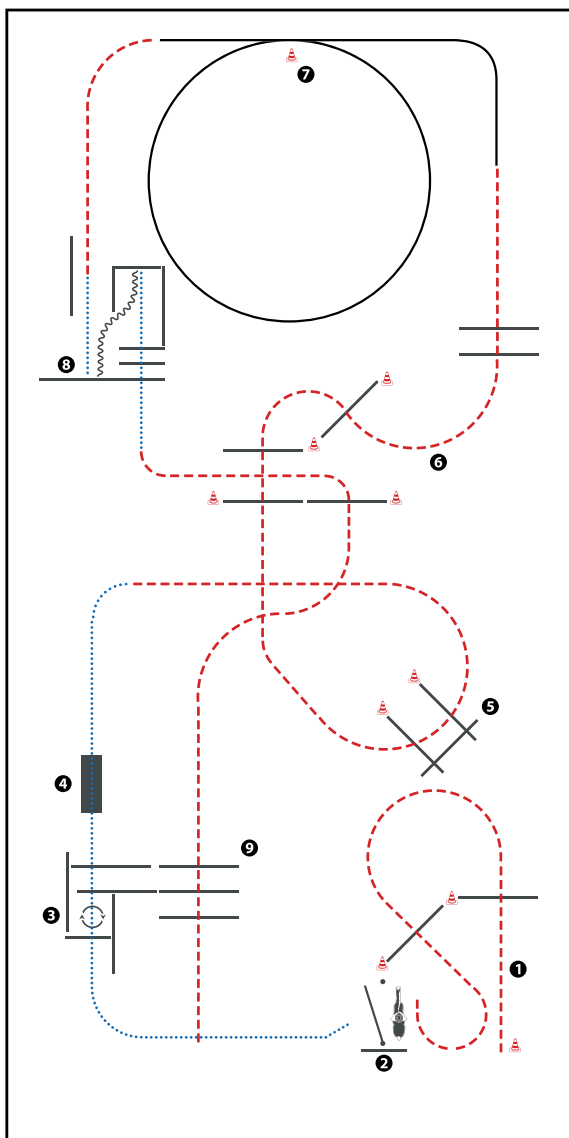

(Erhöhungen optional)

- 1) JOG, JOG OVER
- 2) GATE LEFT HAND
- 3) WALK INTO BOX, 360° TURN EITHER WAY (LEFT OR RIGHT), WALK OUT
- 4) WALK OVER BRIDGE
- 5) JOG OVER
- 6) JOG OVER
- 7) LOPE (LL), JOG, WALK IN, STOP
- 8) BACK UP, WALK OUT, JOG OUT
- 9) JOG OVER

WALK (SCHRITT)	
EXTENDED WALK	
JOG/TROT (TRAB)	
EXTENDED TROT	
LOPE (GALOPP)	
EXTENDED LOPE	
BACK UP (RÜCKWÄRTS)	
LEAD CHANGE (GALOPPWECHSEL)	
TURN (DREHUNG)	
ERSTE	
WESTENREITER	
UNION	
WELDPFERDEBUND WESTERWALD	

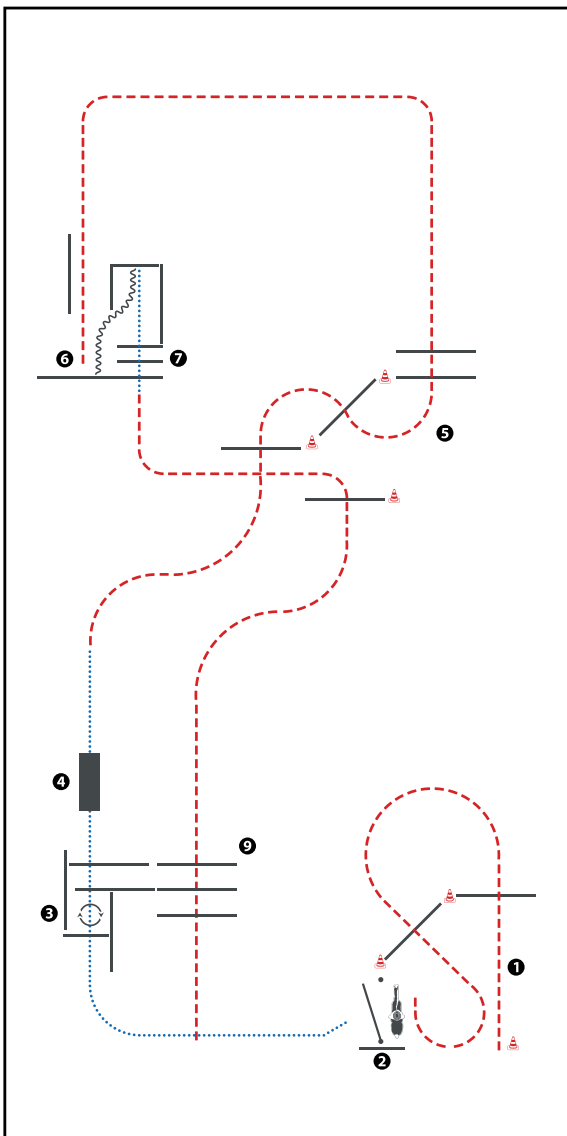

(Erhöhungen optional)

- 1) JOG, JOG OVER (Trab, Trabstangen)
- 2) GATE LEFT HAND (Tor linke Hand)
- 3) WALK INTO BOX, 360° TURN EITHER WAY, WALK OUT
(im Schritt in die Box, 360° Drehung links oder rechts)
- 4) WALK OVER BRIDGE (Schrittstangen, Brücke)
- 5) JOG OVER, JOG IN, STOP (Trabstangen, im Trab in die Gasse, Stop)
- 6) BACK UP (Rückwärts)
- 7) WALK OUT, WALK OVER (Schrittstangen)
- 8) JOG OVER (Trabstangen)
JOG OUT

WALK (SCHRITT)	
EXTENDED WALK	
JOG/TROT (TRAB)	
EXTENDED TROT	
LOPE (GALOPP)	
EXTENDED LOPE	
BACK UP (RÜCKWÄRTS)	
LEAD CHANGE (GALOPPWECHSEL)	
TURN (DREHUNG)	
ERSTE	
WESTENREITER	
UNION	
WELDPFERDEBUND WESTENREITER	

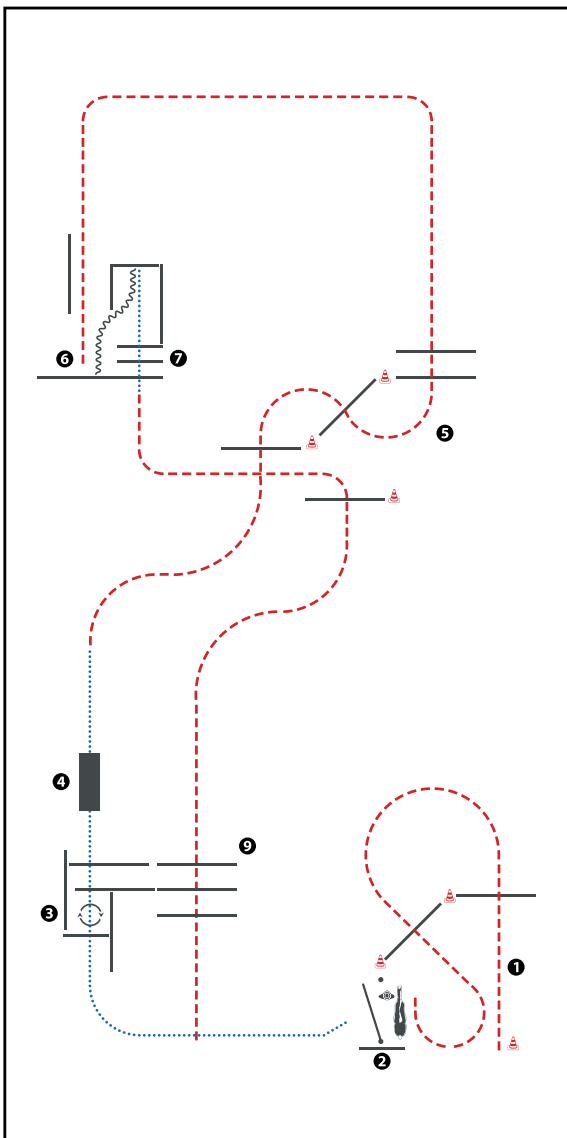

- 1) JOG, JOG OVER
- 2) GATE LEFT HAND
- 3) WALK INTO BOX, 360° TURN RIGHT, WALK OUT
- 4) WALK OVER BRIDGE
- 5) JOG OVER, JOG IN, STOP
- 6) BACK UP, WALK OUT, WALK OVER
- 7) JOG OVER
JOG OUT

WALK (SCHRITT)
EXTENDED WALK
JOG/TROT (TRAB)
EXTENDED TROT
LOPE (GALOPP)
EXTENDED LOPE
BACK UP (RÜCKWÄRTS)
LEAD CHANGE (GALOPPWECHSEL)
TURN (DREHUNG)
	ERSTE WESTENREITER UNION WIRTSCHAFTSCHAFTLICHE UNIVERSITÄT

Trail Set 12

Pattern 1-11

Arenagröße mind. 25 x 50 m

Für TH-Pattern gelten folgende Abstände und Maße:

WALK / WALK OVER	Abstand 40 - 60 cm • Erhöhung max. 30 cm. Bei Erhöhung sollte der Mindestabstand 55 cm betragen.
JOG / JOG OVER	Abstand 90 - 105 cm • Erhöhung max. 20 cm.
EXTENDED JOG	Abstand 105 - 125 cm.
LOPE / LOPE OVER	Abstand 180 - 210 cm • Erhöhung max. 20 cm.
EXTENDED LOPE	Abstand 210 - 225 cm.
BACK UP	Abstandmind. 100 cm, Erhöhung max. 30 cm.
SIDEPASS	Abstand in einer Gasse mind. 200 cm (ganzes Pferd), mind. 60 cm (1 Beinpaar zwischen zwei Stangen), Erhöhung max. 30 cm.
SERPENTIN WALK	Abstand mind. 200 cm
SERPENTIN JOG	Abstand mind. 250 cm
GATE	Breite mind. 90 cm, Länge 250 cm,
BRIDGE	Breite mind. 150 cm, Länge 250 cm,
BRIDGE WITH RAILING	Breite mind. 150 cm, Länge 250 cm,
BOX	Abstand 180 - 210 cm
JUMP	Erhöhung max. 45 cm

Zwischen den Hindernissen sollte eine:

Trabstrecke von mind. 10,00 m

Galoppstrecke von mind. 20,00 m

Volten sollten für Reiter der LK 5 und 4 nicht weniger als 12,00 m Durchmesser,
für LK 1 bis 3 nicht weniger als 10,00 m betragen

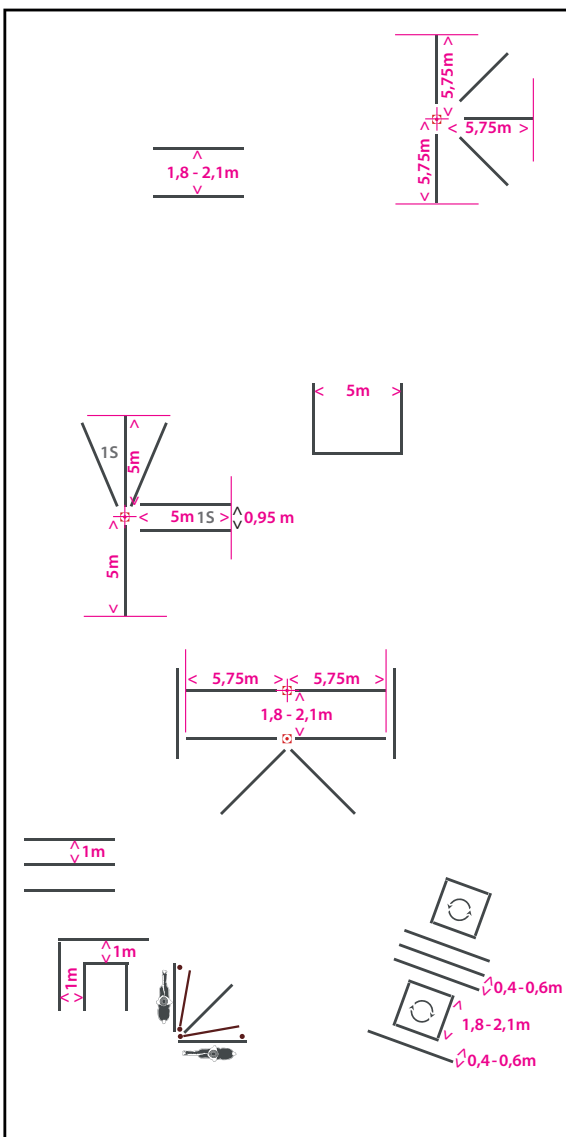

Bitte immer von der Pylone Mitte aus nach rechts, links oder oben und unten messen.
Beispiel wie gemessen werden sollte.

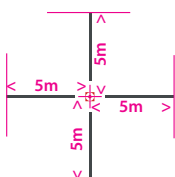

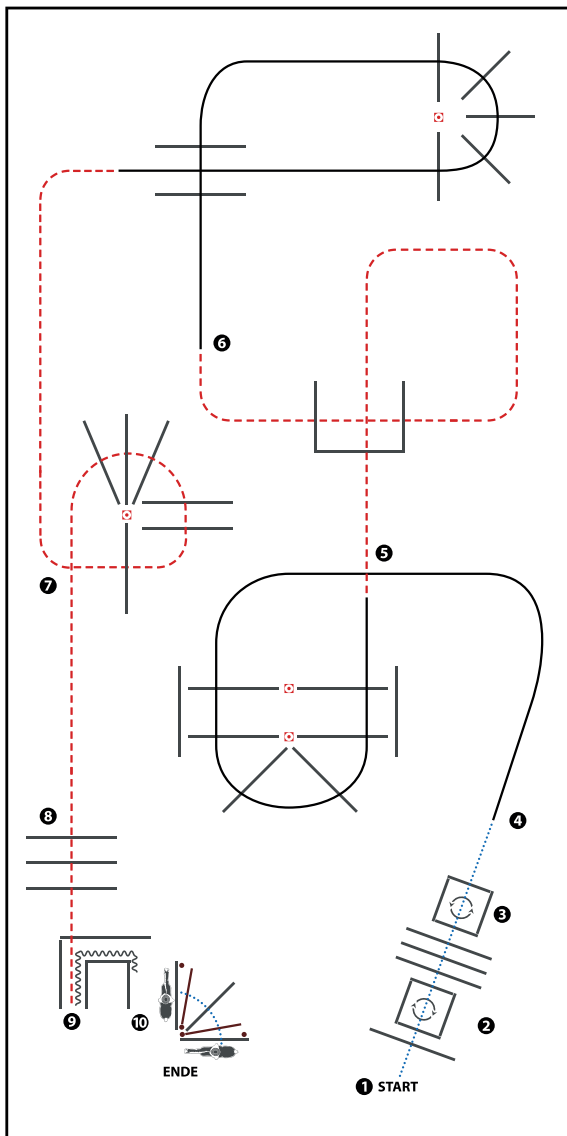

(Erhöhungen optional)

- 1) WALK OVER, INTO BOX, TURN 360° RIGHT
- 2) WALK OUT, WALK OVER
- 3) WALK INTO BOX, TURN 360° LEFT
- 4) LOPE OVER (LL)
- 5) JOG OVER
- 6) LOPE OVER (RL)
- 7) JOG OVER
- 8) JOG OVER
- 9) JOG IN, BACK UP
- 10) GATE RIGHT HAND OPEN, WALK OVER, CLOSE GATE

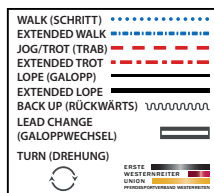

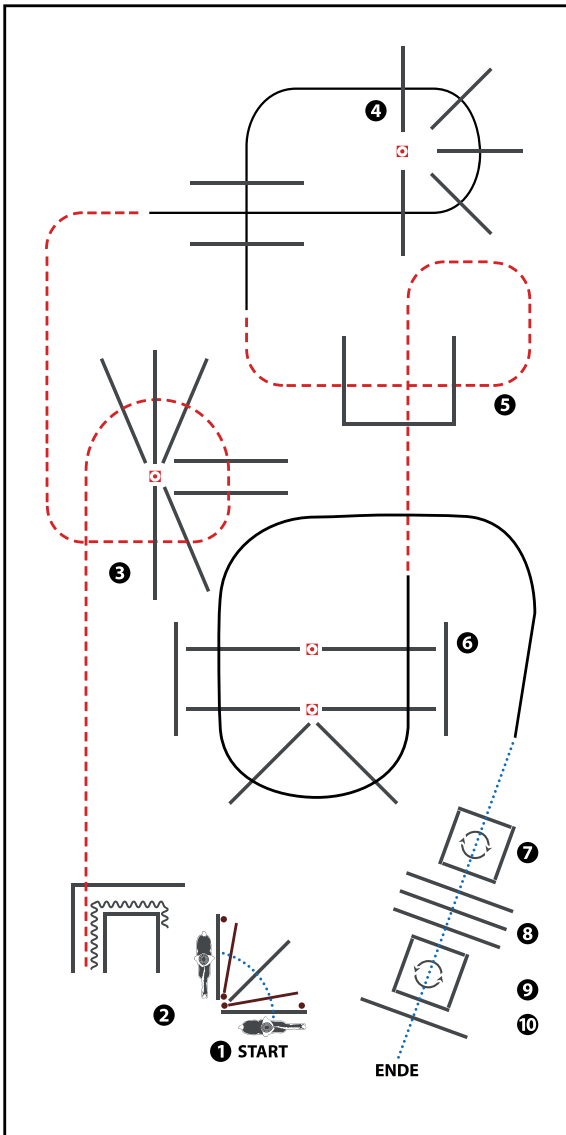

(Erhöhungen optional)

- 1) GATE LEFT HAND OPEN, WALK OVER, CLOSE GATE
- 2) BACK UP, JOG OUT
- 3) JOG OVER
- 4) LOPE OVER (LL)
- 5) JOG OVER
- 6) LOPE OVER (RL)
- 7) WALK INTO BOX, TURN 360° LEFT
- 8) WALK OVER
- 9) WALK INTO BOX, TURN 360° RIGHT
- 10) WALK OUT, WALK OVER

WALK (SCHRITT)	
EXTENDED WALK	
JOG/TROT (TRAB)	
EXTENDED TROT	
LOPE (GALOPP)	
EXTENDED LOPE	
BACK UP (RÜCKWÄRTS)	
LEAD CHANGE (GALOPPWECHSEL)	
TURN (DREHUNG)	
ERSTE	
WESTENREITER	
UNION	
WELDPFERDEBUND SÜDSCHWEIZ	

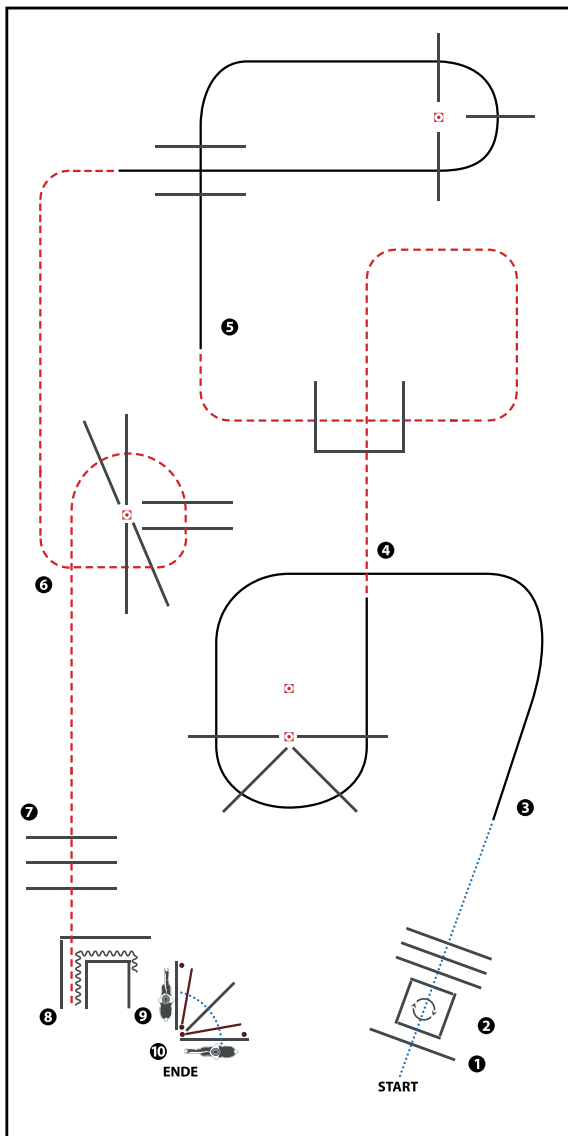

(Erhöhungen optional)

- 1) WALK OVER, INTO BOX,
TURN 360° EITHER WAY (LEFT OR RIGHT)
- 2) WALK OUT, WALK OVER
- 3) LOPE OVER (LL)
- 4) JOG OVER
- 5) LOPE OVER (RL)
- 6) JOG OVER
- 7) JOG OVER
- 8) JOG IN, BACK UP
- 9) GATE RIGHT HAND OPEN, WALK OVER, CLOSE GATE

WALK (SCHRITT)	
EXTENDED WALK	
JOG/TROT (TRAB)	
EXTENDED TROT	
LOPE (GALOPP)	
EXTENDED LOPE	
BACK UP (RÜCKWÄRTS)	
LEAD CHANGE (GALOPPWECHSEL)	
TURN (DREHUNG)	
ERSTE	
WESTENREITER	
UNION	
WELDPFERDEBUND WESTENREITER	

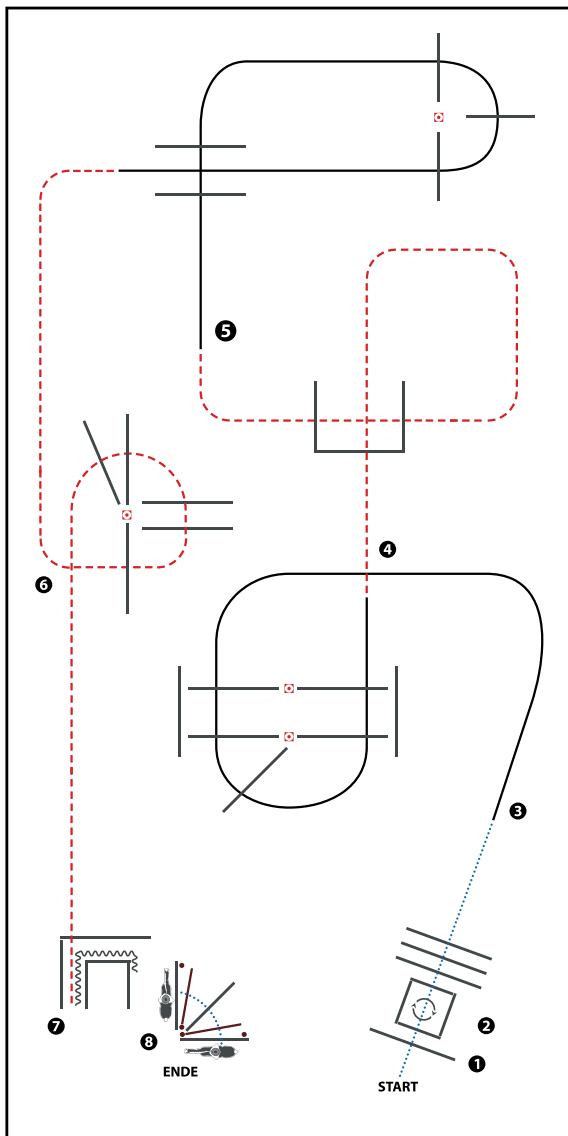

(Erhöhungen optional)

- 1) WALK OVER, INTO BOX,
TURN 360° EITHER WAY (LEFT OR RIGHT)
- 2) WALK OUT, WALK OVER
- 3) LOPE OVER (LL)
- 4) JOG OVER
- 5) LOPE OVER (RL)
- 6) JOG OVER
- 7) JOG IN, BACK UP
- 8) GATE RIGHT HAND OPEN, WALK OVER, CLOSE GATE

WALK (SCHRITT)	
EXTENDED WALK	
JOG/TROT (TRAB)	
EXTENDED TROT	
LOPE (GALOPP)	
EXTENDED LOPE	
BACK UP (RÜCKWÄRTS)	
LEAD CHANGE (GALOPPWECHSEL)	
TURN (DREHUNG)	
ERSTE	
WESTENREITER	
UNION	
WESTENREITER UND WESTENREITER	

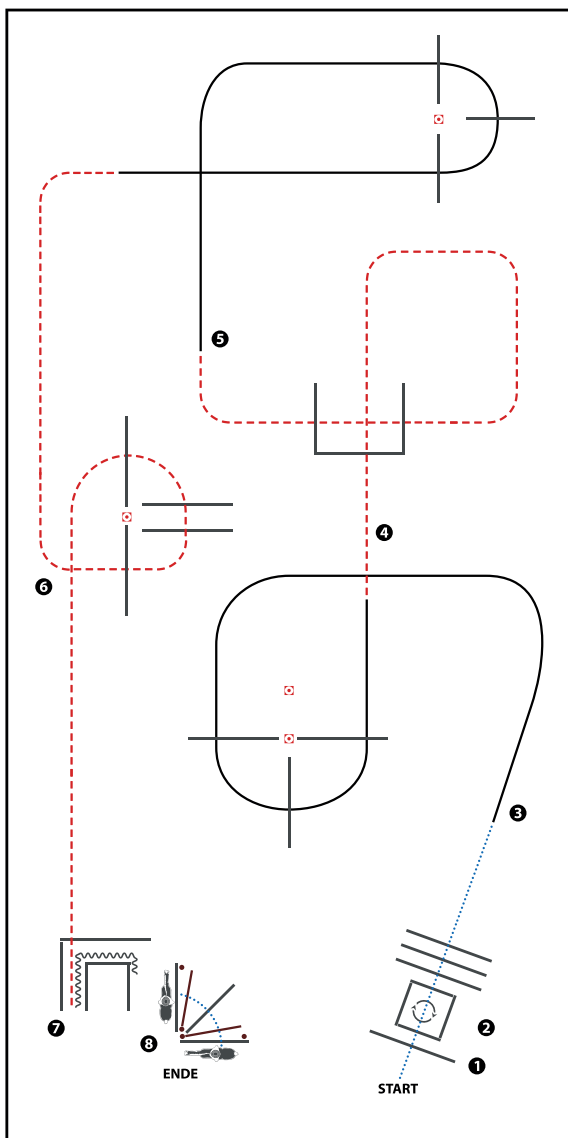

(Erhöhungen optional)

- 1) WALK OVER, INTO BOX,
TURN 360° EITHER WAY (LEFT OR RIGHT)
- 2) WALK OUT, WALK OVER
- 3) LOPE OVER (LL)
- 4) JOG OVER
- 5) LOPE OVER (RL)
- 6) JOG OVER
- 7) JOG IN, BACK UP
- 8) GATE RIGHT HAND

WALK (SCHRITT)	
EXTENDED WALK	
JOG/TROT (TRAB)	
EXTENDED TROT	
LOPE (GALOPP)	
EXTENDED LOPE	
BACK UP (RÜCKWÄRTS)	
LEAD CHANGE (GALOPPWECHSEL)	
TURN (DREHUNG)	
	ERSTE
	WESTERREITER
	UNION
	WELDPFERDEBUND WESTERREICH

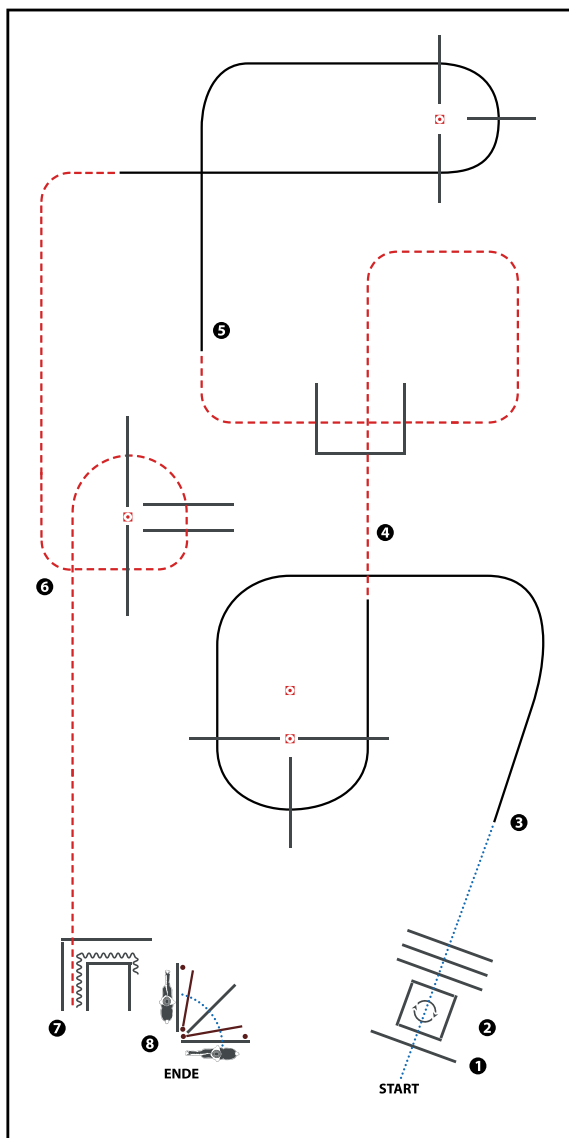

(Erhöhungen optional)

- 1) WALK OVER, INTO BOX,
TURN 360° EITHER WAY (LEFT OR RIGHT)
- 2) WALK OUT, WALK OVER
- 3) LOPE OVER (LL)
- 4) JOG OVER
- 5) LOPE OVER (RL)
- 6) JOG OVER
- 7) JOG IN, BACK UP
- 8) GATE RIGHT HAND

WALK (SCHRITT)	
EXTENDED WALK	
JOG/TROT (TRAB)	
EXTENDED TROT	
LOPE (GALOPP)	
EXTENDED LOPE	
BACK UP (RÜCKWÄRTS)	
LEAD CHANGE (GALOPPWECHSEL)	
TURN (DREHUNG)	
	ERSTE
	WESTENREITER
	UNION
	WELDPFERDEBUND

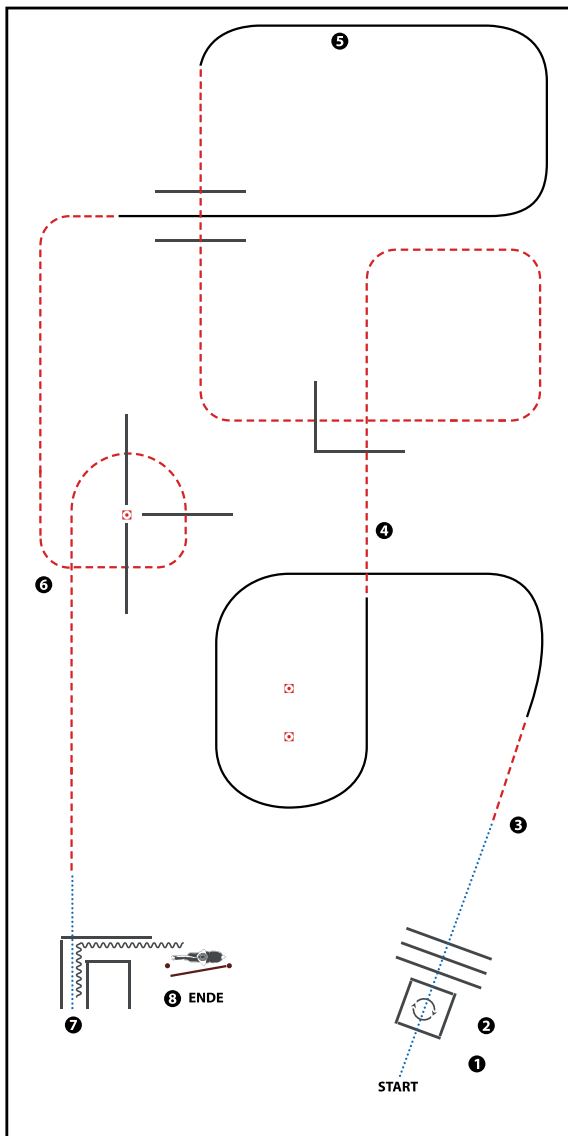

- 1) WALK INTO BOX,
TURN 360° EITHER WAY (LEFT OR RIGHT)
- 2) WALK OUT, WALK OVER
- 3) JOG, LOPE (LL)
- 4) JOG OVER
- 5) LOPE (RL)
- 6) JOG OVER
- 7) WALK IN, BACK UP
- 8) GATE (LEFT HAND)

WALK (SCHRITT)	
EXTENDED WALK	
JOG/TROT (TRAB)	
EXTENDED TROT	
LOPE (GALOPP)	
EXTENDED LOPE	
BACK UP (RÜCKWÄRTS)	
LEAD CHANGE (GALOPPWECHSEL)	
TURN (DREHUNG)	
	ERSTE
	WESTENREITER
	UNION
	WELDPFERDEBUND WELDPFERTEUR

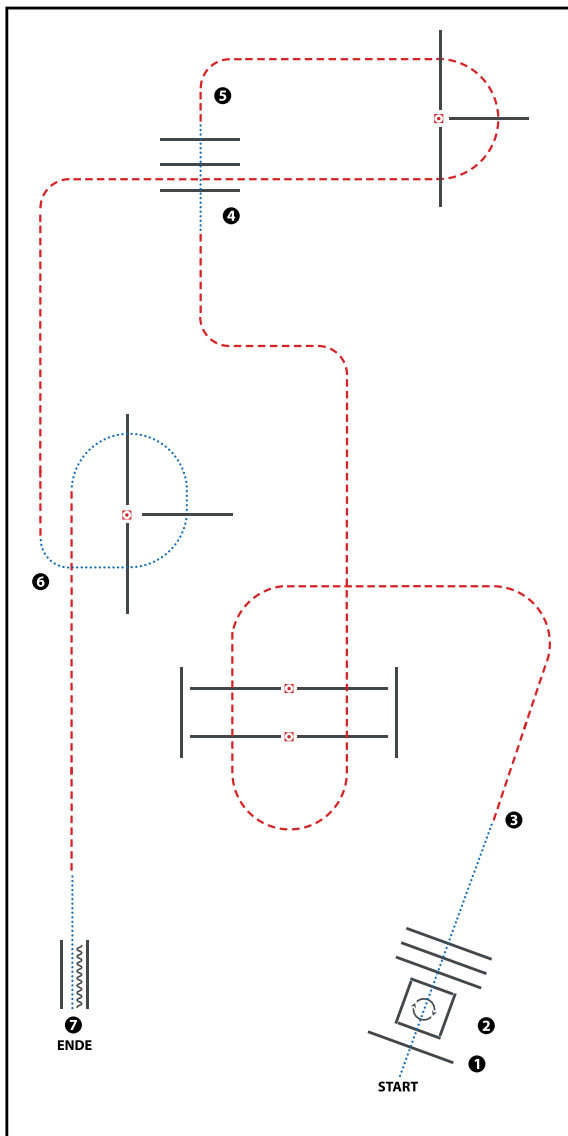

- 1) WALK INTO BOX, TURN 360° EITHER WAY
(im Schritt in die Box, Turn 360° rechts oder links)
- 2) WALK OUT, WALK OVER (Im Schritt aus der Box, Schrittstangen)
- 3) JOG OVER (Trabstangen)
- 4) WALK OVER (Schrittstangen)
- 5) JOG OVER (Trabstangen)
- 6) WALK OVER, JOG (Schrittstangen, Trab)
- 7) WALK IN, BACK UP (im Schritt in die Gasse, Rückwärts)

WALK (SCHRITT)
EXTENDED WALK
JOG/TROT (TRAB)
EXTENDED TROT
LOPE (GALOPP)
EXTENDED LOPE
BACK UP (RÜCKWÄRTS)
LEAD CHANGE (GALOPPWECHSEL)
TURN (DREHUNG)
ERSTE
WESTENREITER
UNION
WELDPFERDEBUND WESTENREITER

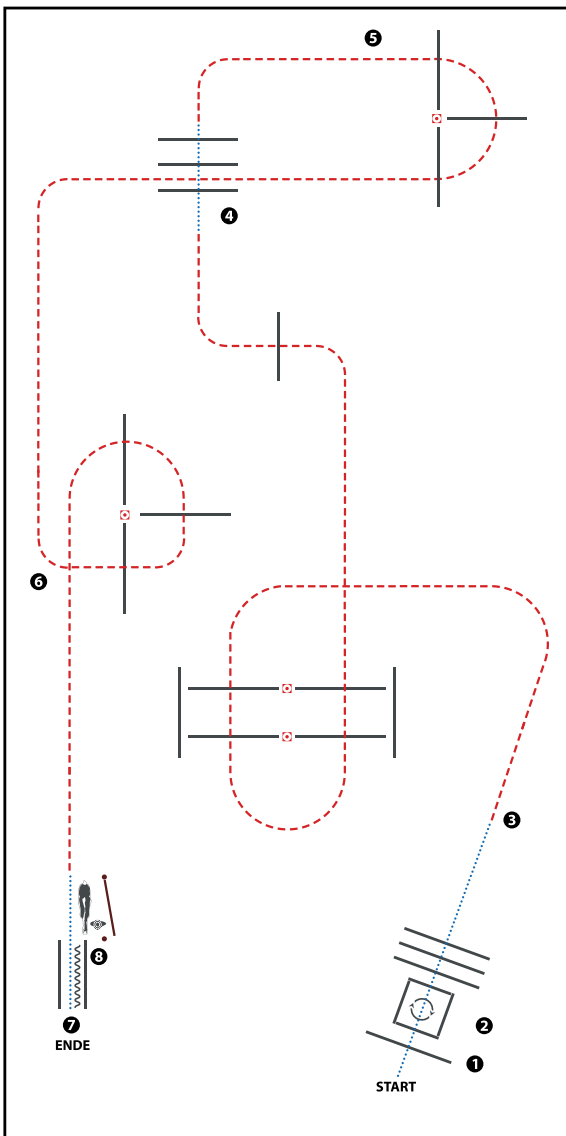

- 1) WALK OVER, INTO BOX,
TURN 360° EITHER WAY (LEFT OR RIGHT)
- 2) WALK OUT, WALK OVER
- 3) JOG OVER
- 4) WALK OVER
- 5) JOG OVER
- 6) JOG OVER
- 7) WALK IN, BACK UP
- 8) GATE (LEFT HAND)

WALK (SCHRITT)	
EXTENDED WALK	
JOG/TROT (TRAB)	
EXTENDED TROT	
LOPE (GALOPP)	
EXTENDED LOPE	
BACK UP (RÜCKWÄRTS)	
LEAD CHANGE (GALOPPWECHSEL)	
TURN (DREHUNG)	
	ERSTE
	WESTENREITER
	UNION
	WELDPFERDEBUND WESTENREITER

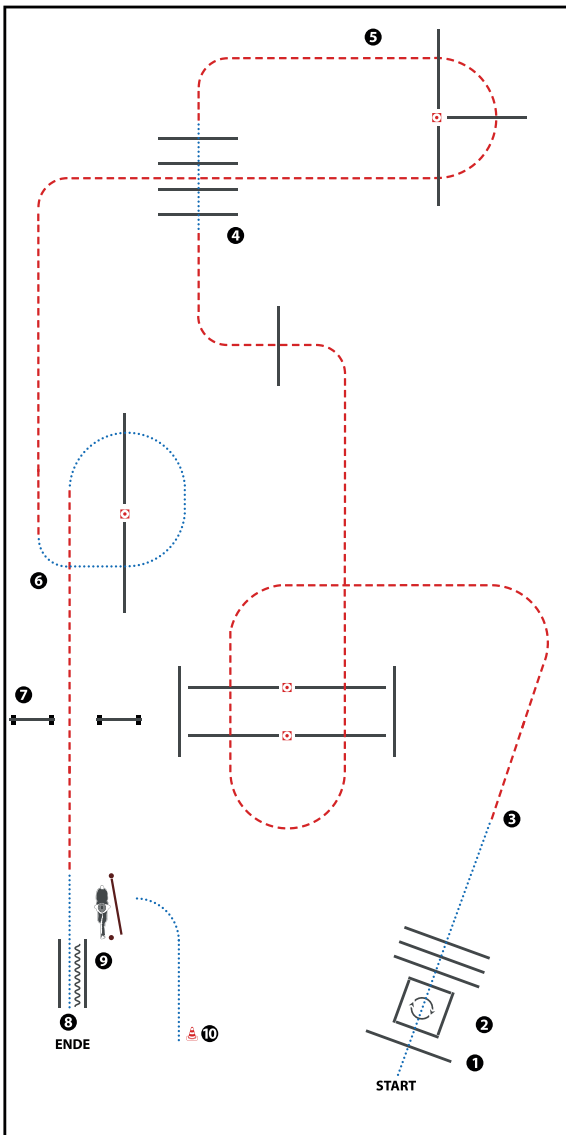

HUND ABLEINEN

- 1) HUND IN BOX ABLEGEN, WALK INTO BOX, TURN 360° EITHER WAY (LEFT OR RIGHT)
- 2) HUND IN BOX WALK OUT, WALK OVER
- 3) HUND BEI FUSS JOG OVER
- 4) HUND BEI FUSS WALK OVER
- 5) HUND BEI FUSS, HUND DURCH GASSE (RIGHT OR LEFT), JOG
- 6) HUND BEI FUSS WALK OVER
- 7) HUND SPRUNG, JOG
- 8) HUND ABLEGEN, WALK IN, BACK UP
- 9) GATE (LEFT HAND)
- 10) HUND ABRUFEN, WALK, ANLEINEN

WALK (SCHRITT)
EXTENDED WALK	-----
JOG/TROT (TRAB)	-----
EXTENDED TROT	-----
LOPE (GALOPP)	-----
EXTENDED LOPE	-----
BACK UP (RÜCKWÄRTS)	~~~~~
LEAD CHANGE (GALOPPWECHSEL)	=====
TURN (DREHUNG)	
ERSTE	
WESTENREITER	
UNION	
WESTENREITER	

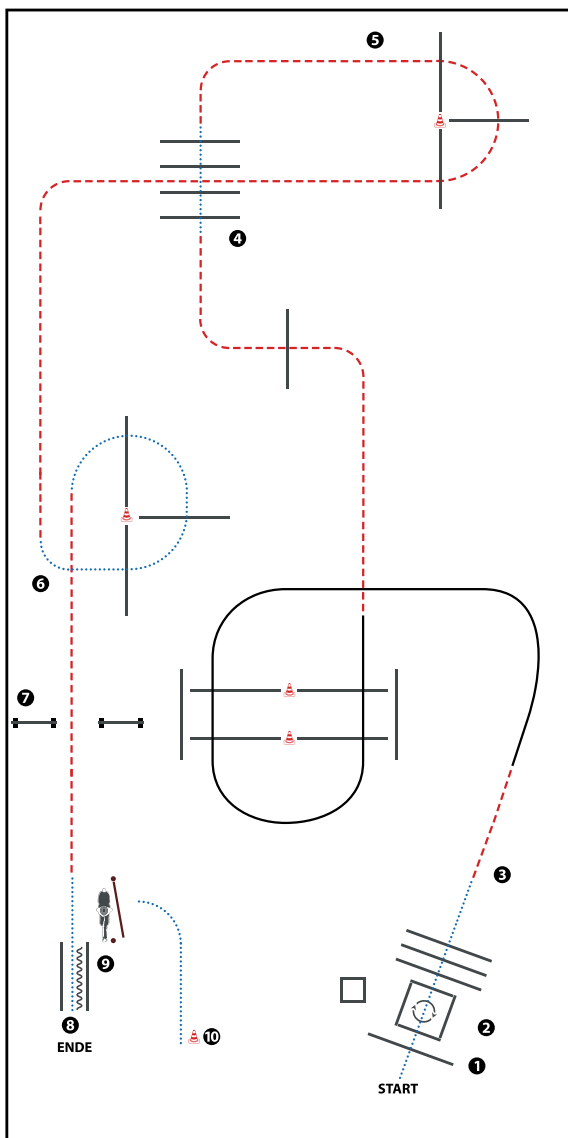

HUND ABLEINEN

- 1) HUND IN BOX ABLEGEN, WALK INTO BOX, TURN 360° EITHER WAY (LEFT OR RIGHT)
- 2) HUND IN BOX WALK OUT, WALK OVER
- 3) HUND BEI FUSS LOPE OVER, JOG
- 4) HUND BEI FUSS WALK OVER
- 5) HUND BEI FUSS, HUND DURCH GASSE (RIGHT OR LEFT), JOG OVER
- 6) HUND BEI FUSS WALK OVER
- 7) HUND SPRUNG, JOG
- 8) HUND ABLEGEN, WALK IN, BACK UP
- 9) GATE (LEFT HAND)
- 10) HUND ABRUFEN, WALK, ANLEINEN

WALK (SCHRITT)
EXTENDED WALK
JOG/TROT (TRAB)
EXTENDED TROT
LOPE (GALOPP)
EXTENDED LOPE
BACK UP (RÜCKWÄRTS)
LEAD CHANGE (GALOPPWECHSEL)
TURN (DREHUNG)
ERSTE
WESTERREITER
UNION
WELDPFERDEBUND WESTERREICH

Trail Set 13

Pattern 1-11

Arenagröße mind. 25 x 50 m

Für TH-Pattern gelten folgende Abstände und Maße:

WALK / WALK OVER	Abstand 40 - 60 cm • Erhöhung max. 30 cm. Bei Erhöhung sollte der Mindestabstand 55 cm betragen.
JOG / JOG OVER	Abstand 90 - 105 cm • Erhöhung max. 20 cm.
EXTENDED JOG	Abstand 105 - 125 cm.
LOPE / LOPE OVER	Abstand 180 - 210 cm • Erhöhung max. 20 cm.
EXTENDED LOPE	Abstand 210 - 225 cm.
BACK UP	Abstandmind. 100 cm, Erhöhung max. 30 cm.
SIDEPASS	Abstand in einer Gasse mind. 200 cm (ganzes Pferd), mind. 60 cm (1 Beinpaar zwischen zwei Stangen), Erhöhung max. 30 cm.
SERPENTIN WALK	Abstand mind. 200 cm
SERPENTIN JOG	Abstand mind. 250 cm
GATE	Breite mind. 90 cm, Länge 250 cm,
BRIDGE	Breite mind. 150 cm, Länge 250 cm,
BRIDGE WITH RAILING	Breite mind. 150 cm, Länge 250 cm,
BOX	Abstand 180 - 210 cm
JUMP	Erhöhung max. 45 cm

Zwischen den Hindernissen sollte eine:

Trabstrecke von mind. 10,00 m

Galoppstrecke von mind. 20,00 m

Volten sollten für Reiter der LK 5 und 4 nicht weniger als 12,00 m Durchmesser,
für LK 1 bis 3 nicht weniger als 10,00 m betragen

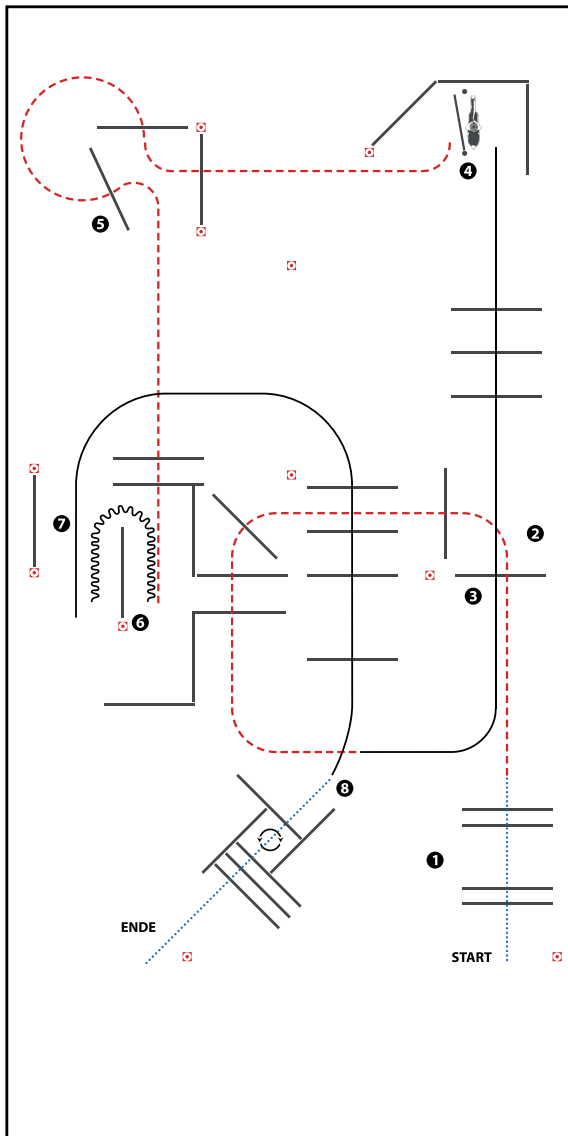

(Erhöhungen optional)

- 1) WALK OVER
- 2) JOG OVER
- 3) LOPE OVER (LL)
- 4) GATE
- 5) JOG OVER, JOG INTO CHUTE
- 6) BACK UP
- 7) LOPE OUT, LOPE OVER (RL)
- 8) STOP OR BREAK TO WALK, WALK INTO BOX, 360° TURN EITHER WAY (LEFT OR RIGHT), WALK OVER

WALK (SCHRITT)	
EXTENDED WALK	
JOG/TROT (TRAB)	
EXTENDED TROT	
LOPE (GALOPP)	
EXTENDED LOPE	
BACK UP (RÜCKWÄRTS)	
LEAD CHANGE (GALOPPWECHSEL)	
TURN (DREHUNG)	
	ERSTE
	WESTENREITER
	UNION
	WORLDSPORTFEDERATION

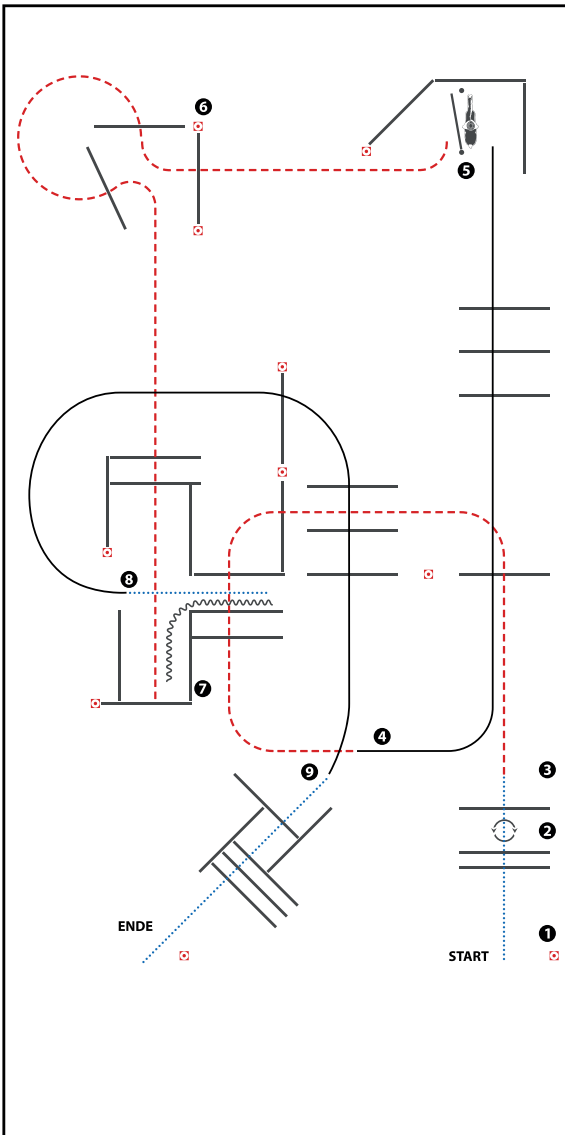

(Erhöhungen optional)

- 1) WALK OVER
- 2) STOP BETWEEN POLES, 360° TURN
EITHER WAY (LEFT OR RIGHT), WALK OVER
- 3) JOG OVER
- 4) LOPE OVER (LL)
- 5) GATE
- 6) JOG OVER, JOG INTO CHUTE
- 7) BACK UP
- 8) WALK OUT, LOPE OVER (RL)
- 9) STOP OR BREAK TO WALK, WALK OVER

WALK (SCHRITT)	
EXTENDED WALK	
JOG/TROT (TRAB)	
EXTENDED TROT	
LOPE (GALOPP)	
EXTENDED LOPE	
BACK UP (RÜCKWÄRTS)	
LEAD CHANGE (GALOPPWECHSEL)	
TURN (DREHUNG)	
	ERSTE
	WESTENREITER
	UNION
	WELDPFERDEBUND WESTENREITER

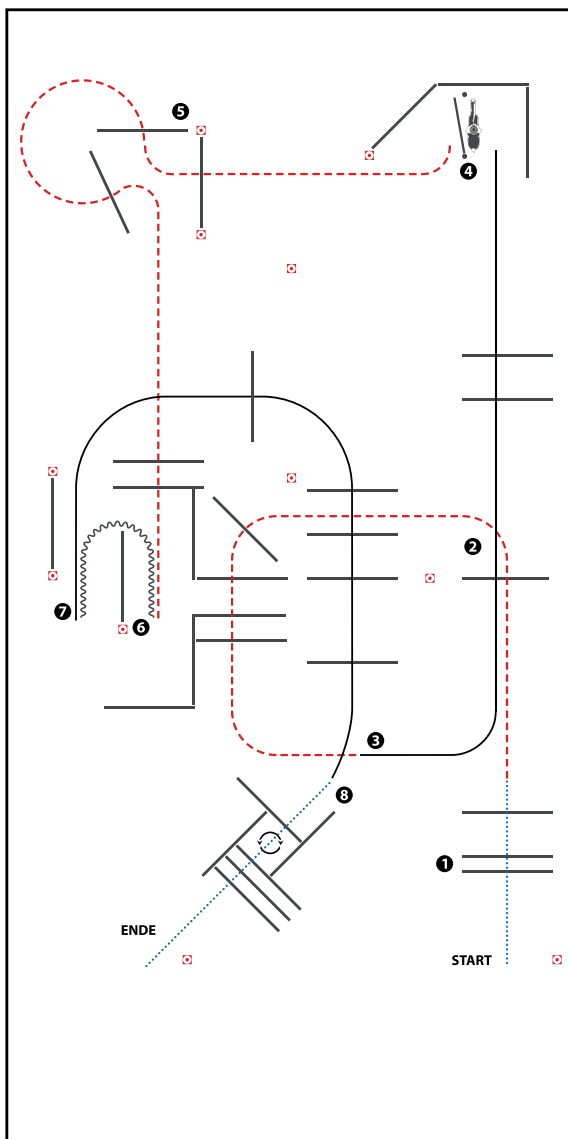

(Erhöhungen optional)

- 1) WALK OVER
- 2) JOG OVER
- 3) LOPE OVER (LL)
- 4) GATE
- 5) JOG OVER, JOG INTO CHUTE
- 6) BACK UP
- 7) LOPE OUT, LOPE OVER (RL)
- 8) STOP OR BREAK TO WALK, WALK INTO BOX, 360° TURN EITHER WAY (LEFT OR RIGHT), WALK OVER

WALK (SCHRITT)
EXTENDED WALK
JOG/TROT (TRAB)
EXTENDED TROT
LOPE (GALOPP)
EXTENDED LOPE
BACK UP (RÜCKWÄRTS)
LEAD CHANGE (GALOPPWECHSEL)
TURN (DREHUNG)
ERSTE
WESTENREITER
UNION
WELDPFERDEBUND WESTENREITER

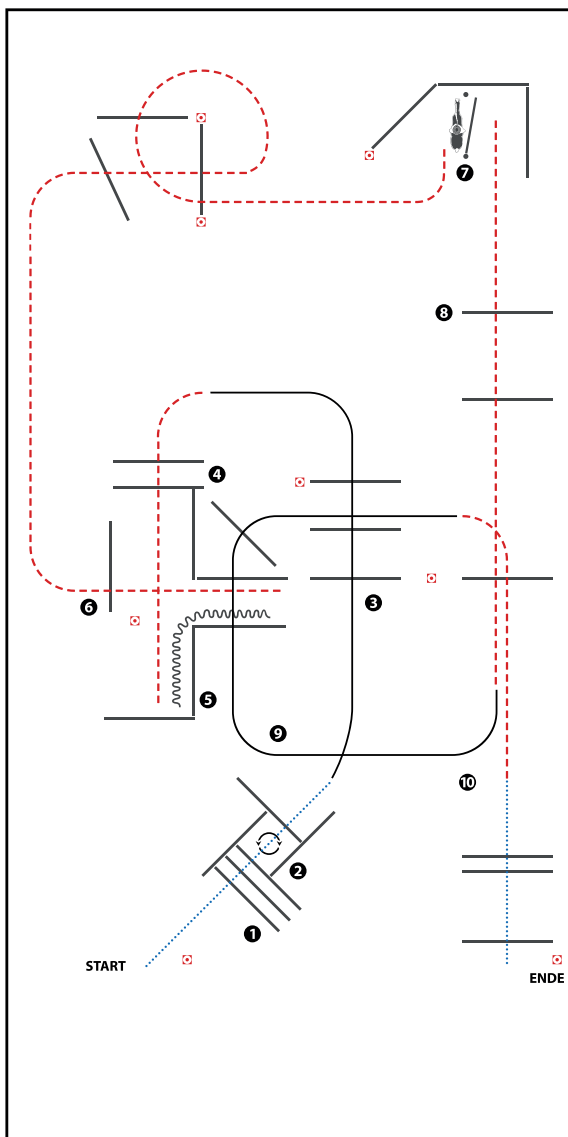

(Erhöhungen optional)

- 1) WALK OVER, WALK INTO BOX
- 2) 360° TURN EITHER WAY (LEFT OR RIGHT), WALK OUT
- 3) LOPE OVER (LL)
- 4) JOG OVER
- 5) BACK UP
- 6) JOG OUT, JOG OVER
- 7) GATE
- 8) JOG OVER
- 9) LOPE OVER (RL), JOG OVER
- 10) STOP OR BREAK TO WALK, WALK OVER

WALK (SCHRITT)
EXTENDED WALK
JOG/TROT (TRAB)	-----
EXTENDED TROT
LOPE (GALOPP)	=====
EXTENDED LOPE	-----
BACK UP (RÜCKWÄRTS)	~~~~~
LEAD CHANGE (GALOPPWECHSEL)	=====
TURN (DREHUNG)	
	ERSTE
	WESTENREITER
	UNION
	WIRTSCHAFTSUNIVERSITÄT SACHSSEN

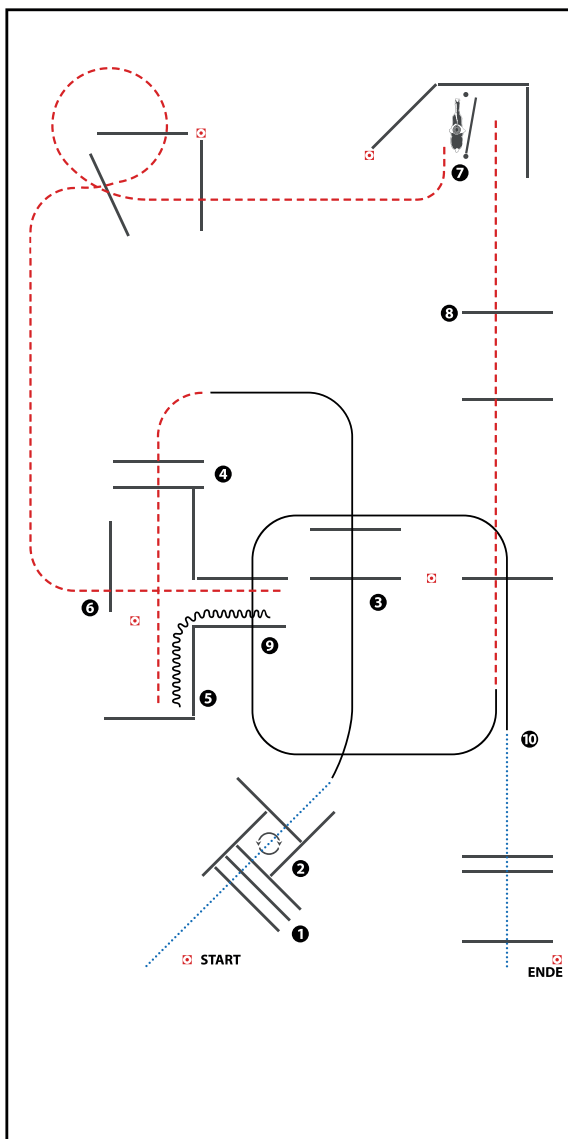

(Erhöhungen optional)

- 1) WALK OVER, WALK INTO BOX
- 2) 360° TURN EITHER WAY (LEFT OR RIGHT), WALK OUT
- 3) LOPE OVER (LL)
- 4) JOG OVER
- 5) BACK UP
- 6) JOG OUT, JOG OVER
- 7) GATE
- 8) JOG OVER
- 9) LOPE OVER (RL)
- 10) STOP OR BREAK TO WALK, WALK OVER

WALK (SCHRITT)	
EXTENDED WALK	
JOG/TROT (TRAB)	
EXTENDED TROT	
LOPE (GALOPP)	
EXTENDED LOPE	
BACK UP (RÜCKWÄRTS)	
LEAD CHANGE (GALOPPWECHSEL)	
TURN (DREHUNG)	
	ERSTE
	WEITERER
	UNION
	WIEDERHOLER

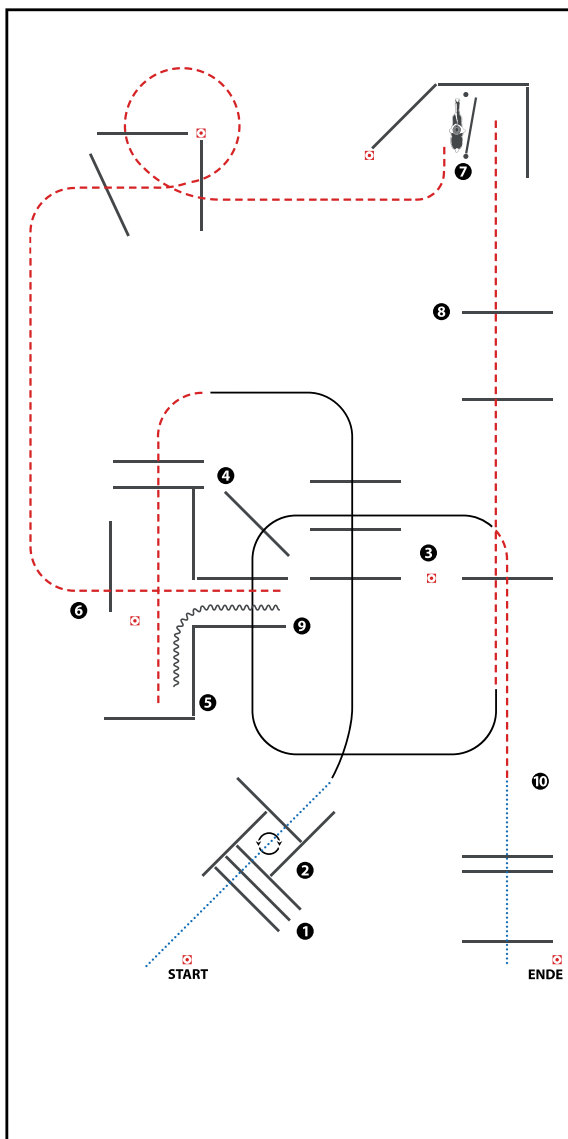

(Erhöhungen optional)

- 1) WALK OVER, WALK INTO BOX
- 2) 360° TURN EITHER WAY (LEFT OR RIGHT), WALK OUT
- 3) LOPE OVER (LL)
- 4) JOG OVER
- 5) BACK UP
- 6) JOG OUT, JOG OVER
- 7) GATE
- 8) JOG OVER
- 9) LOPE OVER (RL), JOG OVER
- 10) STOP OR BREAK TO WALK, WALK OVER

WALK (SCHRITT)	
EXTENDED WALK	
JOG/TROT (TRAB)	
EXTENDED TROT	
LOPE (GALOPP)	
EXTENDED LOPE	
BACK UP (RÜCKWÄRTS)	
LEAD CHANGE (GALOPPWECHSEL)	
TURN (DREHUNG)	
	ERSTE
	WESTENREITER
	UNION
	WIRTSCHAFTSUNIVERSITÄT SIEGEN

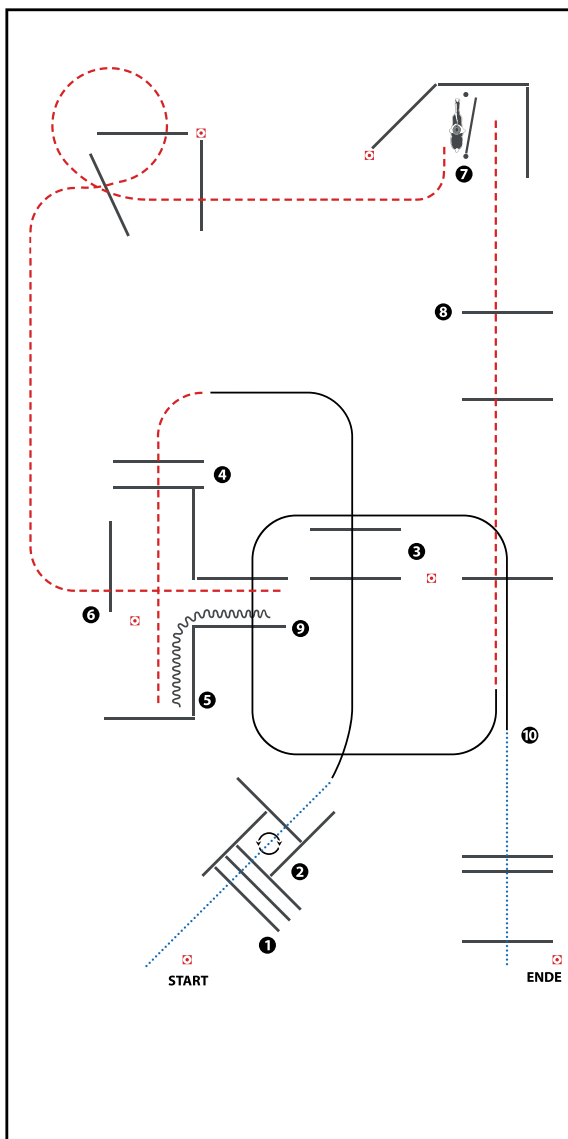

(Erhöhungen optional)

- 1) WALK OVER, WALK INTO BOX
- 2) 360° TURN EITHER WAY (LEFT OR RIGHT), WALK OUT
- 3) LOPE OVER (LL)
- 4) JOG OVER
- 5) BACK UP
- 6) JOG OUT, JOG OVER
- 7) GATE
- 8) JOG OVER
- 9) LOPE OVER (RL)
- 10) STOP OR BREAK TO WALK, WALK OVER

WALK (SCHRITT)	
EXTENDED WALK	
JOG/TROT (TRAB)	
EXTENDED TROT	
LOPE (GALOPP)	
EXTENDED LOPE	
BACK UP (RÜCKWÄRTS)	
LEAD CHANGE (GALOPPWECHSEL)	
TURN (DREHUNG)	
ERSTE	
WESTERWEITER	
UNION	
WIEDERHOLER/ERNEUER WESTERWEITER	

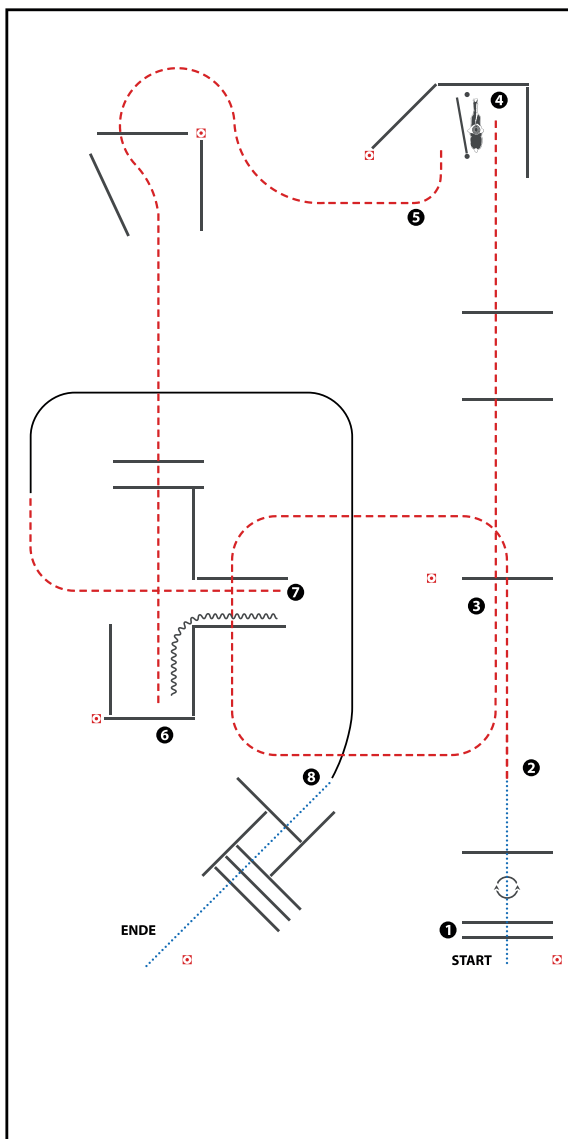

(Erhöhungen optional)

- 1) WALK OVER, STOP BETWEEN POLES,
360° TURN EITHER WAY (LEFT OR RIGHT), WALK OVER
- 2) JOG OVER
- 3) JOG OVER
- 4) GATE
- 5) JOG OVER, JOG INTO CHUTE
- 6) BACK UP
- 7) JOG OUT, LOPE (RL)
- 8) STOP OR BREAK TO WALK, WALK OVER

WALK (SCHRITT)
EXTENDED WALK
JOG/TROT (TRAB)	-----
EXTENDED TROT	-----
LOPE (GALOPP)	=====
EXTENDED LOPE	=====
BACK UP (RÜCKWÄRTS)	~~~~~
LEAD CHANGE (GALOPPWECHSEL)	=====
TURN (DREHUNG)	⊙
	ERSTE WESTERWEITER
	UNION WELDFISCHERBERG WELDFISCHER

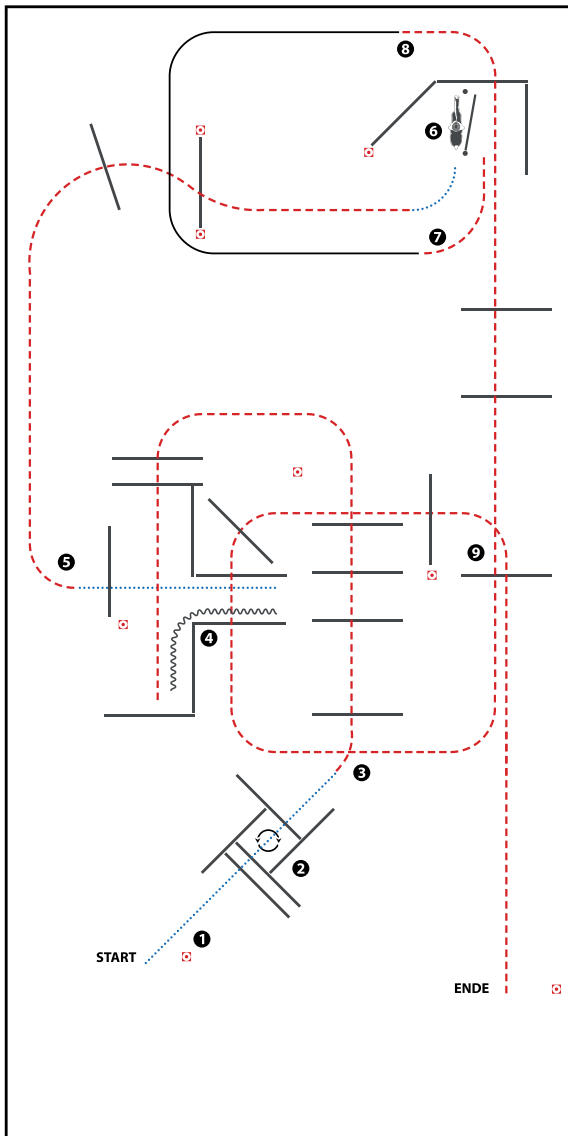

- 1) WALK OVER, WALK INTO BOX
- 2) 360° TURN EITHER WAY (LEFT OR RIGHT), WALK OUT
- 3) JOG OVER
- 4) BACK UP, WALK OUT, WALK OVER
- 5) JOG OVER, WALK
- 6) GATE
- 7) JOG, LOPE (RL)
- 8) JOG OVER
- 9) JOG OVER

WALK (SCHRITT)
EXTENDED WALK
JOG/TROT (TRAB)
EXTENDED TROT
LOPE (GALOPP)
EXTENDED LOPE
BACK UP (RÜCKWÄRTS)	~~~~~
LEAD CHANGE (GALOPPWECHSEL)	=====
TURN (DREHUNG)	⤵
ERSTE	=====
WESTERWEITER	=====
UNION	=====
WELDFORP/GERÄTE/WECHSELHILFE	=====

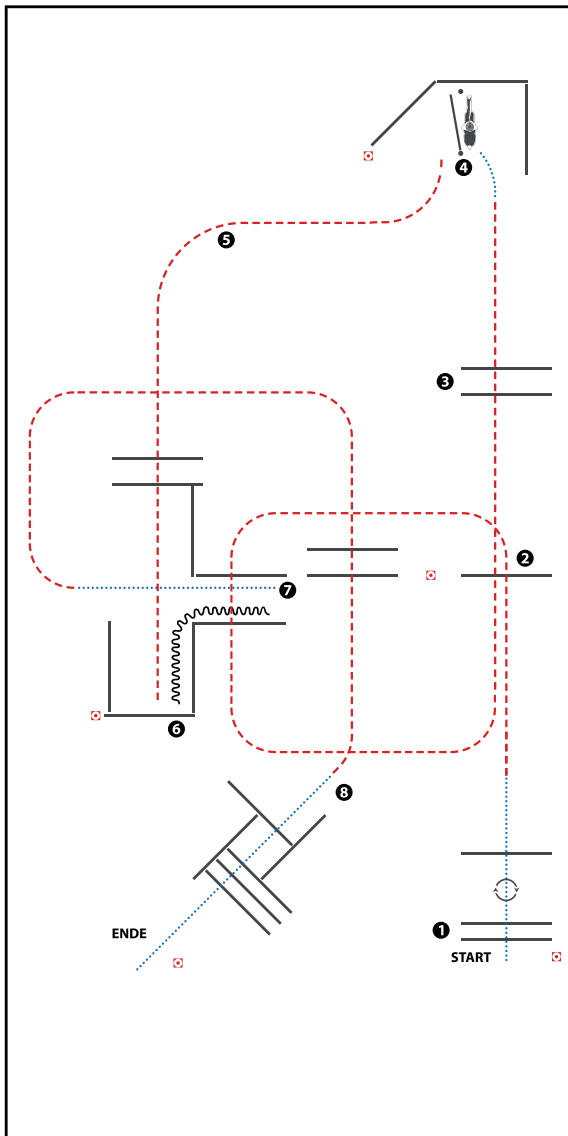

(Tor optional)

- 1) WALK OVER, STOP BETWEEN POLES, 360° TURN RIGHT, WALK OVER (Schrittstangen, Anhalten zwischen den Stangen, 360° Wendung rechts, Schrittstange)
- 2) JOG OVER (Trabstangen)
- 3) JOG OVER, WALK (Trabstangen, Schritt)
- 4) GATE (Tor)
- 5) JOG OVER, JOG INTO CHUTE (Trabstangen, Trab in die Gasse)
- 6) BACK UP (Rückwärts)
- 7) WALK OUT, JOG OVER (im Schritt aus der Gasse, Trabstangen)
- 8) STOP OR BREAK TO WALK, WALK OVER (Anhalten oder Übergang zum Schritt, Schrittstangen)

WALK (SCHRITT)
EXTENDED WALK
JOG/TROT (TRAB)	-----
EXTENDED TROT	-----
LOPE (GALOPP)	=====
EXTENDED LOPE	=====
BACK UP (RÜCKWÄRTS)	~~~~~
LEAD CHANGE (GALOPPWECHSEL)	=====
TURN (DREHUNG)	⊙
	ERSTE WESTENWEITER UNION WIEDERHERSTELLUNG

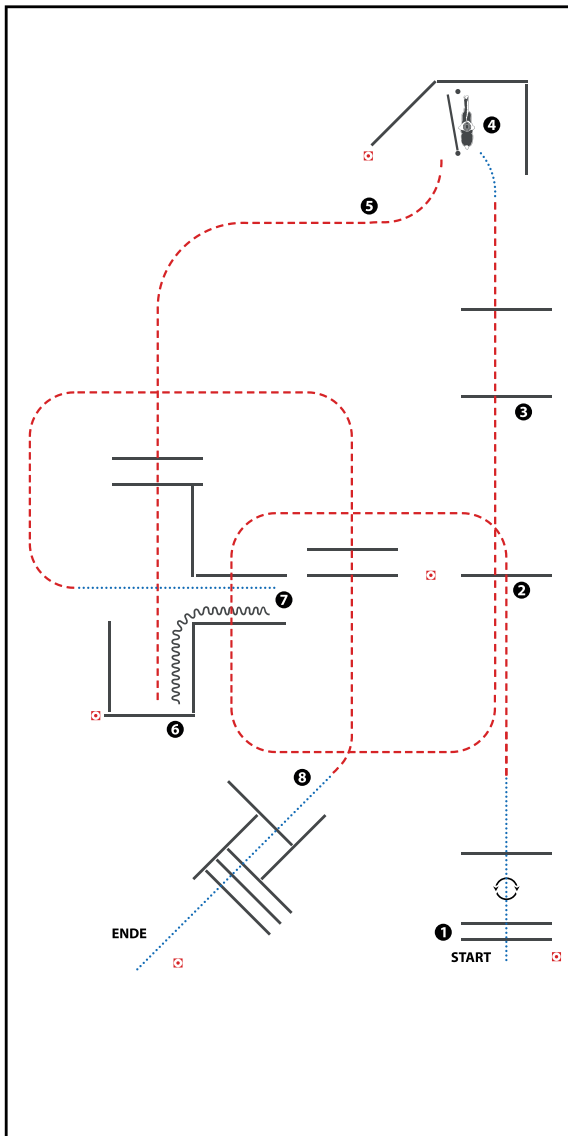

- 1) WALK OVER, STOP BETWEEN POLES, 360° TURN RIGHT, WALK OVER
- 2) JOG OVER
- 3) JOG OVER, WALK
- 4) GATE
- 5) JOG OVER, JOG INTO CHUTE
- 6) BACK UP
- 7) WALK OUT, JOG OVER
- 8) STOP OR BREAK TO WALK, WALK OVER

WALK (SCHRITT)
EXTENDED WALK
JOG/TROT (TRAB)	-----
EXTENDED TROT
LOPE (GALOPP)	=====
EXTENDED LOPE	=====
BACK UP (RÜCKWÄRTS)	~~~~~
LEAD CHANGE (GALOPPWECHSEL)	=====
TURN (DREHUNG)	⤵
	ERSTE WESTENREITER
	UNION WESTENREITER
	WESTENREITER WESTENREITER

Trail Set 14

Pattern 1-8

Arenagröße mind. 25 x 50 m

Für TH-Pattern gelten folgende Abstände und Maße:

WALK / WALK OVER	Abstand 40 - 60 cm • Erhöhung max. 30 cm. Bei Erhöhung sollte der Mindestabstand 55 cm betragen.
JOG / JOG OVER	Abstand 90 - 105 cm • Erhöhung max. 20 cm.
EXTENDED JOG	Abstand 105 - 125 cm.
LOPE / LOPE OVER	Abstand 180 - 210 cm • Erhöhung max. 20 cm.
EXTENDED LOPE	Abstand 210 - 225 cm.
BACK UP	Abstandmind. 100 cm, Erhöhung max. 30 cm.
SIDEPASS	Abstand in einer Gasse mind. 200 cm (ganzes Pferd), mind. 60 cm (1 Beinpaar zwischen zwei Stangen), Erhöhung max. 30 cm.
SERPENTIN WALK	Abstand mind. 200 cm
SERPENTIN JOG	Abstand mind. 250 cm
GATE	Breite mind. 90 cm, Länge 250 cm,
BRIDGE	Breite mind. 150 cm, Länge 250 cm,
BRIDGE WITH RAILING	Breite mind. 150 cm, Länge 250 cm,
BOX	Abstand 180 - 210 cm
JUMP	Erhöhung max. 45 cm

Zwischen den Hindernissen sollte eine:

Trabstrecke von mind. 10,00 m

Galoppstrecke von mind. 20,00 m

Volten sollten für Reiter der LK 5 und 4 nicht weniger als 12,00 m Durchmesser,
für LK 1 bis 3 nicht weniger als 10,00 m betragen

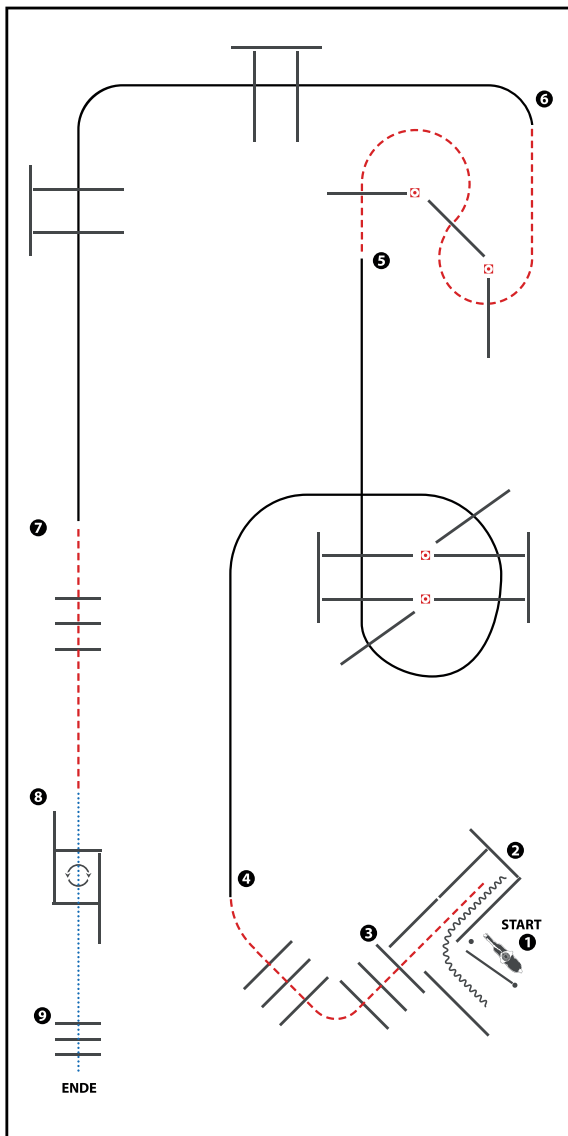

(Erhöhungen optional)

- 1) GATE LH
- 2) BACK UP, JOG OUT
- 3) JOG OVER
- 4) LOPE OVER (RL)
- 5) JOG OVER
- 6) LOPE OVER (LL)
- 7) JOG OVER
- 8) WALK INTO BOX, 360° TURN EITHER WAY (LEFT OR RIGHT), WALK OUT
- 9) WALK OVER

WALK (SCHRITT)
EXTENDED WALK
JOG/TROT (TRAB)	-----
EXTENDED TROT	-----
LOPE (GALOPP)	=====
EXTENDED LOPE	=====
BACK UP (RÜCKWÄRTS)	~~~~~
LEAD CHANGE (GALOPPWECHSEL)	=====
TURN (DREHUNG)	
	ERSTE
	WESTENREITER
	UNION
	WELDFÖRDERNDE VERBÄNDER

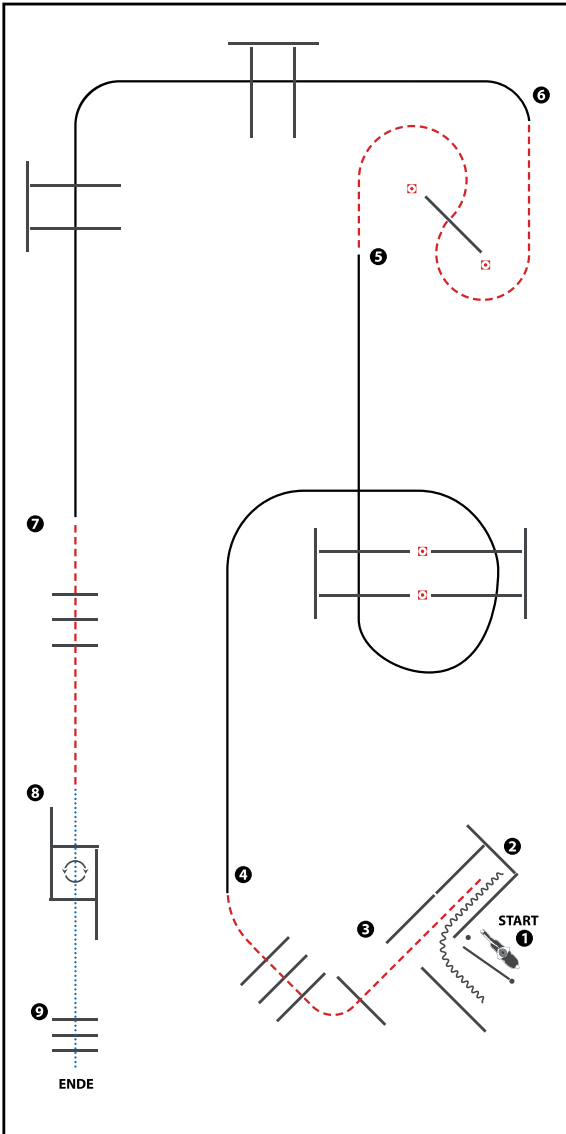

(Erhöhungen optional)

(Erhöhungen optional)

- 1) GATE LH
- 2) BACK UP, JOG OUT
- 3) JOG OVER
- 4) LOPE OVER (RL)
- 5) JOG OVER
- 6) LOPE OVER (LL)
- 7) JOG OVER
- 8) WALK INTO BOX, 360° TURN EITHER WAY (LEFT OR RIGHT), WALK OUT
- 9) WALK OVER

WALK (SCHRITT)
EXTENDED WALK
JOG/TROT (TRAB)
EXTENDED TROT
LOPE (GALOPP)
EXTENDED LOPE
BACK UP (RÜCKWÄRTS)
LEAD CHANGE (GALOPPWECHSEL)
TURN (DREHUNG)
ERSTE
WESTENREITER
UNION
WESTENREITER

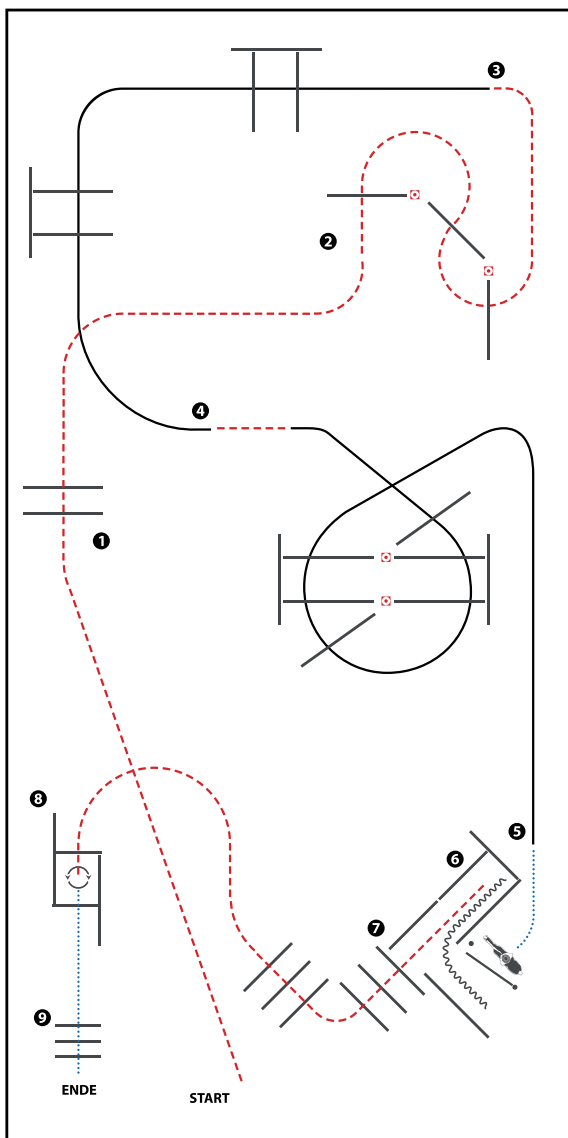

(Erhöhungen optional)

- 1) JOG OVER
- 2) JOG OVER
- 3) LOPE OVER (LL)
- 4) JOG, LOPE OVER (RL)
- 5) WALK, GATE
- 6) BACK UP, JOG OUT
- 7) JOG OVER
- 8) JOG INTO BOX, 360° TURN EITHER WAY (LEFT OR RIGHT), WALK OUT
- 9) WALK OVER

WALK (SCHRITT)	
EXTENDED WALK	
JOG/TROT (TRAB)	
EXTENDED TROT	
LOPE (GALOPP)	
EXTENDED LOPE	
BACK UP (RÜCKWÄRTS)	
LEAD CHANGE (GALOPPWECHSEL)	
TURN (DREHUNG)	
	ERSTE
	WESTENREITER
	UNION
	WESTENREITER

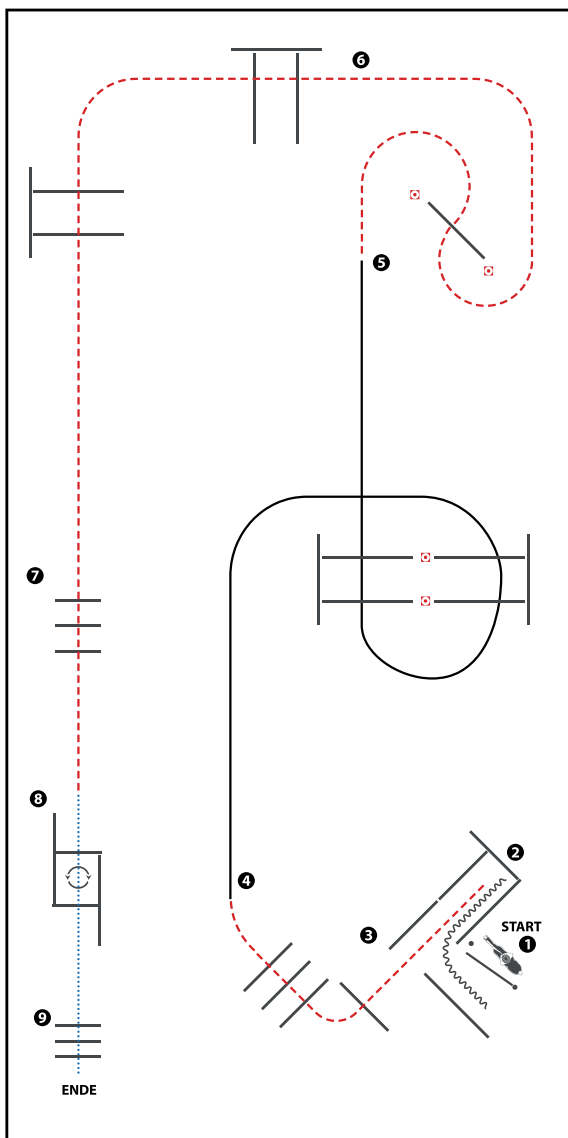

(Erhöhungen optional)

- 1) GATE LH
- 2) BACK UP, JOG OUT
- 3) JOG OVER
- 4) LOPE OVER (RL)
- 5) JOG OVER
- 6) JOG OVER
- 7) JOG OVER
- 8) WALK INTO BOX, 360° TURN EITHER WAY (LEFT OR RIGHT), WALK OUT
- 9) WALK OVER

WALK (SCHRITT)
EXTENDED WALK
JOG/TROT (TRAB)	-----
EXTENDED TROT	-----
LOPE (GALOPP)	=====
EXTENDED LOPE	=====
BACK UP (RÜCKWÄRTS)	~~~~~
LEAD CHANGE (GALOPPWECHSEL)	=====
TURN (DREHUNG)	
ERSTE	
WESTENREITER	
UNION	
WESTENREITER	

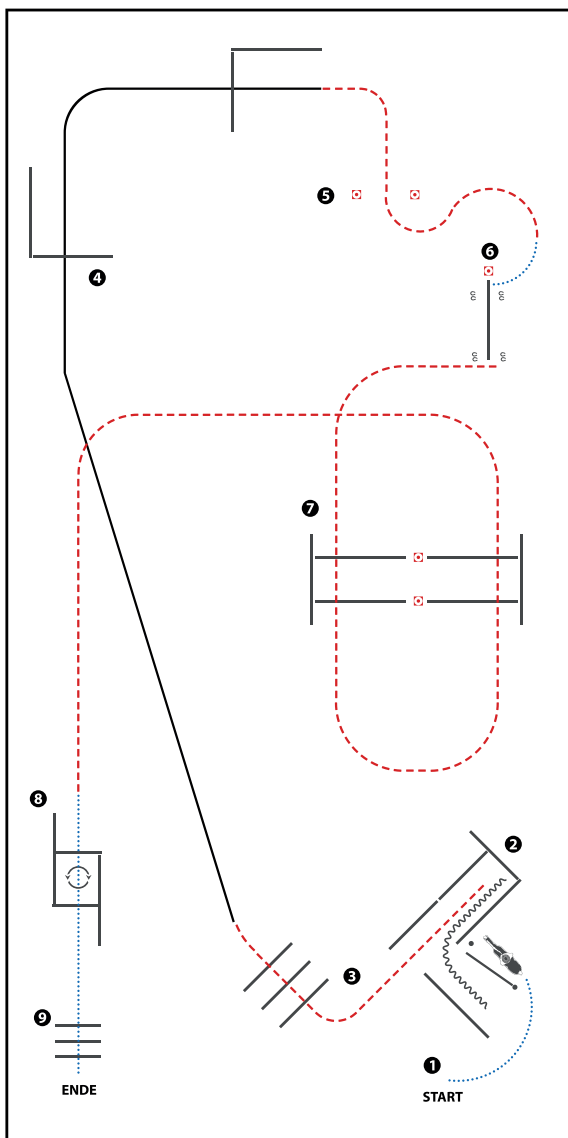

(Erhöhungen optional)

- 1) WALK, GATE
- 2) BACK UP, JOG OUT
- 3) JOG OVER
- 4) LOPE OVER (RL)
- 5) JOG THRU MARKER
- 6) WALK, SIDEPASS LEFT
- 7) JOG OVER
- 8) WALK INTO BOX, 360° TURN EITHER WAY (LEFT OR RIGHT), WALK OUT
- 9) WALK OVER

WALK (SCHRITT)
EXTENDED WALK
JOG/TROT (TRAB)	-----
EXTENDED TROT	-----
LOPE (GALOPP)	=====
EXTENDED LOPE	=====
BACK UP (RÜCKWÄRTS)	~~~~~
LEAD CHANGE (GALOPPWECHSEL)	=====
TURN (DREHUNG)	⤵
ERSTE	=====
WESTENREITER	=====
UNION	=====
WESTENREITER	=====

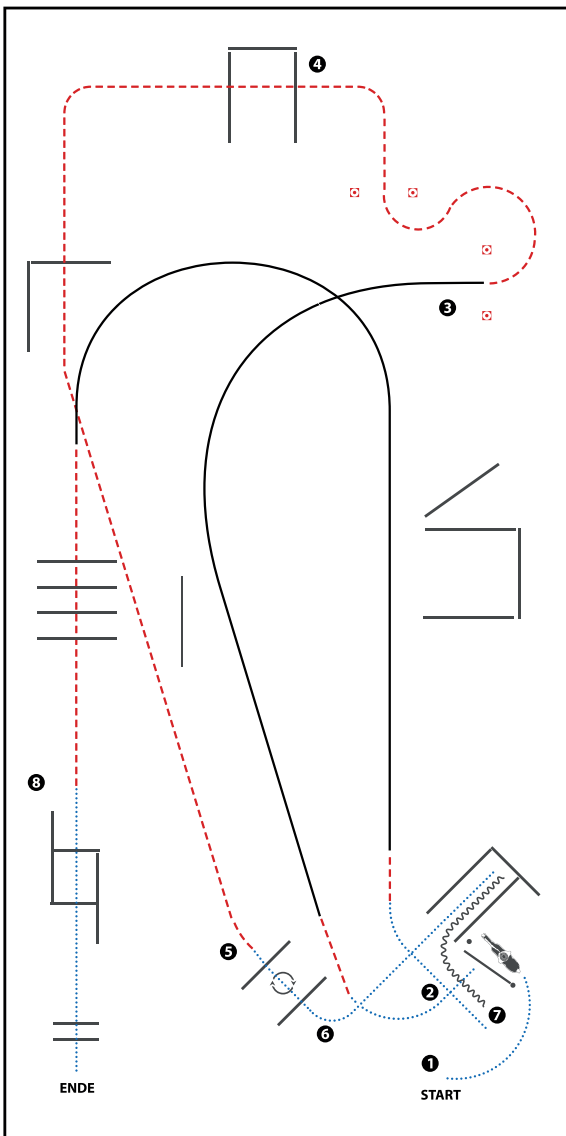

- 1) WALK, GATE, WALK
- 2) JOG, LOPE (RL)
- 3) JOG THRU MARKER
- 4) JOG OVER
- 5) WALK IN BOX, 360° TURN, WALK OUT
- 6) WALK INTO CHUTE, BACK UP
- 7) WALK, JOG, LOPE (LL), JOG OVER
- 8) WALK OVER

WALK (SCHRITT)	
EXTENDED WALK	
JOG/TROT (TRAB)	
EXTENDED TROT	
LOPE (GALOPP)	
EXTENDED LOPE	
BACK UP (RÜCKWÄRTS)	
LEAD CHANGE (GALOPPWECHSEL)	
TURN (DREHUNG)	
ERSTE	
WESTENREITER	
UNION	
WESTENREITER	

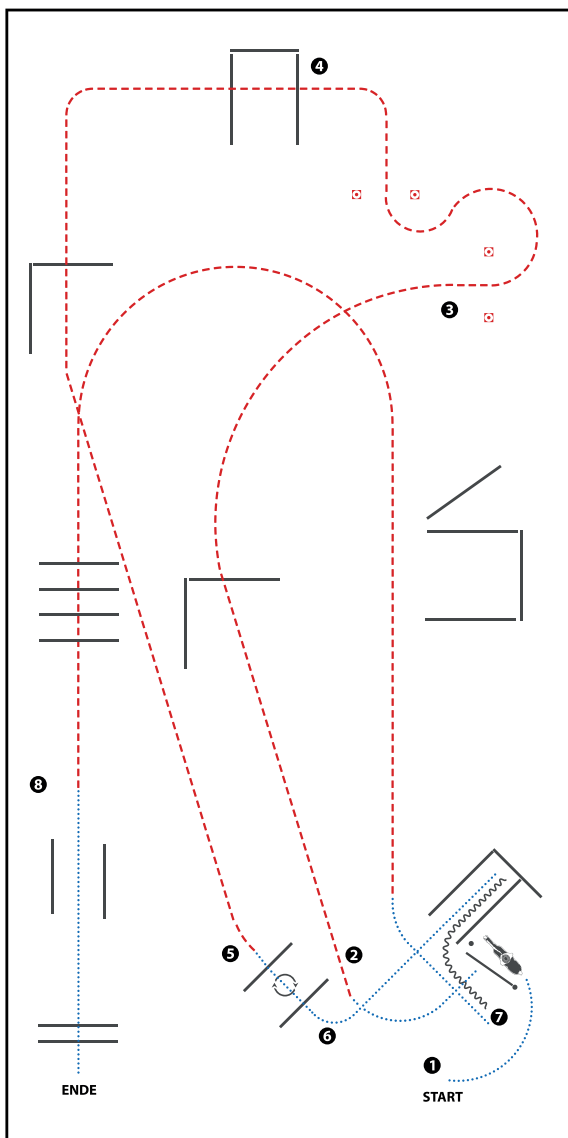

(Tor ist optional)

- 1) WALK, GATE, WALK (Schritt, Tor, schritt)
- 2) JOG OVER (Trabstangen)
- 3) JOG THRU MARKER (Trab durch Marker)
- 4) JOG OVER (Trabstangen)
- 5) WALK IN BOX, 360° TURN RIGHT, WALK OUT
(Im Schritt in die Box, 360° Wendung rechts, im Schritt aus der Box)
- 6) WALK INTO CHUTE, BACK UP
(Im Schritt in die Gasse, Rückwärts)
- 7) WALK, JOG OVER (Schritt, Trabstangen)
- 8) WALK OVER (Schrittstangen)

WALK (SCHRITT)	
EXTENDED WALK	
JOG/TROT (TRAB)	
EXTENDED TROT	
LOPE (GALOPP)	
EXTENDED LOPE	
BACK UP (RÜCKWÄRTS)	
LEAD CHANGE (GALOPPWECHSEL)	
TURN (DREHUNG)	
	ERSTE
	WEITERER
	UNION
	WIEDERHOLER

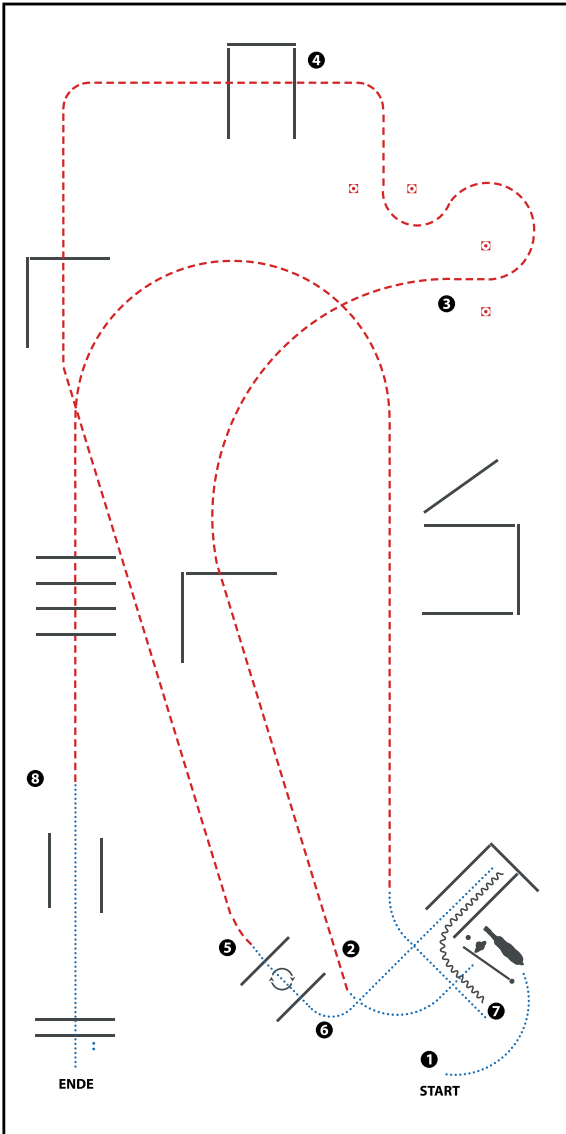

- 1) WALK, GATE, WALK
- 2) JOG OVER
- 3) JOG THRU MARKER
- 4) JOG OVER
- 5) WALK IN BOX, 360° TURN RIGHT, WALK OUT
- 6) WALK INTO CHUTE, BACK UP
- 7) WALK, JOG OVER
- 8) WALK OVER

WALK (SCHRITT)
EXTENDED WALK
JOG/TROT (TRAB)
EXTENDED TROT
LOPE (GALOPP)
EXTENDED LOPE
BACK UP (RÜCKWÄRTS)
LEAD CHANGE (GALOPPWECHSEL)
TURN (DREHUNG)
	ERSTE WESTENREITER UNION WIRTSCHAFTSCHAFTLICHE VERBÄNDER

Trail Set 15

Pattern 1- 9

Arenagröße mind. 25 x 50 m

Für TH-Pattern gelten folgende Abstände und Maße:

WALK / WALK OVER	Abstand 40 - 60 cm • Erhöhung max. 30 cm. Bei Erhöhung sollte der Mindestabstand 55 cm betragen.
JOG / JOG OVER	Abstand 90 - 105 cm • Erhöhung max. 20 cm.
EXTENDED JOG	Abstand 105 - 125 cm.
LOPE / LOPE OVER	Abstand 180 - 210 cm • Erhöhung max. 20 cm.
EXTENDED LOPE	Abstand 210 - 225 cm.
BACK UP	Abstandmind. 100 cm, Erhöhung max. 30 cm.
SIDEPASS	Abstand in einer Gasse mind. 200 cm (ganzes Pferd), mind. 60 cm (1 Beinpaar zwischen zwei Stangen), Erhöhung max. 30 cm.
SERPENTIN WALK	Abstand mind. 200 cm
SERPENTIN JOG	Abstand mind. 250 cm
GATE	Breite mind. 90 cm, Länge 250 cm,
BRIDGE	Breite mind. 150 cm, Länge 250 cm,
BRIDGE WITH RAILING	Breite mind. 150 cm, Länge 250 cm,
BOX	Abstand 180 - 210 cm
JUMP	Erhöhung max. 45 cm

Zwischen den Hindernissen sollte eine:

Trabstrecke von mind. 10,00 m

Galoppstrecke von mind. 20,00 m

Volten sollten für Reiter der LK 5 und 4 nicht weniger als 12,00 m Durchmesser,
für LK 1 bis 3 nicht weniger als 10,00 m betragen

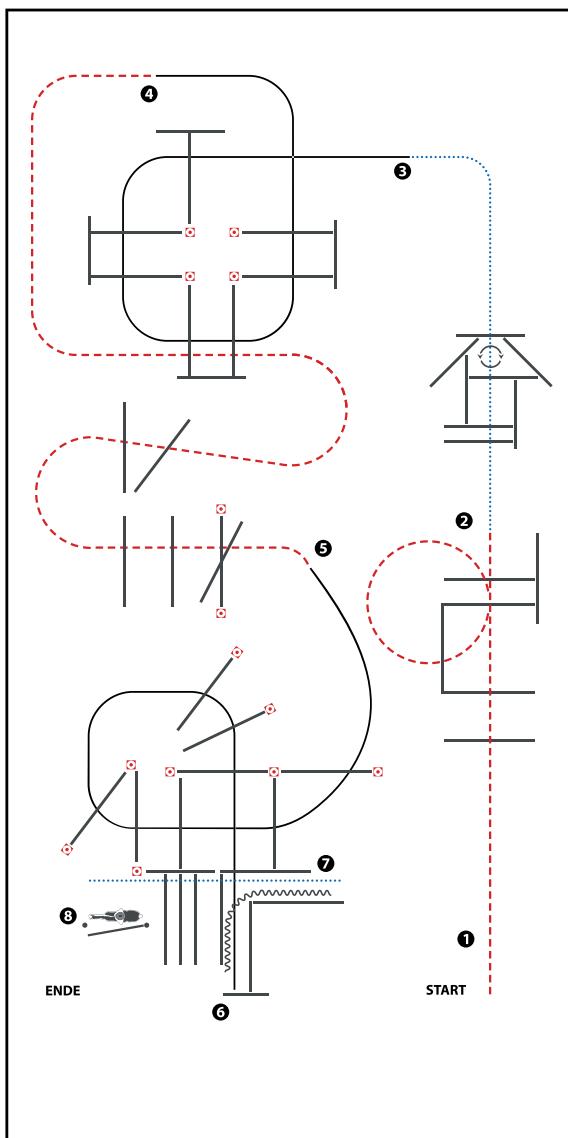

(Erhöhungen optional)

- 1) JOG OVER
- 2) WALK OVER, WALK INTO TRIANGLE, 360° TURN EITHER WAY (LEFT OR RIGHT), WALK OUT
- 3) LOPE OVER (LL)
- 4) JOG OVER
- 5) LOPE OVER (RL), LOPE INTO CHUTE, STOP
- 6) BACK UP
- 7) WALK OVER
- 8) GATE LH

WALK (SCHRITT)	
EXTENDED WALK	
JOG/TROT (TRAB)	
EXTENDED TROT	
LOPE (GALOPP)	
EXTENDED LOPE	
BACK UP (RÜCKWÄRTS)	
LEAD CHANGE (GALOPPWECHSEL)	
TURN (DREHUNG)	
ERSTE	
WESTENREITER	
UNION	
WESTENREITER	

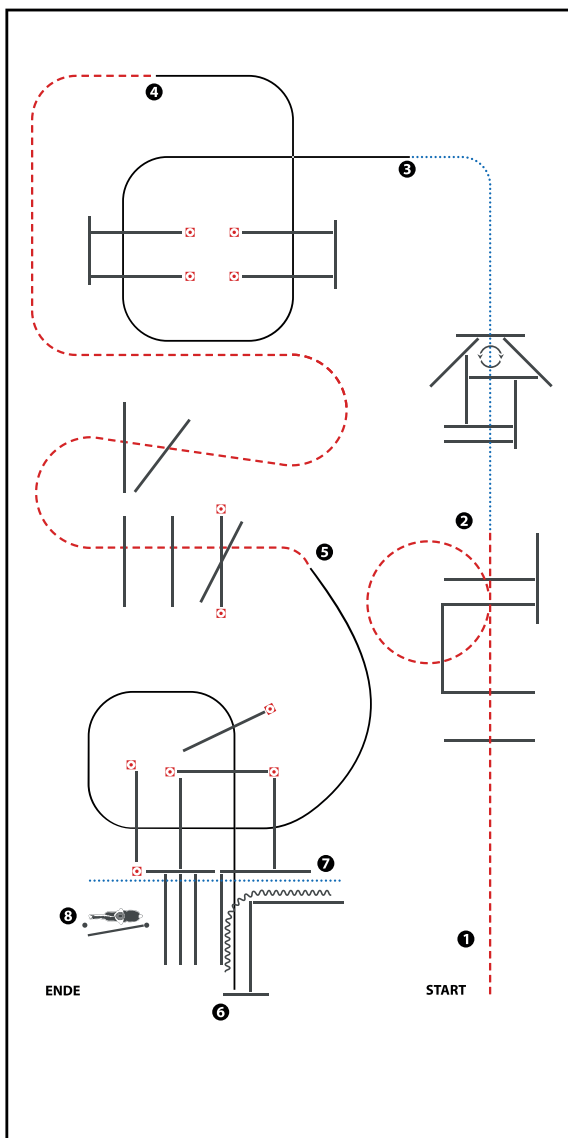

(Erhöhungen optional)

- 1) JOG OVER
- 2) WALK OVER, WALK INTO TRIANGLE, 360° TURN EITHER WAY (LEFT OR RIGHT), WALK OUT
- 3) LOPE OVER (LL)
- 4) JOG OVER
- 5) LOPE OVER (RL), LOPE INTO CHUTE, STOP
- 6) BACK UP
- 7) WALK OVER
- 8) GATE LH

WALK (SCHRITT)
EXTENDED WALK
JOG/TROT (TRAB)	-----
EXTENDED TROT	-----
LOPE (GALOPP)	=====
EXTENDED LOPE	=====
BACK UP (RÜCKWÄRTS)	~~~~~
LEAD CHANGE (GALOPPWECHSEL)	=====
TURN (DREHUNG)	⤵
ERSTE	-----
WESTENREITER	-----
UNION	-----
WESTENREITER	-----

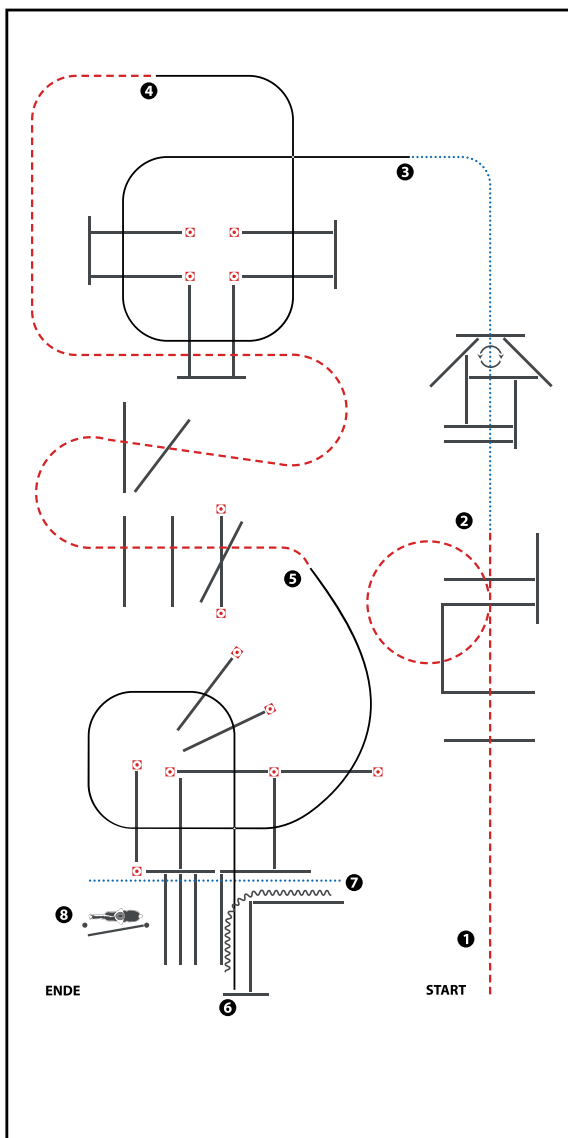

(Erhöhungen optional)

- 1) JOG OVER
- 2) WALK OVER, WALK INTO TRIANGLE, 360° TURN EITHER WAY (LEFT OR RIGHT), WALK OUT
- 3) LOPE OVER (LL)
- 4) JOG OVER
- 5) LOPE OVER (RL), LOPE INTO CHUTE, STOP
- 6) BACK UP
- 7) WALK OVER
- 8) GATE LH

WALK (SCHRITT)	
EXTENDED WALK	
JOG/TROT (TRAB)	
EXTENDED TROT	
LOPE (GALOPP)	
EXTENDED LOPE	
BACK UP (RÜCKWÄRTS)	
LEAD CHANGE (GALOPPWECHSEL)	
TURN (DREHUNG)	
	ERSTE
	WESTENREITER
	UNION
	WELDPFERDEBUND WESTENREITER

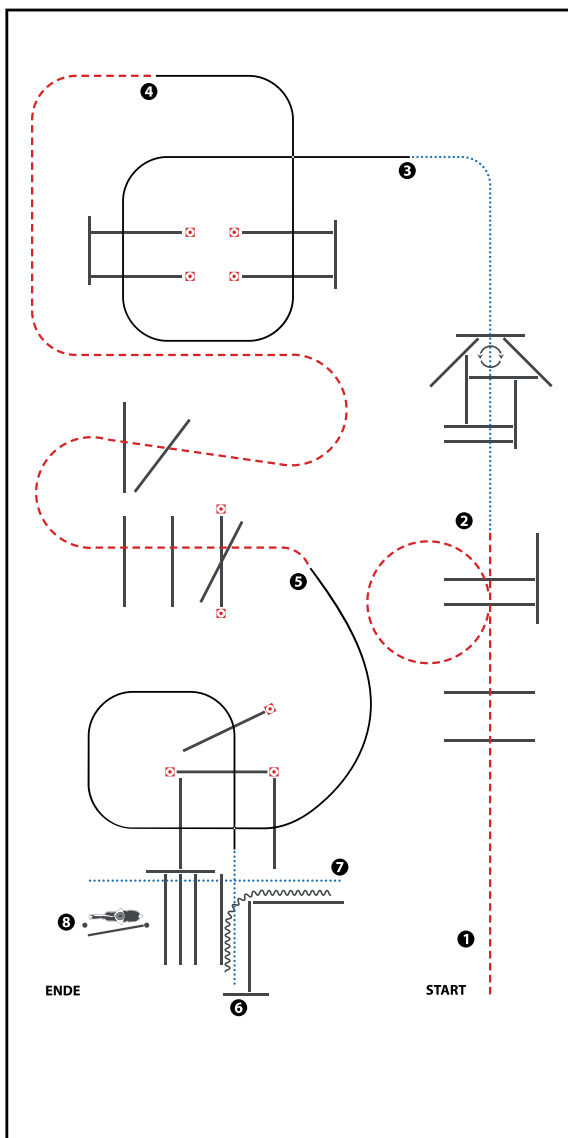

(Erhöhungen optional)

- 1) JOG OVER
- 2) WALK OVER, WALK INTO TRIANGLE,
360° TURN EITHER WAY (LEFT OR RIGHT), WALK OUT
- 3) LOPE OVER (LL)
- 4) JOG OVER
- 5) LOPE OVER (RL), WALK INTO CHUTE, STOP
- 6) BACK UP
- 7) WALK OVER
- 8) GATE LH

WALK (SCHRITT)	
EXTENDED WALK	
JOG/TROT (TRAB)	
EXTENDED TROT	
LOPE (GALOPP)	
EXTENDED LOPE	
BACK UP (RÜCKWÄRTS)	
LEAD CHANGE (GALOPPWECHSEL)	
TURN (DREHUNG)	
ERSTE	
WESTENREITER	
UNION	
WESTENREITER UND WESTENREITER	

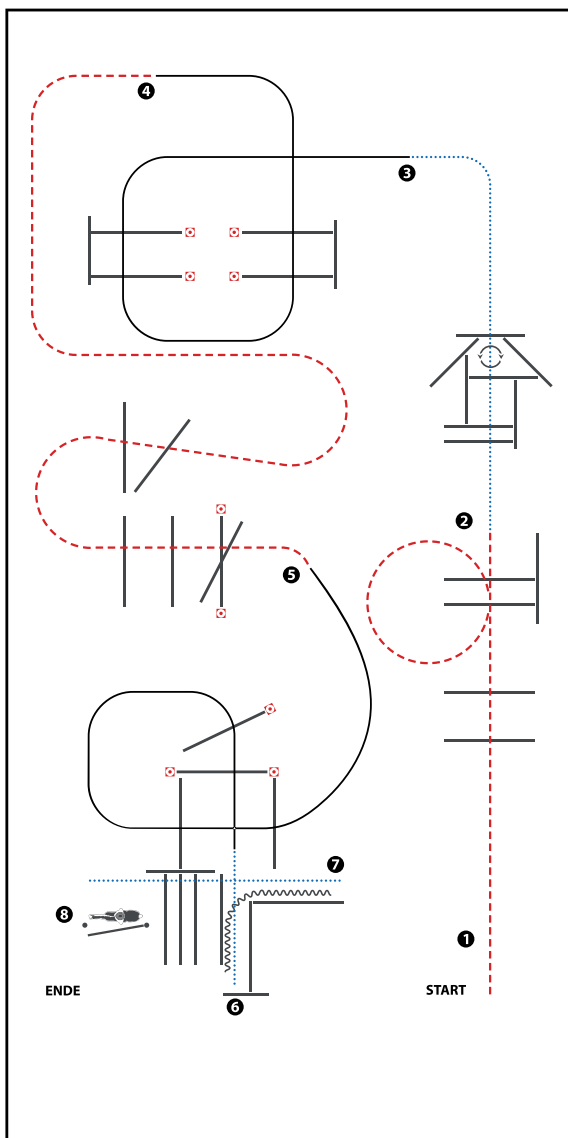

(Erhöhungen optional)

- 1) JOG OVER
- 2) WALK OVER, WALK INTO TRIANGLE,
360° TURN EITHER WAY (LEFT OR RIGHT), WALK OUT
- 3) LOPE OVER (LL)
- 4) JOG OVER
- 5) LOPE OVER (RL), WALK INTO CHUTE, STOP
- 6) BACK UP
- 7) WALK OVER
- 8) GATE LH

WALK (SCHRITT)	
EXTENDED WALK	
JOG/TROT (TRAB)	
EXTENDED TROT	
LOPE (GALOPP)	
EXTENDED LOPE	
BACK UP (RÜCKWÄRTS)	
LEAD CHANGE (GALOPPWECHSEL)	
TURN (DREHUNG)	
	ERSTE
	WEITERER
	UNION
	WIEDERHOLER

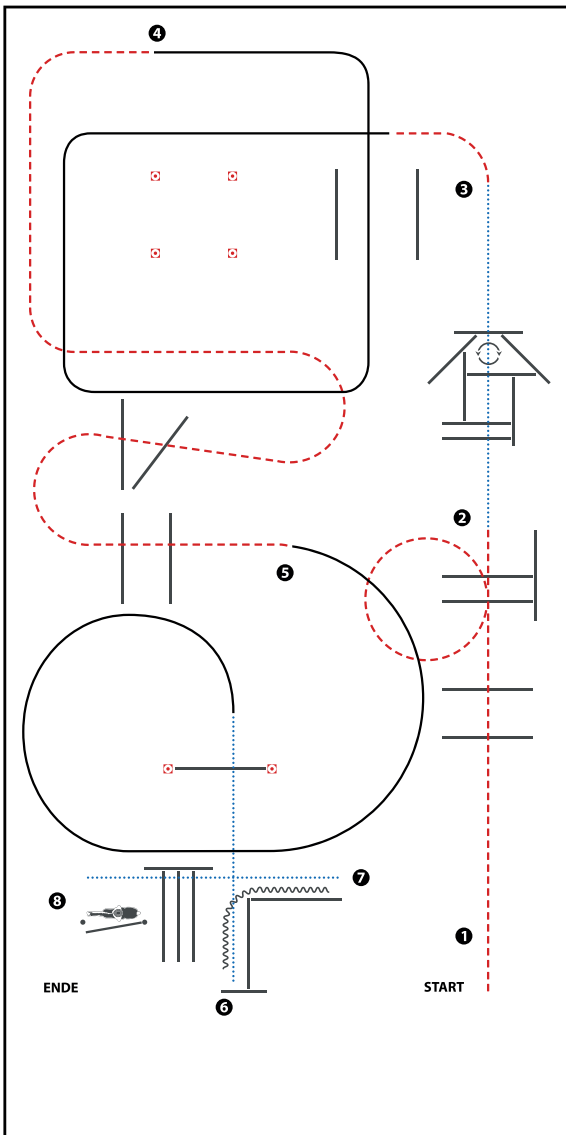

- 1) JOG OVER
- 2) WALK OVER, WALK INTO TRIANGLE,
360° TURN EITHER WAY (LEFT OR RIGHT), WALK OUT
- 3) JOG, LOPE (LL)
- 4) JOG OVER
- 5) LOPE (RL), WALK OVER INTO CHUTE, STOP
- 6) BACK UP
- 7) WALK OVER
- 8) GATE LH

WALK (SCHRITT)	
EXTENDED WALK	
JOG/TROT (TRAB)	
EXTENDED TROT	
LOPE (GALOPP)	
EXTENDED LOPE	
BACK UP (RÜCKWÄRTS)	
LEAD CHANGE (GALOPPWECHSEL)	
TURN (DREHUNG)	
	ERSTE
	WEITERER
	UNION
	WIEDERHOLER

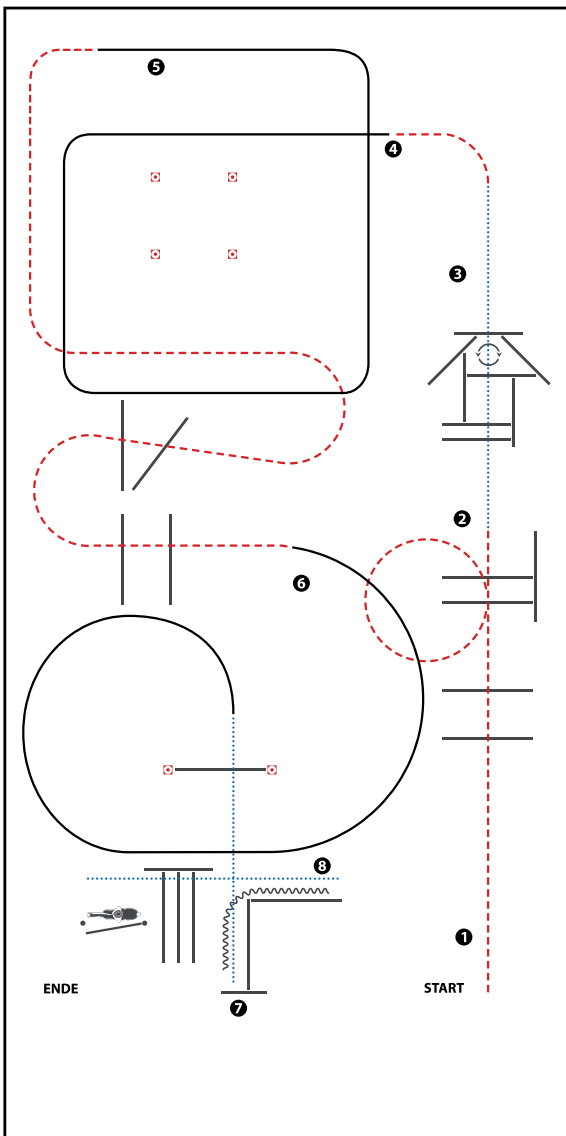

- 1) JOG OVER
- 2) WALK OVER, WALK INTO TRIANGLE,
360° TURN EITHER WAY (LEFT OR RIGHT), WALK OUT
- 3) JOG, LOPE (LL)
- 4) JOG OVER
- 5) LOPE (RL), WALK OVER INTO CHUTE, STOP
- 6) BACK UP
- 7) WALK OVER
- 8) GATE LH

WALK (SCHRITT)	
EXTENDED WALK	
JOE/TROT (TRAB)	
EXTENDED TROT	
LOPE (GALOPP)	
EXTENDED LOPE	
BACK UP (RÜCKWÄRTS)	
LEAD CHANGE (GALOPPWECHSEL)	
TURN (DREHUNG)	
ERSTE	
WESTERWEITER	
UNION	
WIEDERGESCHLOSSEN	

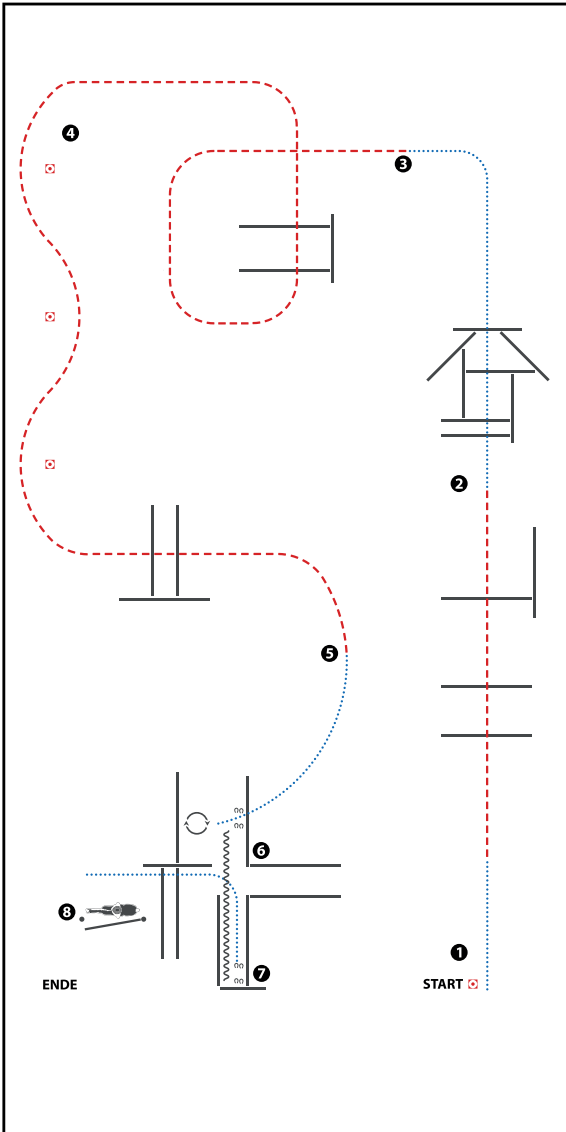

(Tor ist optional)

- 1) WALK, JOG OVER (Schritt, Trabstangen)
- 2) WALK OVER (Schrittstangen)
- 3) JOG OVER (Trabstangen)
- 4) JOG SERPENTINE, JOG OVER (Slalom, Trabstangen)
- 5) WALK INTO BOX, 1 ¼ TURN RIGHT
(Im Schritt in die Box, 1 ¼ Wendung rechts)
- 6) BACK UP (Rückwärts)
- 7) WALK OVER (Schrittstangen)
- 8) GATE LH (Tor linke Hand)

WALK (SCHRITT)
EXTENDED WALK
JOG/TROT (TRAB)
EXTENDED TROT
LOPE (GALOPP)	=====
EXTENDED LOPE	=====
BACK UP (RÜCKWÄRTS)	~~~~~
LEAD CHANGE (GALOPPWECHSEL)	=====
TURN (DREHUNG)	⤵
ERSTE	=====
WESTENREITER	=====
UNION	=====
WELDPFERDEBUND WESTENREITER	=====

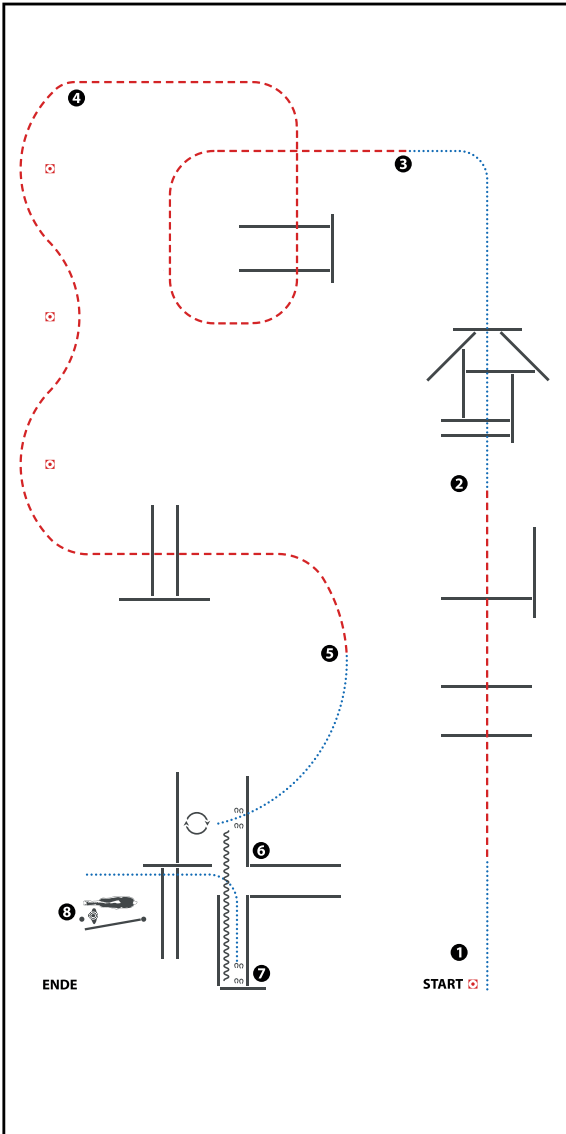

- 1) WALK, JOG OVER
- 2) WALK OVER
- 3) JOG OVER
- 4) JOG SERPENTINE, JOG OVER
- 5) WALK INTO BOX, 1 ¼ TURN RIGHT
- 6) BACK UP
- 7) WALK OVER
- 8) GATE LH

WALK (SCHRITT)
EXTENDED WALK
JOG/TROT (TRAB)
EXTENDED TROT
LOPE (GALOPP)
EXTENDED LOPE
BACK UP (RÜCKWÄRTS)
LEAD CHANGE (GALOPPWECHSEL)
TURN (DREHUNG)
ERSTE
WESTENREITER
UNION
WIRTSCHAFTSUNIVERSITÄT SIEGEN