

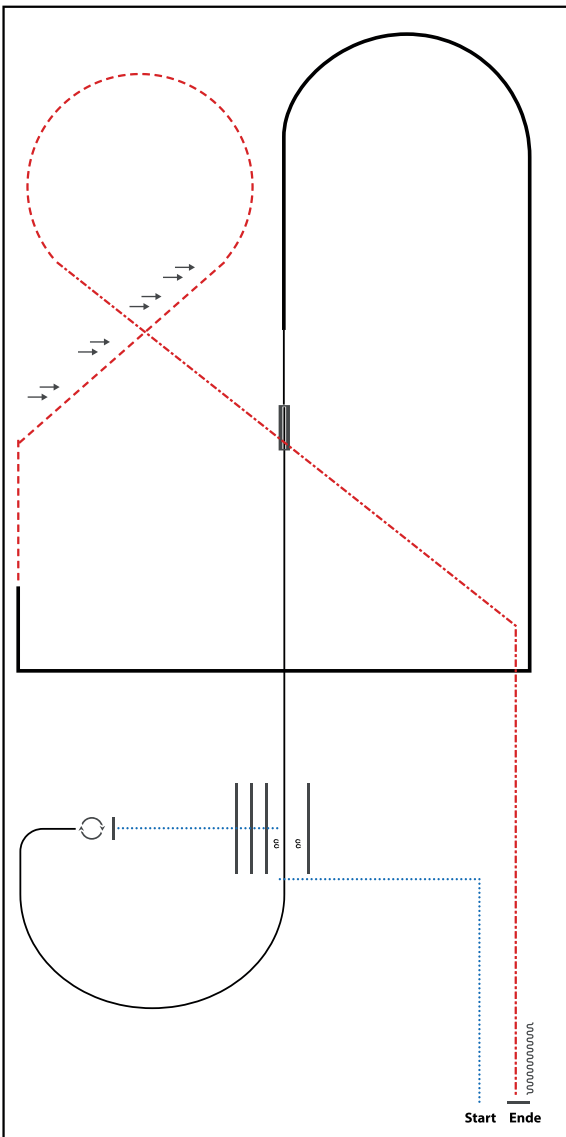



# Ranch Riding Pattern 1 - 39

<b>Inhaltsverzeichnis # 1- 38</b>	<b>Seite 1</b>
# 1 RR Q M sen. LK 1/2	Seite 2
# 2 RR Q M sen. LK 1/2	Seite 3
# 3 RR Q M sen. LK 1/2	Seite 4
# 4 RR Q M sen. LK 1/2	Seite 5
# 5 RR Q M sen. LK 1/2	Seite 6
# 6 RR Q M sen. LK 1/2	Seite 7
# 7 RR Q M sen. LK 1/2	Seite 8
# 8 RR Q M sen. LK 1/2	Seite 9
# 9 RR Q M sen. LK 1/2	Seite 10
#10 RR Q M sen. LK 1/2	Seite 11
#11 RR Q M sen. LK 1/2	Seite 12
#12 RR Q M sen. LK 1/2	Seite 13
#13 RR Q M sen. LK 1/2	Seite 14
#14 RR Q M sen. LK 1/2	Seite 15
#15 RR Q M sen. LK 1/2	Seite 16
#16 RR Q M sen. LK 1/2	Seite 17
#17 RR Q M jun. LK 1/2	Seite 18
#18 RR Q M jun. LK 1/2	Seite 19
#19 RR Q M jun. LK 1/2	Seite 20
#20 RR Q M jun. LK 1/2	Seite 21
#21 RR Q M jun. LK 1/2	Seite 22
#22 RR Q M jun. LK 1/2	Seite 23
#23 RR Q M jun. LK 1/2	Seite 24
#24 RR Q M jun. LK 1/2	Seite 25
#25 RR Q M jun. LK 1/2	Seite 26
#26 RR Q M jun. LK 1/2 und LK 3	Seite 27
#27 RR Q M jun. LK 1/2 und LK 3	Seite 28
#28 RR LK 1-3	Seite 29
#29 RR LK 1-3	Seite 30
#30 RR LK 4/5	Seite 31
#31 RR LK 4/5	Seite 32
#32 RR LK 4/5	Seite 33
#33 RR LK 4/5	Seite 34
#34 RR LK 4/5	Seite 35
#35 RR LK 4/5	Seite 36
#36 RR LK 4/5	Seite 37
#37 RR LK 4/5	Seite 38
#38 RR LK 4/5	Seite 39
#38 RR LK 4/5	Seite 40



- 1) WALK CORNER
- 2) SIDEPASS RIGHT, WALK OVER
- 3) STOP, 360° TURNS (EACH DIRECTION)
- 4) LOPE LL
- 5) CHANGE LEADS (SIMPLE OR FLYING), LOPE RL
- 6) EXTENDED LOPE RL
- 7) EXTENDED LOPE CORNERS
- 8) TROT, TROT TWO TRACK
- 9) TROT
- 10) EXTENDED TROT
- 11) STOP, BACK UP

WALK (SCHRITT)	
EXTENDED WALK	
JOG/TROT (TRAB)	
EXTENDED TROT	
LOPE (GALOPP)	
EXTENDED LOPE	
BACK UP (RÜCKWÄRTS)	
LEAD CHANGE (GALOPPWECHSEL)	
TURN (DREHUNG)	
	ERSTE
	WESTENREITER
	UNION
	PROBENGELEITETES WEITENREITER

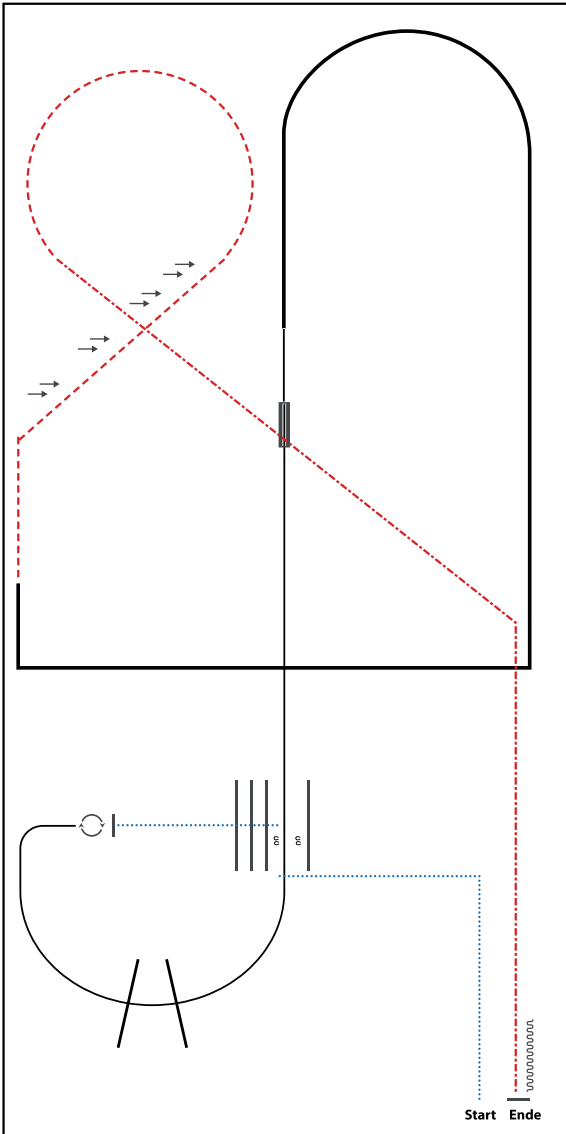

- 1) WALK CORNER
- 2) SIDEPASS RIGHT, WALK OVER
- 3) STOP, 360° TURNS (EACH DIRECTION)
- 4) LOPE LL, LOPE OVER
- 5) CHANGE LEADS (SIMPLE OR FLYING), LOPE RL
- 6) EXTENDED LOPE RL
- 7) EXTENDED LOPE CORNERS
- 8) TROT, TROT TWO TRACK
- 9) TROT
- 10) EXTENDED TROT
- 11) STOP, BACK UP

WALK (SCHRITT)	
EXTENDED WALK	
JOG/TROT (TRAB)	
EXTENDED TROT	
LOPE (GALOPP)	
EXTENDED LOPE	
BACK UP (RÜCKWÄRTS)	
LEAD CHANGE (GALOPPWECHSEL)	
TURN (DREHUNG)	
	ERSTE
	WESTENREITER
	UNION
	PROBENGELEITETES WEITENREITEN

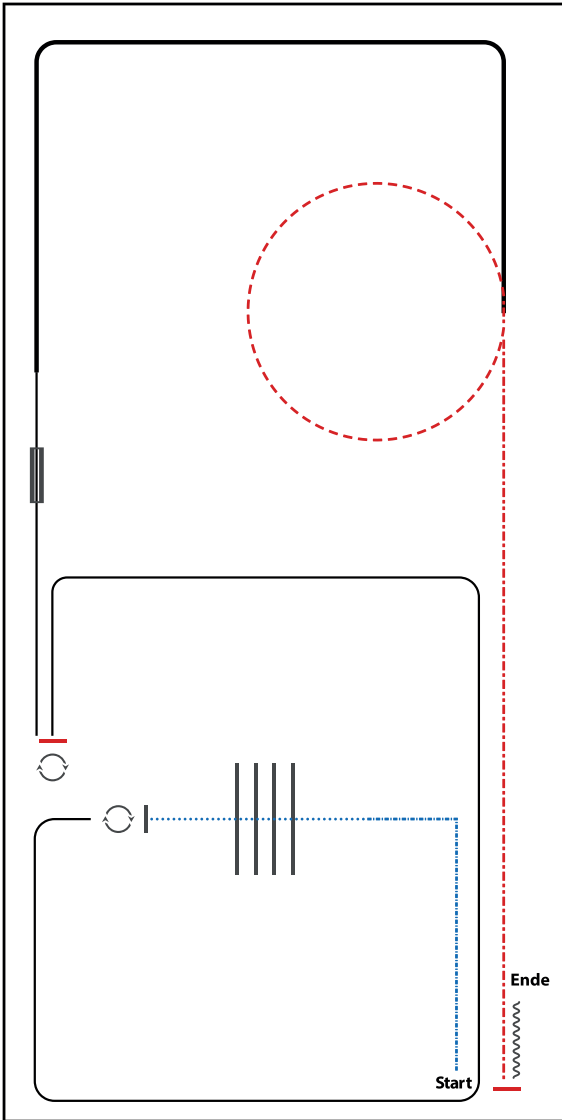

- 1) EXTENDED WALK CORNER
- 2) WALK OVER, WALK
- 3) STOP, 360° TURN LEFT
- 4) LOPE (LL)
- 5) STOP, 180° TURN RIGHT
- 6) LOPE (LL), CHANGE LEADS (SIMPLE OR FLYING)
- 7) LOPE (RL), EXTENDED LOPE (RL)
- 8) TROT, SMALL CIRCLE
- 9) EXTENDED TROT
- 10) STOP, BACK UP

WALK (SCHRITT)	.....
EXTENDED WALK	.....
JOG/TROT (TRAB)	-----
EXTENDED TROT	-----
LOPE (GALOPP)	=====
EXTENDED LOPE	=====
BACK UP (RÜCKWÄRTS)	~~~~~
LEAD CHANGE (GALOPPWECHSEL)	=====
TURN (DREHUNG)	⊙
ERSTE	=====
WESTENREITER	=====
UNION	=====
WESTENREITER	=====





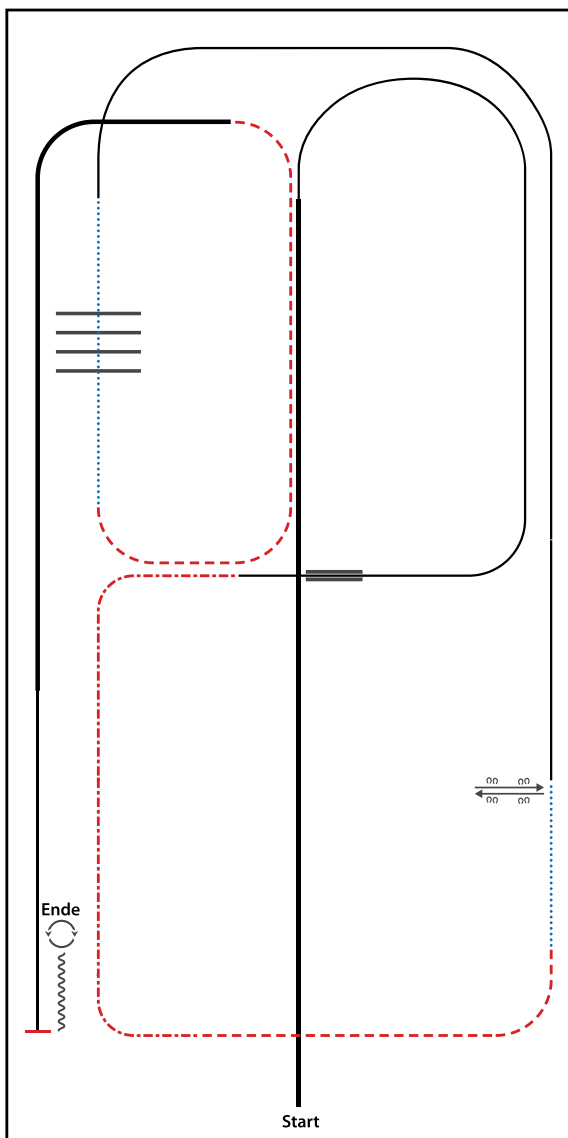

- 1) EXTENDED LOPE (RL)
- 2) LOPE (RL)
- 3) CHANGE LEADS (SIMPLE OR FLYING), LOPE (LL)
- 4) EXTENDED TROT
- 5) TROT
- 6) WALK
- 7) SIDEPASS LEFT, SIDEPASS RIGHT HALF WAY
- 8) LOPE (LL)
- 9) WALK OVER
- 10) TROT
- 11) EXTENDED LOPE (LL), LOPE (LL)
- 12) STOP, BACK UP
- 13) 360° TURNS (EACH DIRECTION)

WALK (SCHRITT)	
EXTENDED WALK	
JOG/TROT (TRAB)	
EXTENDED TROT	
LOPE (GALOPP)	
EXTENDED LOPE	
BACK UP (RÜCKWÄRTS)	
LEAD CHANGE (GALOPPWECHSEL)	
TURN (DREHUNG)	
	ERSTE
	WESTENREITER
	UNION
	WELDMANNREITER



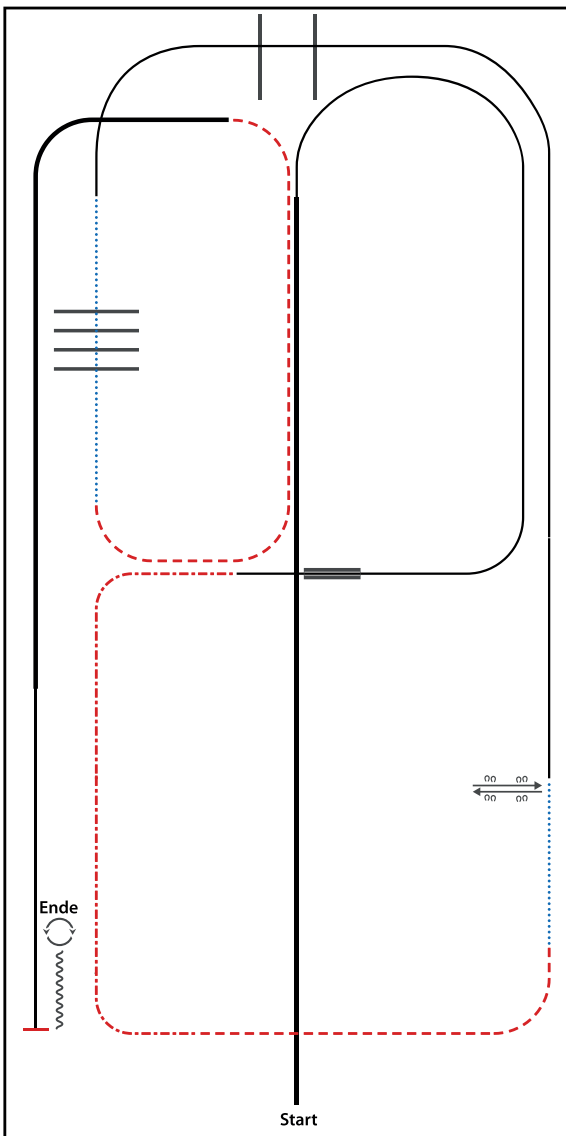

- 1) EXTENDED LOPE (RL)
- 2) LOPE (RL)
- 3) CHANGE LEADS (SIMPLE OR FLYING), LOPE (LL)
- 4) EXTENDED TROT
- 5) TROT
- 6) WALK
- 7) SIDEPASS LEFT, SIDEPASS RIGHT HALF WAY
- 8) LOPE (LL), LOPE OVER
- 9) WALK OVER
- 10) TROT
- 11) EXTENDED LOPE (LL), LOPE (LL)
- 12) STOP, BACK UP
- 13) 360° TURNS (EACH DIRECTION)

WALK (SCHRITT)	
EXTENDED WALK	
JOG/TROT (TRAB)	
EXTENDED TROT	
LOPE (GALOPP)	
EXTENDED LOPE	
BACK UP (RÜCKWÄRTS)	
LEAD CHANGE (GALOPPWECHSEL)	
TURN (DREHUNG)	
	ERSTE
	WESTENREITER
	UNION
	WELDFORPÖRTRÄGGED VESTENREITER

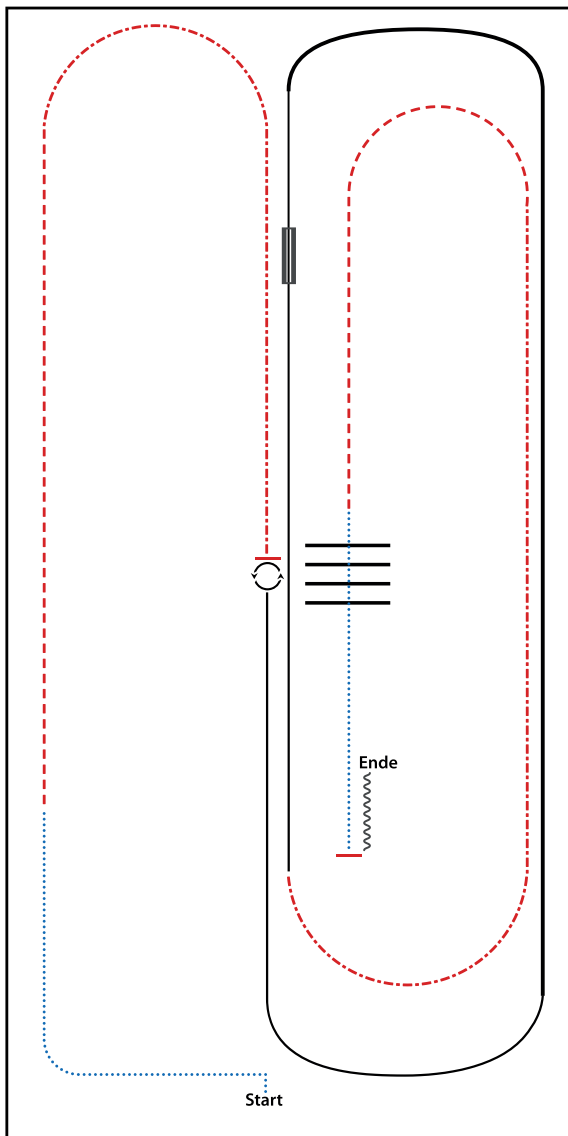

- 1) WALK
- 2) TROT
- 3) EXTENDED TROT
- 4) STOP, 360° TRUNS (EACH DIRECTION)
- 5) LOPE (LL)
- 6) EXTENDED LOPE (LL)
- 7) LOPE (LL), CHANGE LEADS (SIMPLE OR FLYING)
- 8) LOPE (RL)
- 9) EXTENDED TROT
- 10) TROT
- 11) WALK OVER
- 12) STOP, BACK UP

WALK (SCHRITT)	
EXTENDED WALK	
JOG/TROT (TRAB)	
EXTENDED TROT	
LOPE (GALOPP)	
EXTENDED LOPE	
BACK UP (RÜCKWÄRTS)	
LEAD CHANGE (GALOPPWECHSEL)	
TURN (DREHUNG)	
	ERSTE
	WESTENREITER
	UNION
	WELDPFERDEBUND WESTENREITER

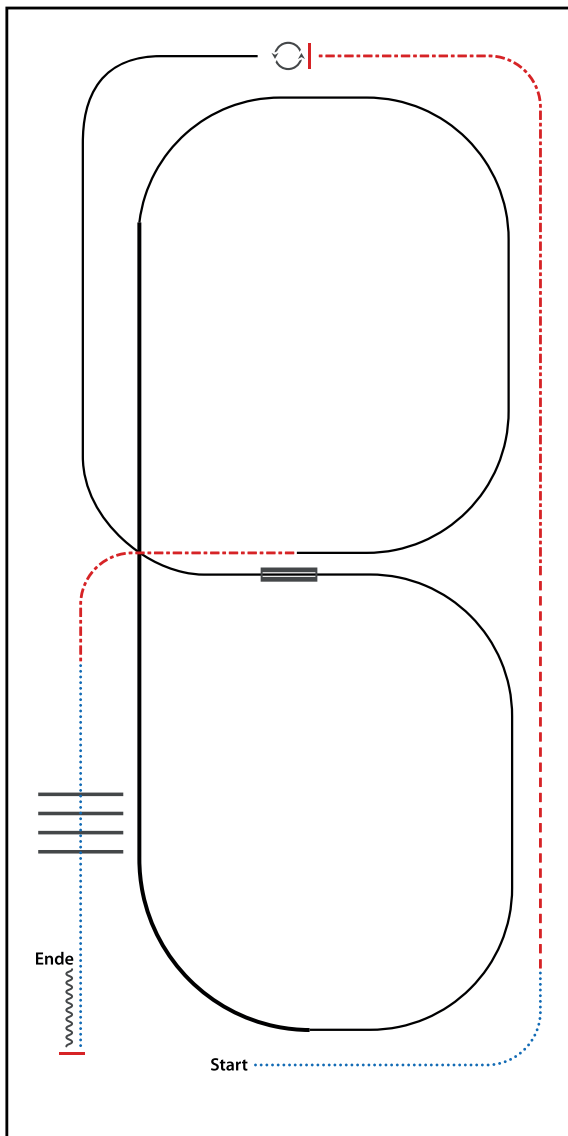

- 1) WALK
- 2) TROT
- 3) EXTENDED TROT, STOP
- 4) 360° TURN LEFT
- 5) LOPE (LL)
- 6) CHANGE LEADS (SIMPLE OR FLYING)
- 7) LOPE (RL)
- 8) EXTENDED LOPE (RL)
- 9) LOPE (RL)
- 10) EXTENDED TROT
- 11) WALK OVER
- 12) STOP, BACK UP

WALK (SCHRITT)	
EXTENDED WALK	
JOG/TROT (TRAB)	
EXTENDED TROT	
LOPE (GALOPP)	
EXTENDED LOPE	
BACK UP (RÜCKWÄRTS)	
LEAD CHANGE (GALOPPWECHSEL)	
TURN (DREHUNG)	
	ERSTE
	WESTENREITER
	UNION
	WESTERUNTERREITER

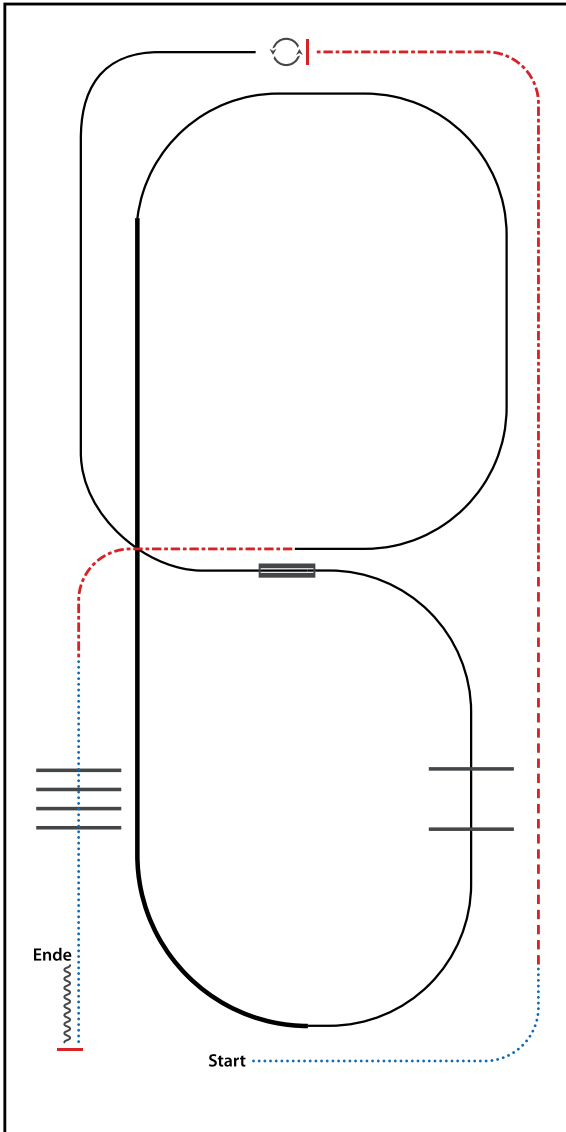

- 1) WALK
- 2) TROT
- 3) EXTENDED TROT, STOP
- 4) 360° TURN LEFT
- 5) LOPE (LL)
- 6) CHANGE LEADS (SIMPLE OR FLYING)
- 7) LOPE (RL), LOPE OVER
- 8) EXTENDED LOPE (RL)
- 9) LOPE (RL)
- 10) EXTENDED TROT
- 11) WALK OVER
- 12) STOP, BACK UP

WALK (SCHRITT)	.....
EXTENDED WALK	-----
JOG/TROT (TRAB)	-----
EXTENDED TROT	-----
LOPE (GALOPP)	-----
EXTENDED LOPE	-----
BACK UP (RÜCKWÄRTS)	~~~~~
LEAD CHANGE (GALOPPWECHSEL)	-----
TURN (DREHUNG)	-----
	
ERSTE	-----
WESTENREITER	-----
UNION	-----
WORLDHORSEPOWER ASSOCIATION	-----

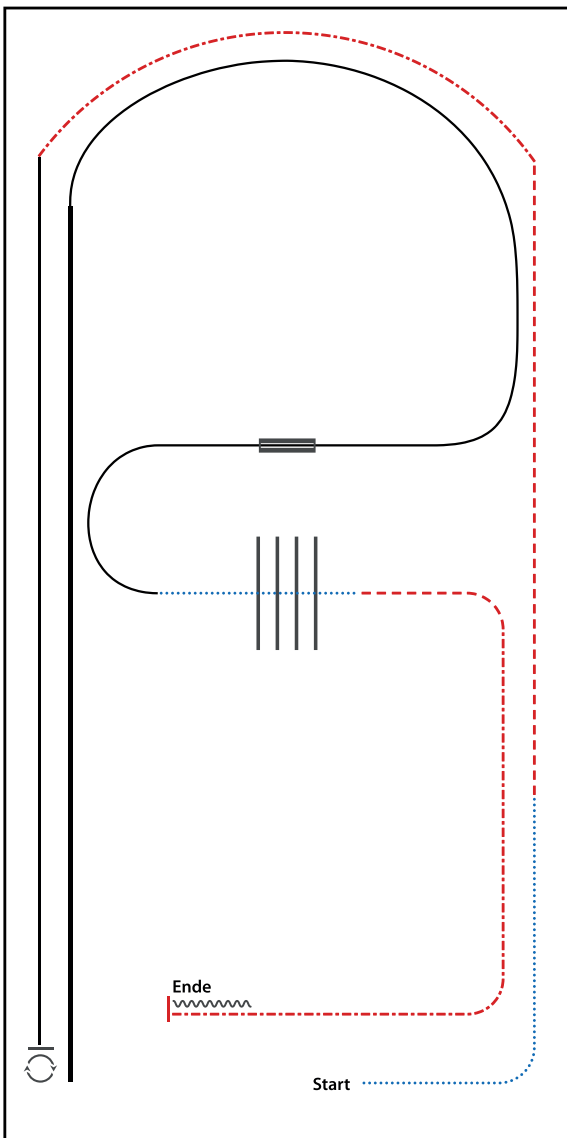

- 1) WALK
- 2) TROT
- 3) EXTENDET TROT
- 4) LOPE (LL)
- 5) STOP, 540° TURN RIGHT
- 6) EXTENDED LOPE (RL)
- 7) LOPE (RL)
- 8) CHANGE LEADS (SIMPLE OR FLYING), LOPE (LL)
- 9) WALK, WALK OVER
- 10) TROT
- 11) EXTENDED TROT
- 12) STOP, BACK UP

WALK (SCHRITT)	
EXTENDED WALK	
JOG/TROT (TRAB)	
EXTENDED TROT	
LOPE (GALOPP)	
EXTENDED LOPE	
BACK UP (RÜCKWÄRTS)	
LEAD CHANGE (GALOPPWECHSEL)	
TURN (DREHUNG)	

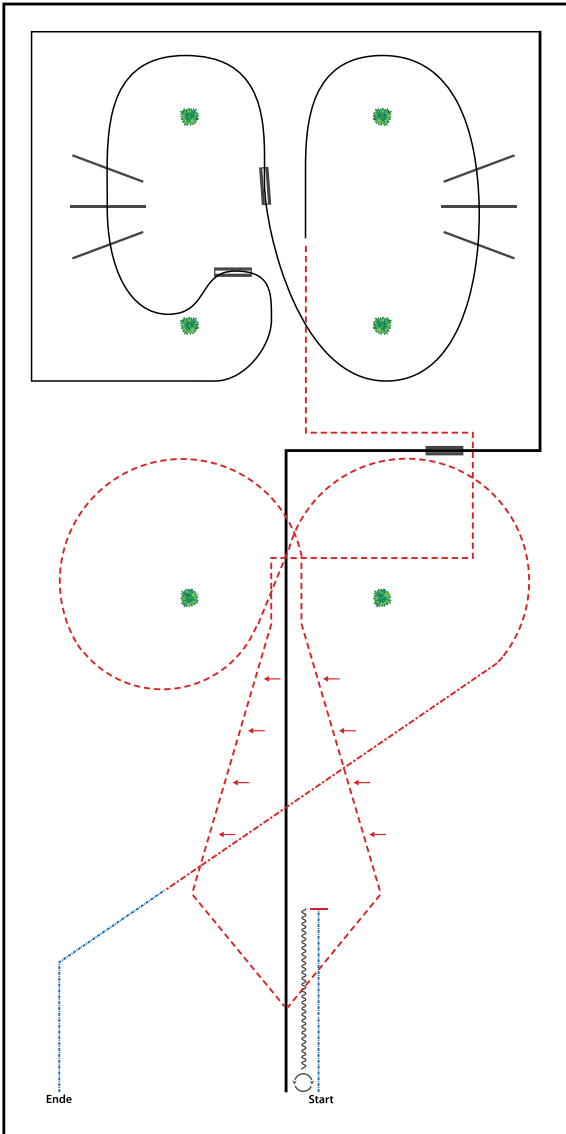

- 1) EXTENDED WALK
- 2) STOP, BACK UP
- 3) TWO TURNS (LEFT OR RIGHT)
- 4) EXTENDED LOPE (RL) CORNER
- 5) CHANGE LEADS
- 6) EXTENDED LOPE (LL) CORNER
- 7) COLLECTED LOPE (LL) CORNERS
- 8) CHANGE LEADS, LOPE OVER (RL)
- 9) CHANGE LEADS, LOPE OVER (LL)
- 10) TROT CORNERS
- 11) TWO TRACK RIGHT, CORNERS, TWO TRACK LEFT
- 12) EXTENDED TROT
- 13) EXTENDED WALK, WALK OUT

WALK (SCHRITT)	
EXTENDED WALK	
JOG/TROT (TRAB)	
EXTENDED TROT	
LOPE (GALOPP)	
EXTENDED LOPE	
BACK UP (RÜCKWÄRTS)	
LEAD CHANGE (GALOPPWECHSEL)	
TURN (DREHUNG)	
	ERSTE
	WESTBREITER
	UNION
	WIRTSCHAFTSUNIVERSITÄT SIEGEN

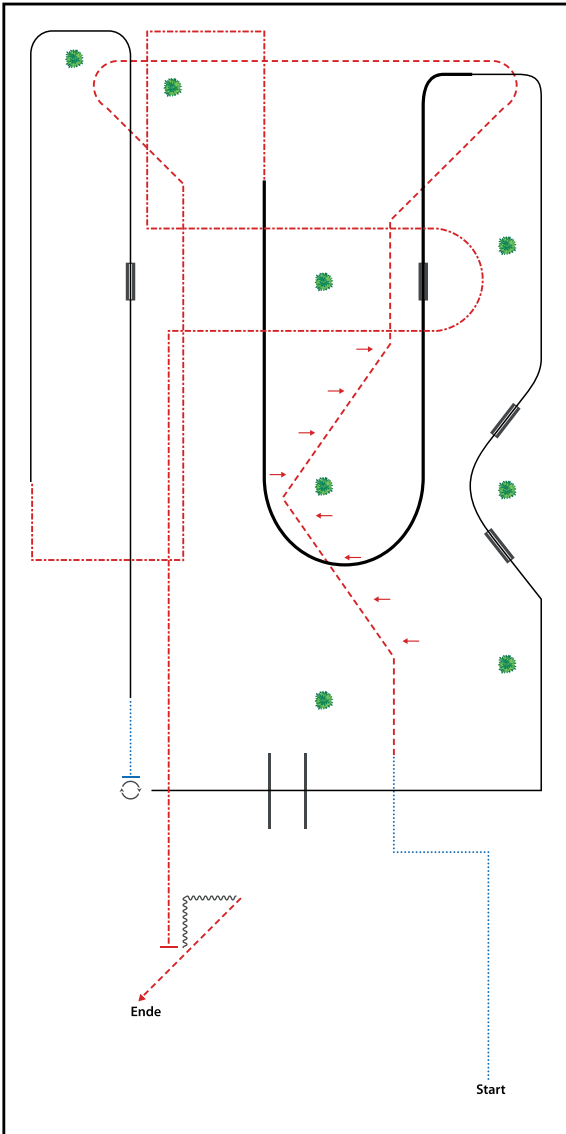

- 1) WALK CORNER
- 2) TROT, TWO TRACK LEFT AND RIGHT
- 3) TROT CORNERS
- 4) EXTENDED TROT CORNER
- 5) LOPE (RL)
- 6) CHANGE LEADS, LOPE (LL)
- 7) WALK, STOP
- 8) 630° TURN RIGHT
- 9) LOPE (LL), LOPE OVER
- 10) LOPE SERPENTINE, TWO LEAD CHANGES
- 11) EXTENDED LOPE (LL)
- 12) CHANGE LEADS, EXTENDED LOPE (RL)
- 13) EXTENDED TROT CORNERS, ARC AND CORNER
- 14) STOP, BACK UP, TROT OUT

WALK (SCHRITT)	
EXTENDED WALK	
JOG/TROT (TRAB)	
EXTENDED TROT	
LOPE (GALOPP)	
EXTENDED LOPE	
BACK UP (RÜCKWÄRTS)	
LEAD CHANGE (GALOPPWECHSEL)	
TURN (DREHUNG)	
ERSTE	
WESTENREITER	
UNION	
WESTENREITER WESTENREITER	

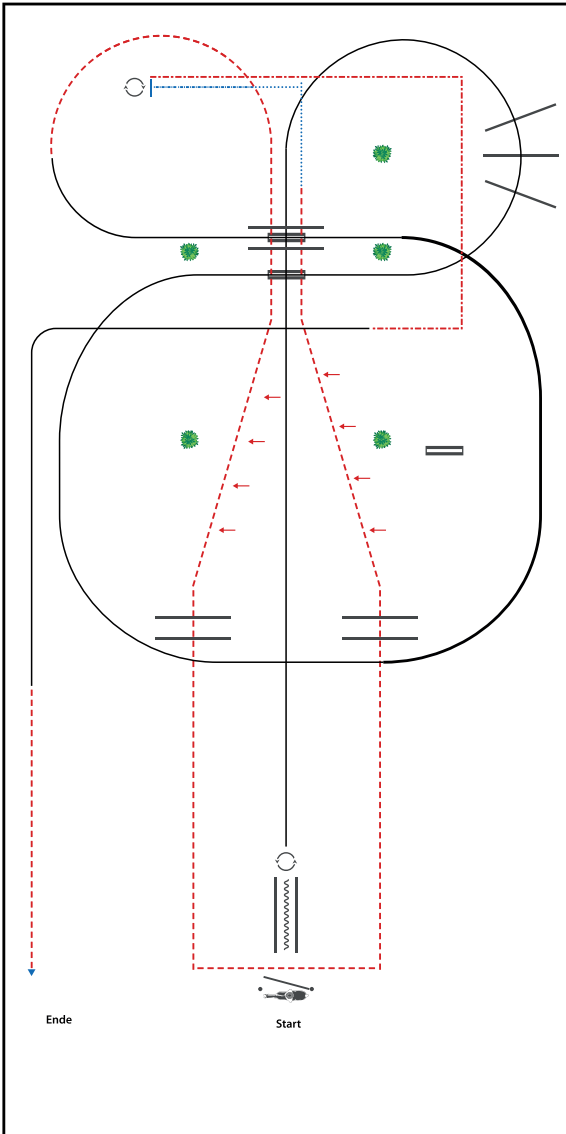

- 1) GATE
- 2) BACK UP
- 3) 540° TURN LEFT
- 4) LOPE (RL), LOPE OVER
- 5) CHANGE LEADS (SIMPLE OR FLYING), LOPE (LL)
- 6) EXTENDED LOPE (LL), COLLECTED LOPE (LL)
- 7) CHANGE LEADS (SIMPLE OR FLYING), LOPE (RL)
- 8) TROT, TROT OVER, TWO TRACK RIGHT AND LEFT
- 9) WALK, EXTENDED WALK
- 10) 540° TURN RIGHT
- 11) EXTENDED TROT CORNERS
- 12) LOPE (LL) CORNER, TROT OUT

WALK (SCHRITT)	.....
EXTENDED WALK	.....
JOG/TROT (TRAB)	.....
EXTENDED TROT	.....
LOPE (GALOPP)	.....
EXTENDED LOPE	.....
BACK UP (RÜCKWÄRTS)	.....
LEAD CHANGE (GALOPPWECHSEL)	.....
TURN (DREHUNG)	.....
ERSTE	.....
WESTENREITER	.....
UNION	.....
WESTENREITER	.....



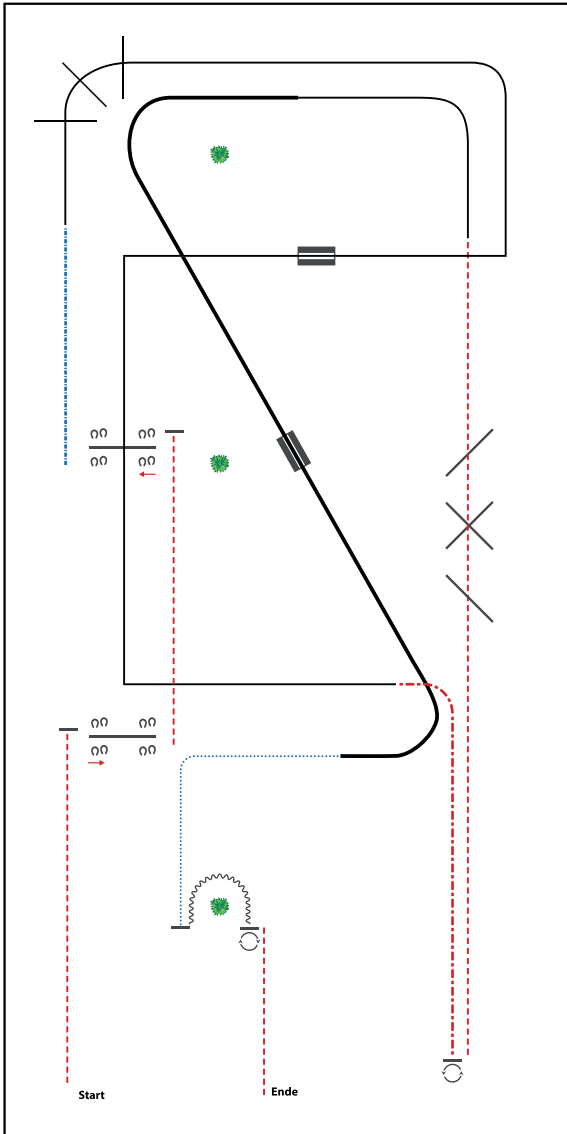

- 1) TROT, STOP, SIDEPASS RIGHT
- 2) TROT, STOP, SIDEPASS LEFT
- 3) EXTENDED WALK
- 4) LOPE (RL), LOPE OVER
- 5) CHANGE LEADS (SIMPLE OR FLYING)
- 6) LOPE CORNERS (LL), LOPE OVER
- 7) EXTENDED TROT, STOP
- 8) 1½ TURN LEFT
- 9) TROT, TROT OVER
- 10) LOPE (LL), EXTENDED LOPE (LL)
- 11) CHANGE LEADS (SIMPLE OR FLYING), EXTENDED LOPE (RL)
- 12) WALK, STOP
- 13) BACK UP
- 14) 1½ TURN RIGHT, TROT OUT

WALK (SCHRITT)	.....
EXTENDED WALK	.....
JOG/TROT (TRAB)	.....
EXTENDED TROT	.....
LOPE (GALOPP)	.....
EXTENDED LOPE	.....
BACK UP (RÜCKWÄRTS)	~~~~~
LEAD CHANGE (GALOPPWECHSEL)	=====
TURN (DREHUNG)	⊙
ERSTE	=====
WESTENREITER	=====
UNION	=====
WESTENREITER	=====

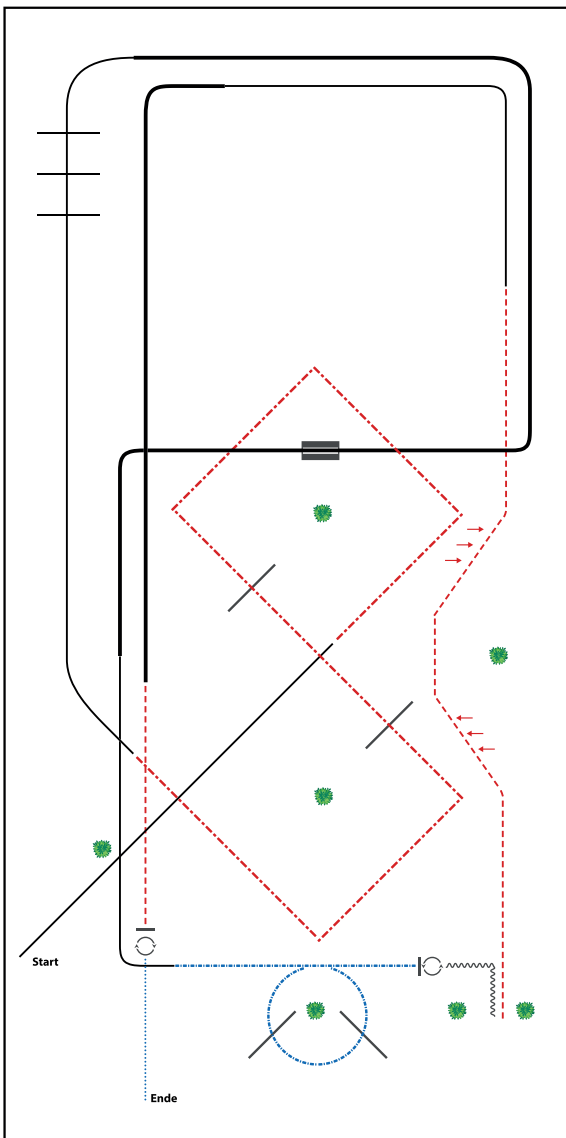

- 1) LOPE (RL OR LL)
- 2) EXTENDED TROT CORNERS, EXTENDED TROT OVER
- 3) LOPE (RL), LOPE OVER
- 4) EXTENDED LOPE (RL)
- 5) CHANGE LEADS (SIMPLE OR FLYING)
- 6) EXTENDED LOPE (LL), LOPE (LL)
- 7) EXTENDED WALK OVER
- 8) STOP, 1½ TURN LEFT
- 9) BACK UP
- 10) TROT, TWO TACK LEFT AND RIGHT
- 11) LOPE (LL), EXTENDED LOPE (LL)
- 12) TROT, STOP
- 13) 2 TURNS RIGHT
- 14) WALK OUT

WALK (SCHRITT)	.....
EXTENDED WALK	.....
JOG/TROT (TRAB)	.....
EXTENDED TROT	.....
LOPE (GALOPP)	.....
EXTENDED LOPE	.....
BACK UP (RÜCKWÄRTS)	.....
LEAD CHANGE (GALOPPWECHSEL)	.....
TURN (DREHUNG)	.....
ERSTE WESTENREITER	.....
UNION	.....
WESTENREITER	.....

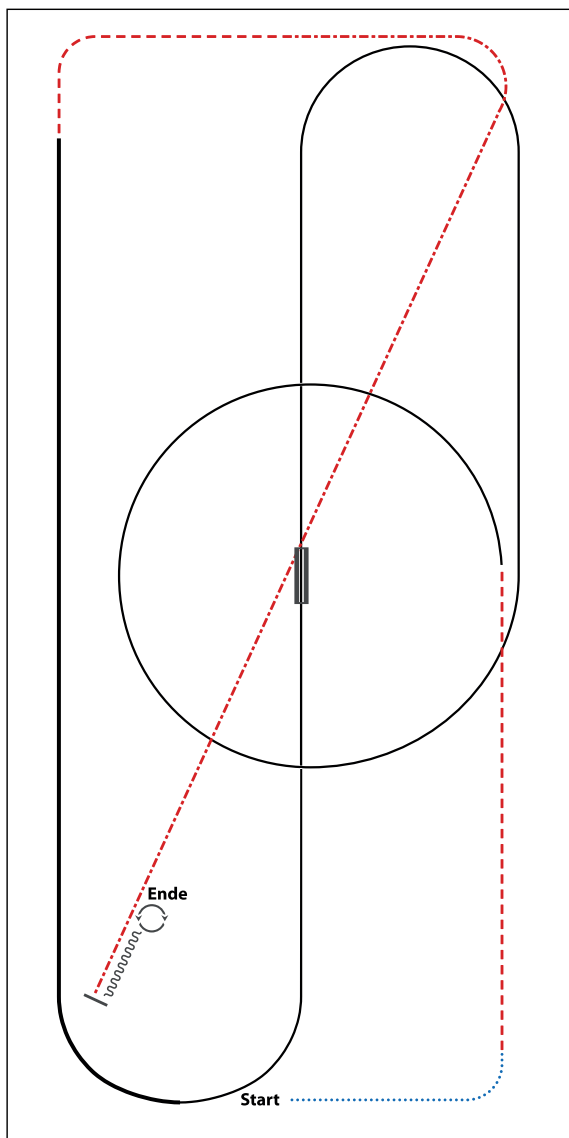

- 1) WALK
- 2) TROT
- 3) LOPE (LL) CIRCLE
- 4) CHANGE LEADS (SIMPLE OR FLYING)
- 5) LOPE (RL)
- 6) EXTENDED LOPE (RL)
- 7) TROT
- 8) EXTENDED TROT
- 9) STOP, BACK UP
- 10) 360° TURNS (EACH DIRECTION)

WALK (SCHRITT)	
EXTENDED WALK	
JOG/TROT (TRAB)	
EXTENDED TROT	
LOPE (GALOPP)	
EXTENDED LOPE	
BACK UP (RÜCKWÄRTS)	
LEAD CHANGE (GALOPPWECHSEL)	
TURN (DREHUNG)	
	ERSTE
	WESTENREITER
	UNION
	WIRTSCHAFTSREITER

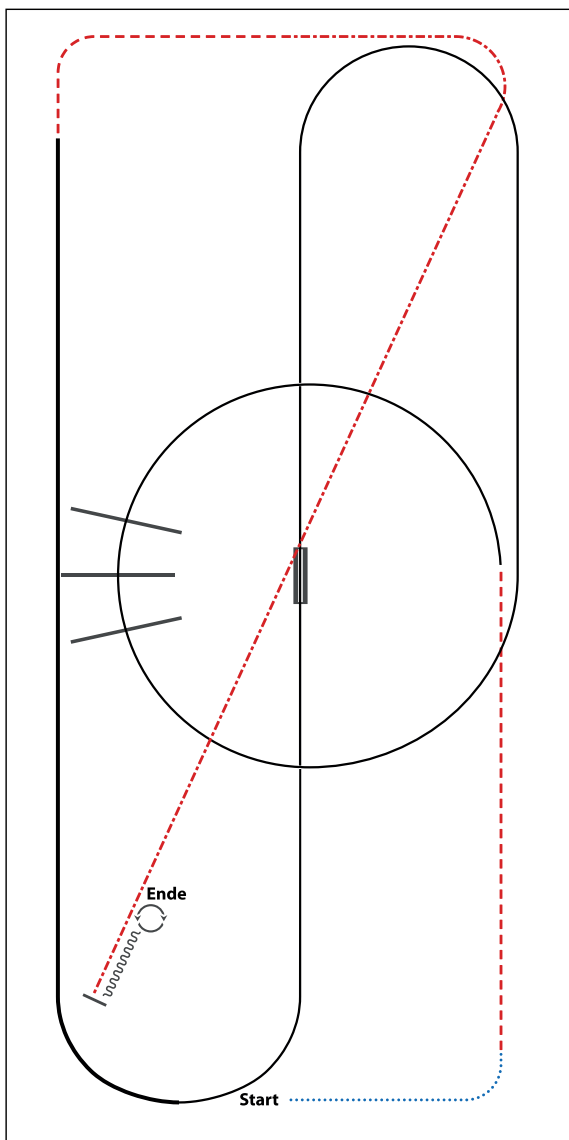

- 1) WALK
- 2) TROT
- 3) LOPE (LL) CIRCLE, LOPE OVER
- 4) CHANGE LEADS (SIMPLE OR FLYING)
- 5) LOPE (RL)
- 6) EXTENDED LOPE (RL)
- 7) TROT
- 8) EXTENDED TROT
- 9) STOP, BACK UP
- 10) 360° TURNS (EACH DIRECTION)

WALK (SCHRITT)	
EXTENDED WALK	
JOG/TROT (TRAB)	
EXTENDED TROT	
LOPE (GALOPP)	
EXTENDED LOPE	
BACK UP (RÜCKWÄRTS)	
LEAD CHANGE (GALOPPWECHSEL)	
TURN (DREHUNG)	
	ERSTE
	WESTENREITER
	UNION
	WIRTSCHAFTSUNIVERSITÄT SIEGEN

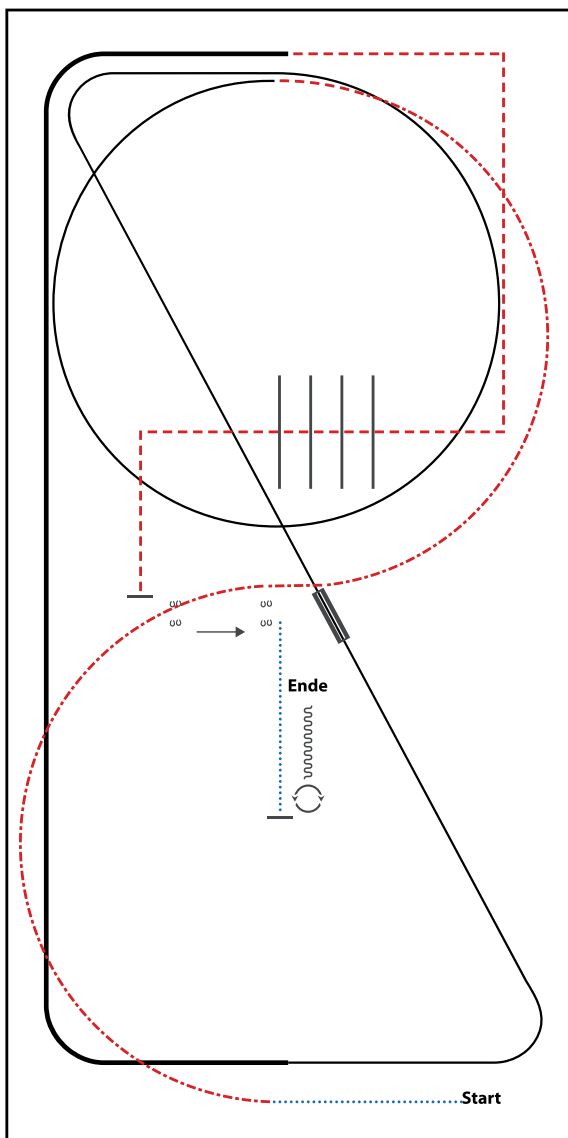

- 1) WALK
- 2) EXTENDED TROT, TROT
- 3) LOPE (LL) CIRCLE, LOPE (LL)
- 4) CHANGE LEADS (SIMPLE OR FLYING)
- 5) LOPE (RL)
- 6) EXTENDED LOPE (RL)
- 7) TROT CORNERS
- 8) TROT OVER, TROT
- 9) STOP, SIDEPASS LEFT
- 10) WALK, STOP
- 11) 360° TURN (LEFT OR RIGHT), BACK UP

WALK (SCHRITT)	.....
EXTENDED WALK	.....
JOG/TROT (TRAB)	.....
EXTENDED TROT	.....
LOPE (GALOPP)	.....
EXTENDED LOPE	.....
BACK UP (RÜCKWÄRTS)	.....
LEAD CHANGE (GALOPPWECHSEL)	.....
TURN (DREHUNG)	.....
ERSTE	.....
WESTENREITER	.....
UNION	.....
WESTENREITER	.....

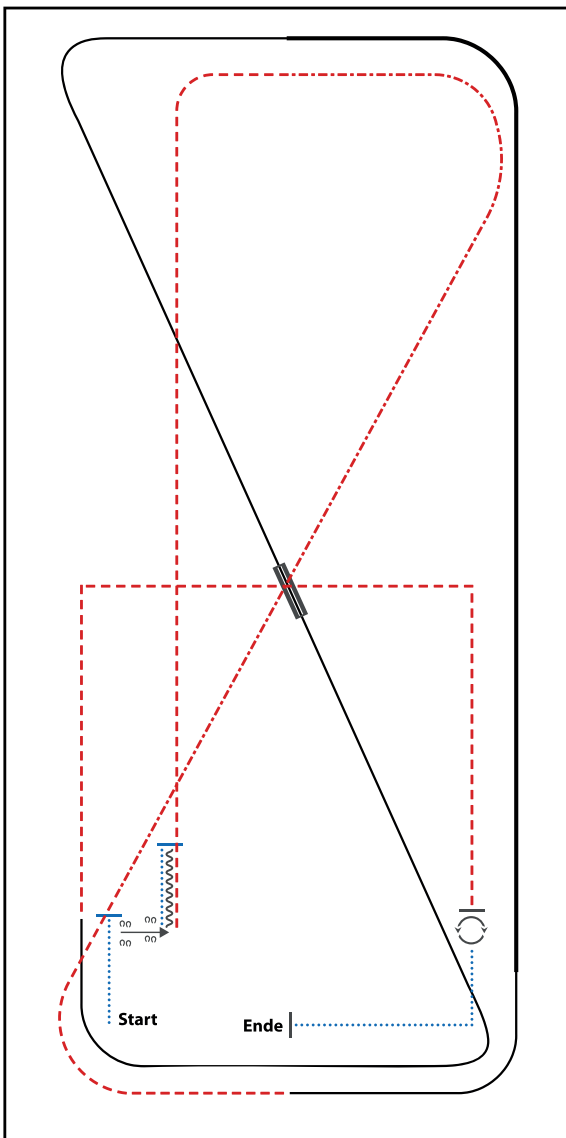

- 1) WALK, STOP
- 2) SIDEPASS RIGHT
- 3) WALK, STOP, BACK UP
- 4) TROT
- 5) EXTENDED TROT, TROT
- 6) LOPE (LL)
- 7) EXTENDED LOPE (LL), LOPE (LL)
- 8) CHANGE LEADS (SIMPLE OR FLYING)
- 9) LOPE (RL)
- 10) TROT CORNERS
- 11) STOP, 360° TURN (LEFT OR RIGHT)
- 12) WALK, STOP

WALK (SCHRITT)	
EXTENDED WALK	
JOG/TROT (TRAB)	
EXTENDED TROT	
LOPE (GALOPP)	
EXTENDED LOPE	
BACK UP (RÜCKWÄRTS)	
LEAD CHANGE (GALOPPWECHSEL)	
TURN (DREHUNG)	
	ERSTE
	WESTENREITER
	UNION
	WELDPFERDEBUND WESTERWALD

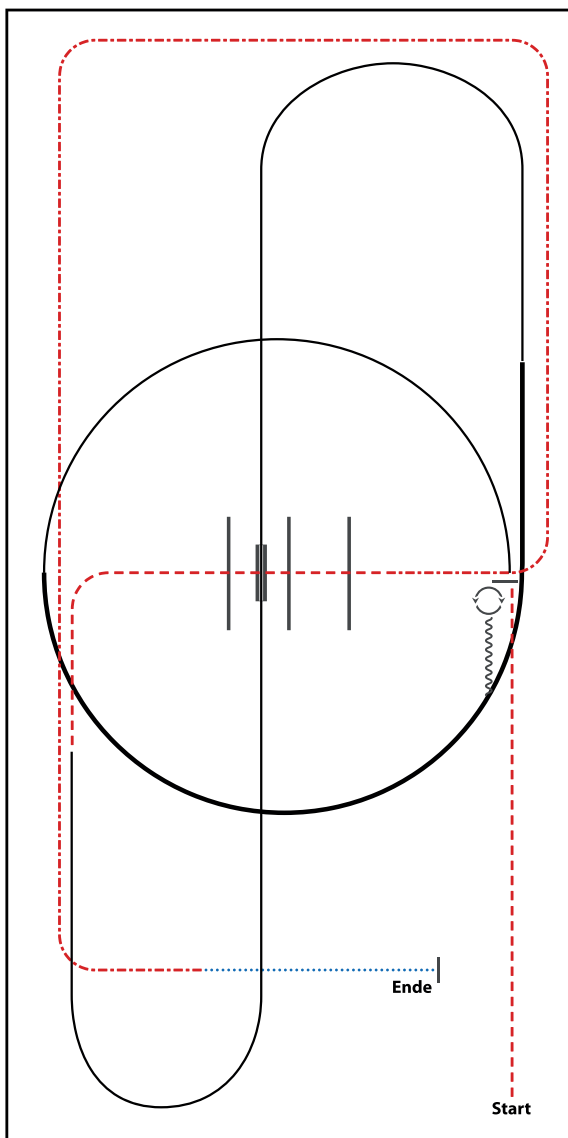

- 1) TROT
- 2) STOP, 180° TURNS EACH DIRECTION
- 3) BACK UP
- 4) LOPE (LL)
- 5) EXTENDED LOPE (LL), LOPE (LL)
- 6) CHANGE LEADS (SIMPLE OR FLYING)
- 7) LOPE (RL)
- 8) TROT, TROT OVER
- 9) EXTENDED TROT
- 10) WALK, STOP

WALK (SCHRITT)	
EXTENDED WALK	
JOG/TROT (TRAB)	
EXTENDED TROT	
LOPE (GALOPP)	
EXTENDED LOPE	
BACK UP (RÜCKWÄRTS)	
LEAD CHANGE (GALOPPWECHSEL)	
TURN (DREHUNG)	
	ERSTE
	WESTENREITER
	UNION
	WELDFÖRDERNDE VEREINIGUNG

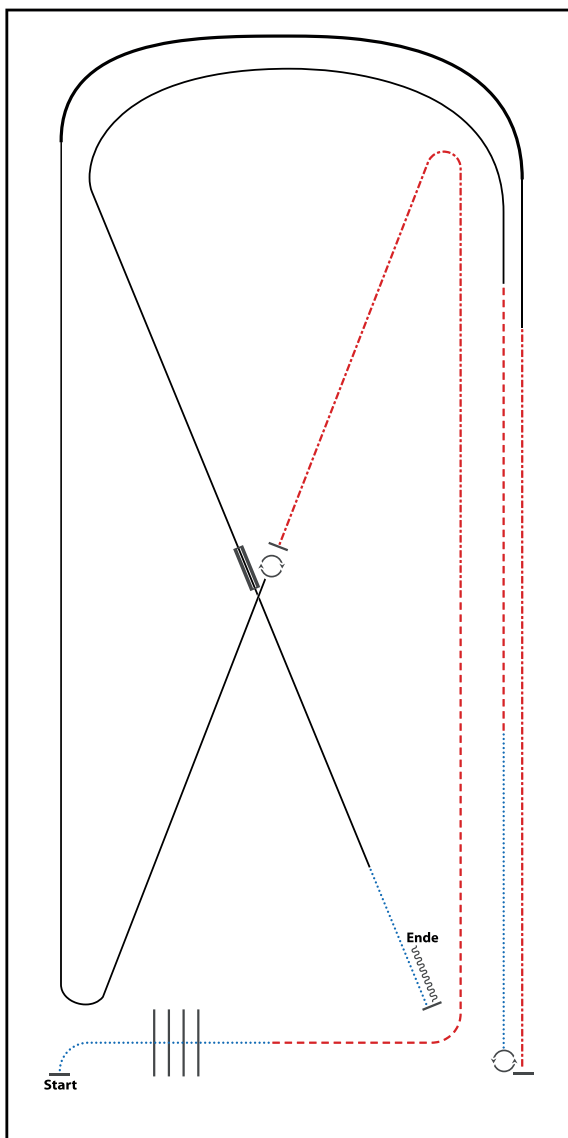

- 1) WALK OVER
- 2) TROT
- 3) EXTENDED TROT
- 4) STOP, 360° TURN RIGHT
- 5) LOPE (RL)
- 6) EXTENDED LOPE (RL), LOPE (RL)
- 7) EXTENDED TROT
- 8) STOP, 540° TURN LEFT
- 9) WALK
- 10) TROT
- 11) LOPE (LL)
- 12) CHANGE LEADS (SIMPLE OR FLYING), LOPE (RL)
- 13) WALK, STOP, BACK UP

WALK (SCHRITT)	.....
EXTENDED WALK	-----
JOG/TROT (TRAB)	-----
EXTENDED TROT	-----
LOPE (GALOPP)	-----
EXTENDED LOPE	-----
BACK UP (RÜCKWÄRTS)	~~~~~
LEAD CHANGE (GALOPPWECHSEL)	=====
TURN (DREHUNG)	⊙
ERSTE	=====
WESTENREITER	-----
UNION	-----
WESTENREITER WESTENREITER	-----



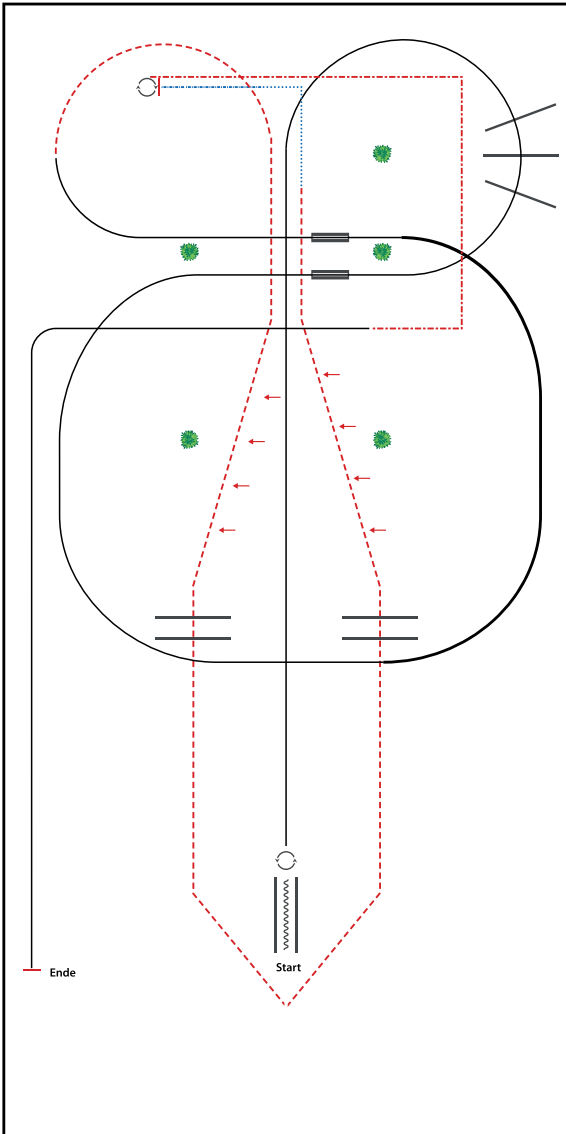

- 1) BACK UP
- 2) 45° TURN (LEFT OR RIGHT)
- 3) LOPE (RL), LOPE OVER
- 4) CHANGE LEADS, LOPE (LL)
- 5) EXTENDED LOPE (LL), COLLECTED LOPE (LL)
- 6) CHANGE LEADS, LOPE (RL)
- 7) TROT, TWO TRACK RIGHT, TROT OVER, CORNERS, TROT OVER, TWO TRACK LEFT
- 8) WALK, EXTENDED WALK
- 9) 45° TURN (LEFT OR RIGHT)
- 10) EXTENDED TROT CORNERS
- 11) LOPE (LL) CORNER, STOP

WALK (SCHRITT)	.....
EXTENDED WALK	.....
JOG/TROT (TRAB)	-----
EXTENDED TROT	-----
LOPE (GALOPP)	=====
EXTENDED LOPE	=====
BACK UP (RÜCKWÄRTS)	~~~~~
LEAD CHANGE (GALOPPWECHSEL)	=====
TURN (DREHUNG)	⤵
	ERSTE WESTENREITER UNION WIRTSCHAFTSCHAFTSCHAFT



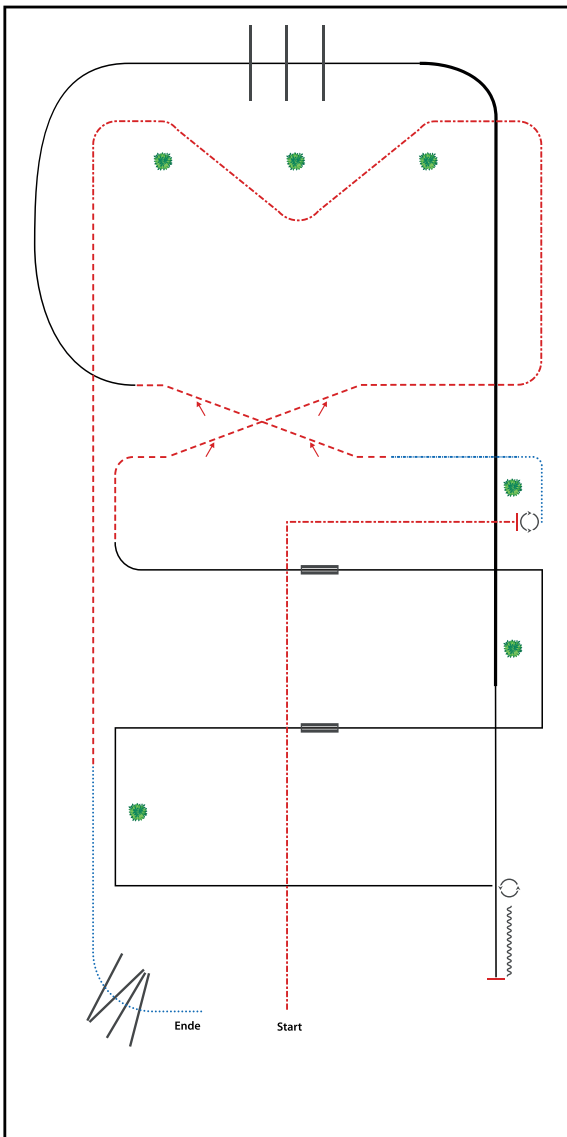

- 1) EXTENDED TROT CORNER
- 2) STOP, 2¼ TURN LEFT
- 3) WALK, EXTENDED WALK
- 4) TROT, TWO TRACK RIGHT
- 5) LOPE (RL), LOPE OVER
- 6) EXTENDED LOPE (RL), COLLECTED LOPE (RL)
- 7) STOP, BACK UP
- 8) 2¼ TURN RIGHT
- 9) LOPE (RL) CORNERS
- 10) CHANGE LEADS, LOPE (LL) CORNERS
- 11) CHANGE LEADS, LOPE (RL)
- 12) TROT, TWO TRACK LEFT
- 13) EXTENDED TROT, TROT
- 14) WALK, WALK OVER, WALK OUT

WALK (SCHRITT)	.....
EXTENDED WALK	.....
JOG/TROT (TRAB)	.....
EXTENDED TROT	.....
LOPE (GALOPP)	.....
EXTENDED LOPE	.....
BACK UP (RÜCKWÄRTS)	~~~~~
LEAD CHANGE (GALOPPWECHSEL)	=====
TURN (DREHUNG)	⤵
ERSTE	=====
WESTENREITER	=====
UNION	=====
WESTENREITER WESTENREITER	=====

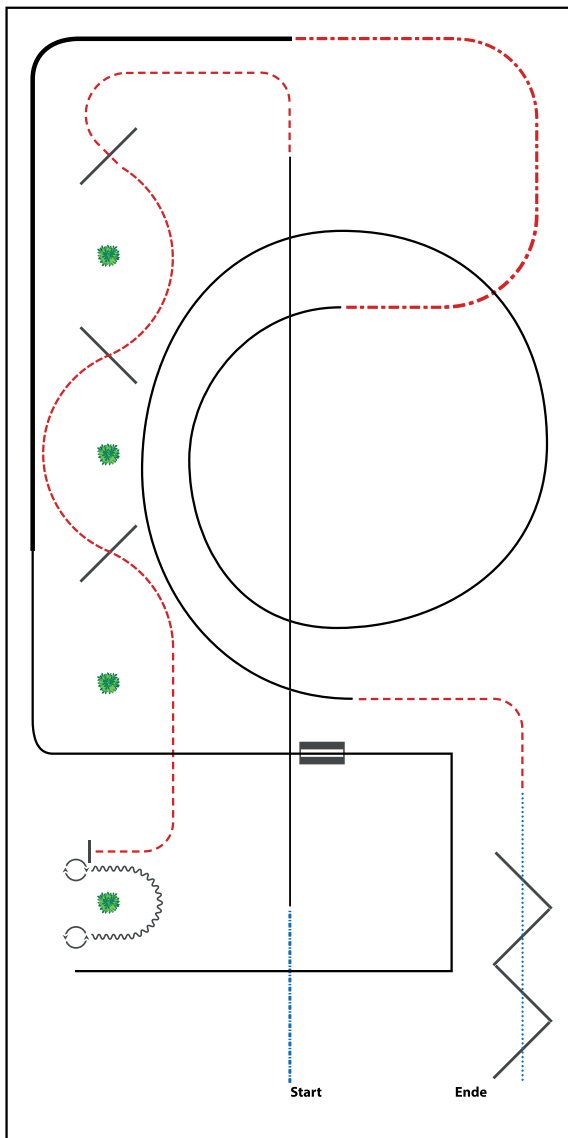

- 1) EXTENDED WALK
- 2) LOPE (RL OR LL)
- 3) TROT, TROT OVER
- 4) STOP, 360° TURN RIGHT
- 5) BACK UP
- 6) 360° TURN LEFT
- 7) LOPE CORNERS (LL)
- 8) CHANGE LEADS, LOPE (RL)
- 9) EXTENDED LOPE (RL)
- 10) EXTENDED TROT
- 11) LOPE (LL)
- 12) TROT
- 13) WALK OVER

WALK (SCHRITT)	
EXTENDED WALK	
JOG/TROT (TRAB)	
EXTENDED TROT	
LOPE (GALOPP)	
EXTENDED LOPE	
BACK UP (RÜCKWÄRTS)	
LEAD CHANGE (GALOPPWECHSEL)	
TURN (DREHUNG)	
	ERSTE
	WESTENREITER
	UNION
	WESTENREITER

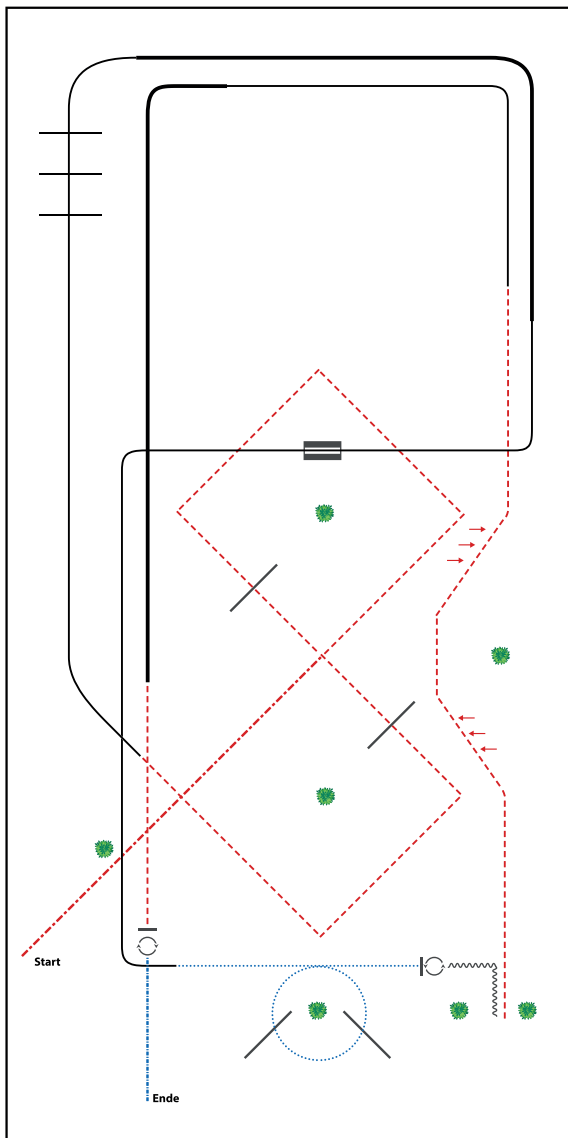

- 1) EXTENDED TROT
- 2) TROT CORNERS, TROT OVER
- 3) LOPE (RL), LOPE OVER
- 4) EXTENDED LOPE (RL), LOPE (RL)
- 5) CHANGE LEADS (SIMPLE OR FLYING)
- 6) LOPE (LL)
- 7) WALK, WALK OVER
- 8) STOP, 1½ TURN LEFT
- 9) BACK UP
- 10) TROT, TWO TACK LEFT AND RIGHT
- 11) LOPE (LL), EXTENDED LOPE (LL)
- 12) TROT, STOP
- 13) 2 TURNS RIGHT
- 14) EXTENDED WALK OUT

WALK (SCHRITT)	.....
EXTENDED WALK	.....
JOG/TROT (TRAB)	.....
EXTENDED TROT	.....
LOPE (GALOPP)	.....
EXTENDED LOPE	.....
BACK UP (RÜCKWÄRTS)	.....
LEAD CHANGE (GALOPPWECHSEL)	.....
TURN (DREHUNG)	.....
ERSTE WESTENREITER	.....
UNION	.....
WESTENREITER	.....

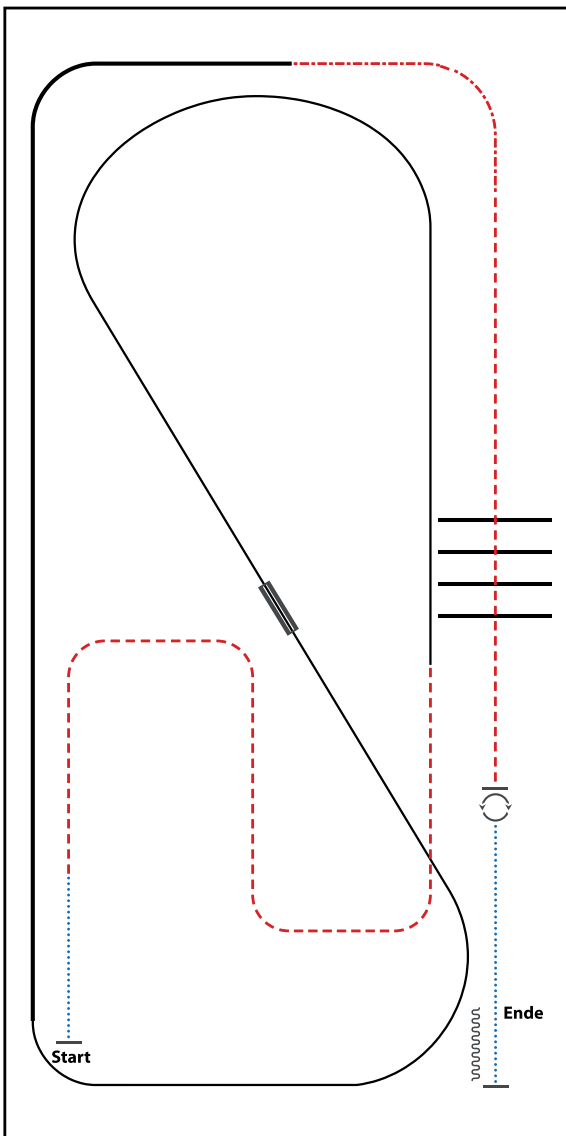

- 1) WALK
- 2) TROT
- 3) LOPE (LL)
- 4) CHANGE LEADS (SIMPLE OR FLYING)
- 5) LOPE (RL)
- 6) EXTENDED LOPE (RL)
- 7) EXTENDED TROT
- 8) TROT
- 9) TROT OVER
- 10) STOP, TURNS 360° (EACH DIRECTION)
- 11) WALK, STOP, BACK UP

WALK (SCHRITT)	
EXTENDED WALK	
JOG/TROT (TRAB)	
EXTENDED TROT	
LOPE (GALOPP)	
EXTENDED LOPE	
BACK UP (RÜCKWÄRTS)	
LEAD CHANGE (GALOPPWECHSEL)	
TURN (DREHUNG)	
	ERSTE
	WESTENREITER
	UNION
	WESTENREITER

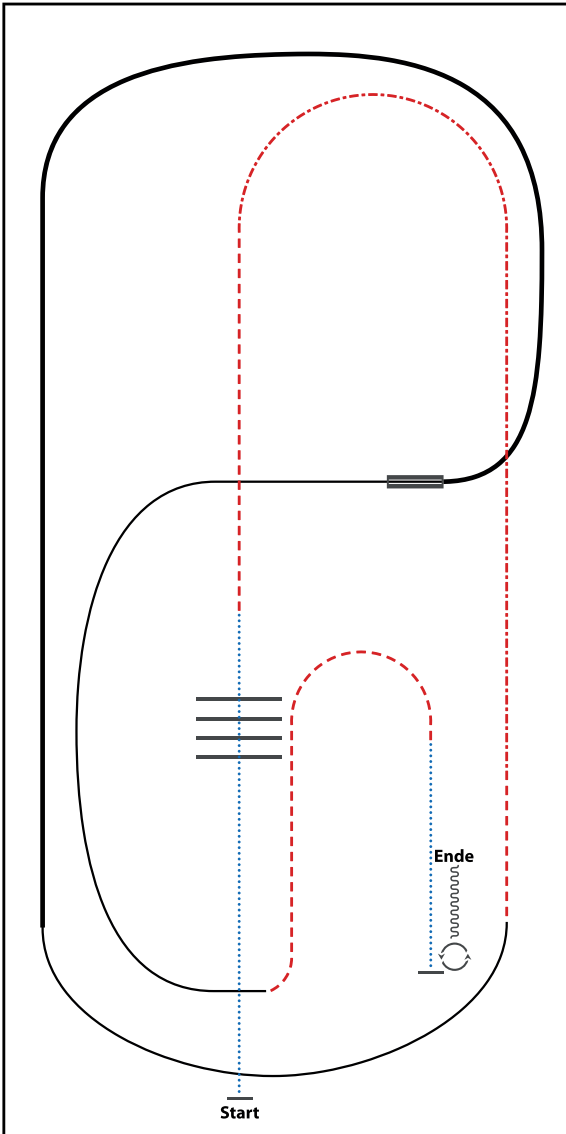

- 1) WALK OVER
- 2) TROT
- 3) EXTENDED TROT, TROT
- 4) LOPE (RL)
- 5) EXTENDED LOPE (RL)
- 6) CHANGE LEADS (SIMPLE OR FLYING)
- 7) LOPE (LL)
- 8) TROT
- 9) WALK
- 10) STOP, TURNS 360° (EACH DIRECTION)
- 11) BACK UP

WALK (SCHRITT)	
EXTENDED WALK	
JOG/TROT (TRAB)	
EXTENDED TROT	
LOPE (GALOPP)	
EXTENDED LOPE	
BACK UP (RÜCKWÄRTS)	
LEAD CHANGE (GALOPPWECHSEL)	
TURN (DREHUNG)	
	ERSTE
	WESTENREITER
	UNION
	WELDMANNREITER

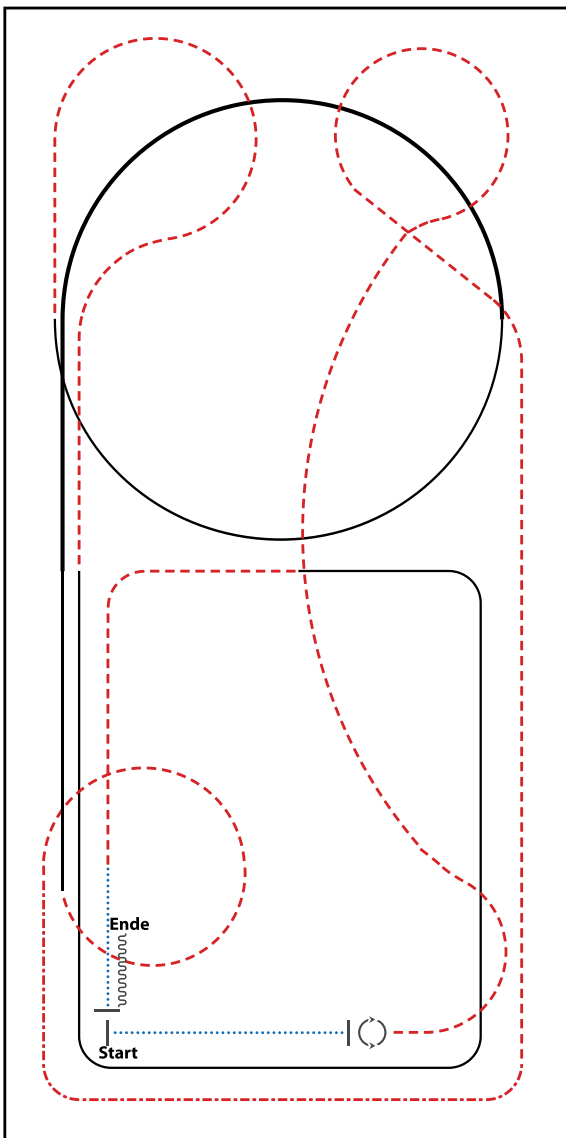

- 1) WALK
- 2) STOP, TURNS 360° (EACH DIRECTION)
- 3) TROT
- 4) EXTENDED TROT, TROT
- 5) LOPE (RL), EXTENDED LOPE (RL), LOPE (RL)
- 6) TROT
- 7) LOPE (LL)
- 8) TROT, WALK
- 9) STOP, BACK UP

WALK (SCHRITT)	
EXTENDED WALK	
JOG/TROT (TRAB)	
EXTENDED TROT	
LOPE (GALOPP)	
EXTENDED LOPE	
BACK UP (RÜCKWÄRTS)	
LEAD CHANGE (GALOPPWECHSEL)	
TURN (DREHUNG)	
	ERSTE
	WESTENREITER
	UNION
	WORLDSPORTREITER



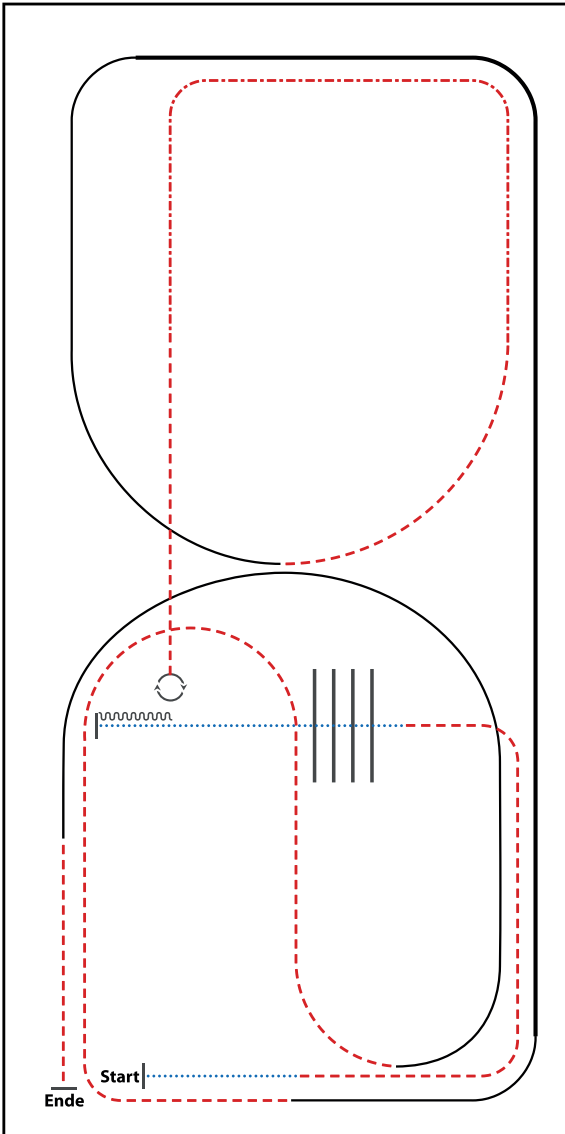

- 1) WALK
- 2) TROT
- 3) WALK OVER, WALK
- 4) STOP, BACK UP, 90° TURN RIGHT
- 5) TROT, EXTENDED TROT, TROT
- 6) LOPE (RL)
- 7) EXTENDED LOPE (RL), LOPE (RL)
- 8) TROT
- 9) LOPE (LL)
- 10) TROT, STOP

WALK (SCHRITT)	
EXTENDED WALK	
JOG/TROT (TRAB)	
EXTENDED TROT	
LOPE (GALOPP)	
EXTENDED LOPE	
BACK UP (RÜCKWÄRTS)	
LEAD CHANGE (GALOPPWECHSEL)	
TURN (DREHUNG)	
ERSTE	
WESTENREITER	
UNION	
WESTENREITER UND UNION	

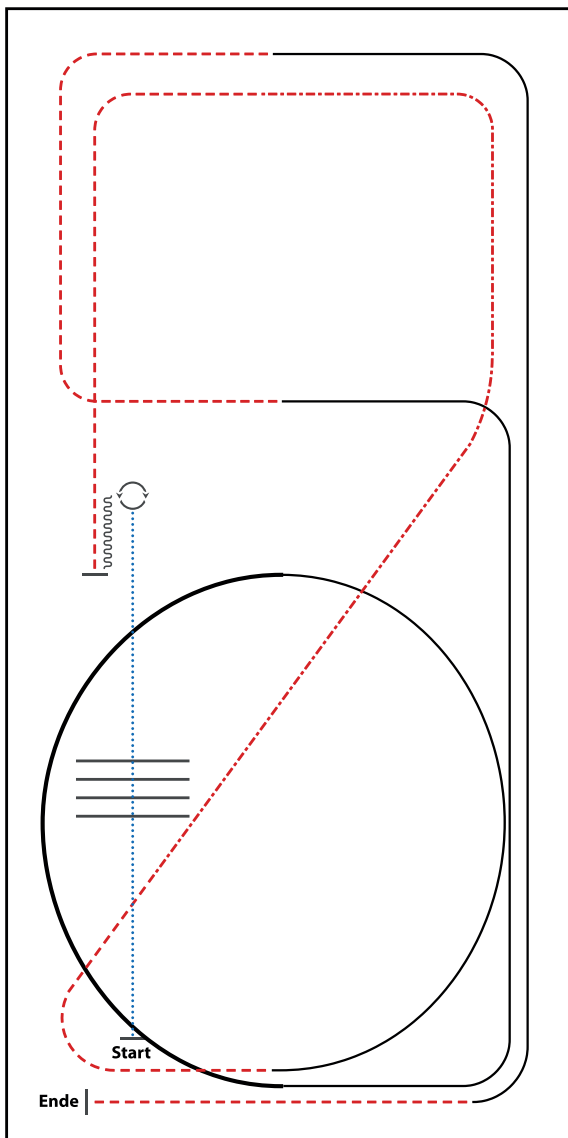

- 1) WALK
- 2) WALK OVER, WALK
- 3) STOP, TURN 360° (LEFT OR RIGHT)
- 4) BACK UP
- 5) TROT
- 6) EXTENDED TROT, TROT
- 7) LOPE (LL)
- 8) EXTENDED LOPE (LL), LOPE (LL)
- 9) TROT
- 10) LOPE (RL)
- 11) TROT, STOP

WALK (SCHRI TT)	
EXTENDED WALK	
JOG/TROT (TRAB)	
EXTENDED TROT	
LOPE (GALOPP)	
EXTENDED LOPE	
BACK UP (RÜCKWÄRTS)	
LEAD CHANGE (GALOPPWECHSEL)	
TURN (DREHUNG)	
ERSTE	
WESTREITER	
UNION	
WESTREITER/UNION	

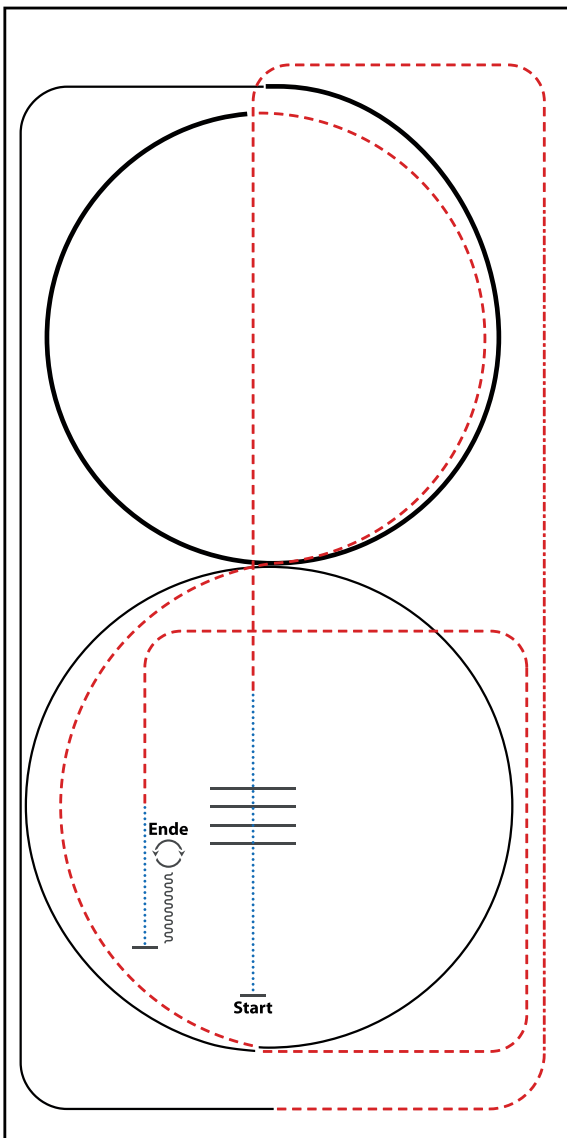

- 1) WALK, WALK OVER
- 2) TROT
- 3) EXTENDED TROT, TROT
- 4) LOPE (RL)
- 5) EXTENDED LOPE (RL)
- 6) TROT (2x ½ CIRCLE)
- 7) LOPE (LL)
- 8) TROT
- 9) WALK
- 10) STOP, BACK UP
- 11) TURN 180° RIGHT
- 12) TURN 180° LEFT

WALK (SCHRITT)	
EXTENDED WALK	
JOG/TROT (TRAB)	
EXTENDED TROT	
LOPE (GALOPP)	
EXTENDED LOPE	
BACK UP (RÜCKWÄRTS)	
LEAD CHANGE (GALOPPWECHSEL)	
TURN (DREHUNG)	
	ERSTE
	WESTENREITER
	UNION
	WELDFÖRDERNDEN VERBÄNDELTEN

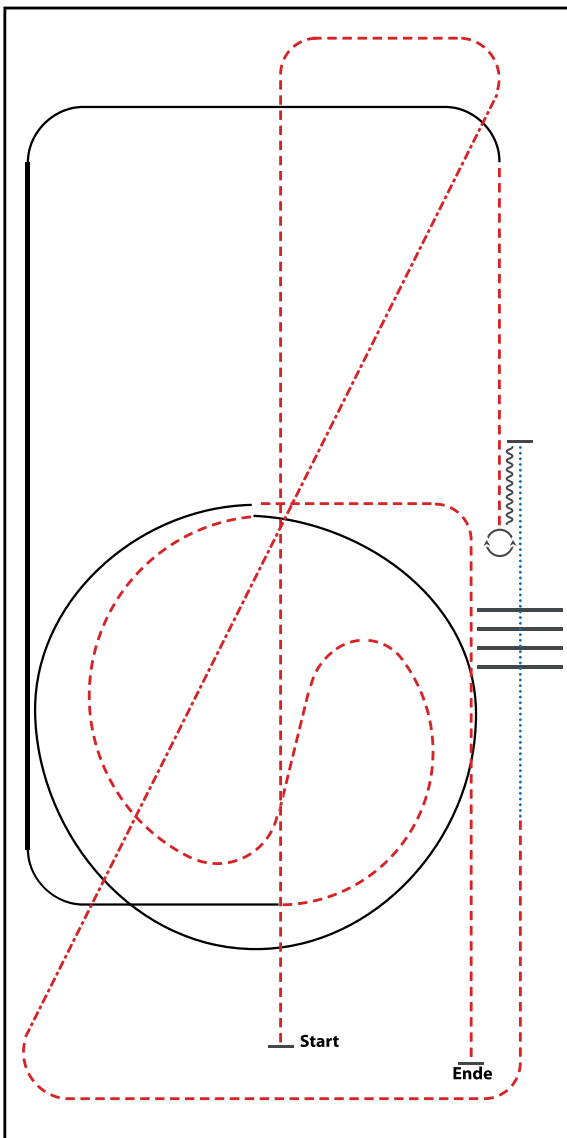

- 1) TROT
- 2) EXTENDED TROT, TROT
- 3) WALK OVER
- 4) WALK
- 5) STOP, BACK UP
- 6) TURN 180° RIGHT
- 7) TURN 180° LEFT
- 8) TROT
- 9) LOPE (LL)
- 10) EXTENDED LOPE (LL), LOPE (LL)
- 11) TROT
- 12) LOPE (RL)
- 13) TROT, STOP

WALK (SCHRITT)	
EXTENDED WALK	
JOG/TROT (TRAB)	
EXTENDED TROT	
LOPE (GALOPP)	
EXTENDED LOPE	
BACK UP (RÜCKWÄRTS)	
LEAD CHANGE (GALOPPWECHSEL)	
TURN (DREHUNG)	
	ERSTE
	WESTENREITER
	UNION
	WESTENREITER
	WESTENREITER

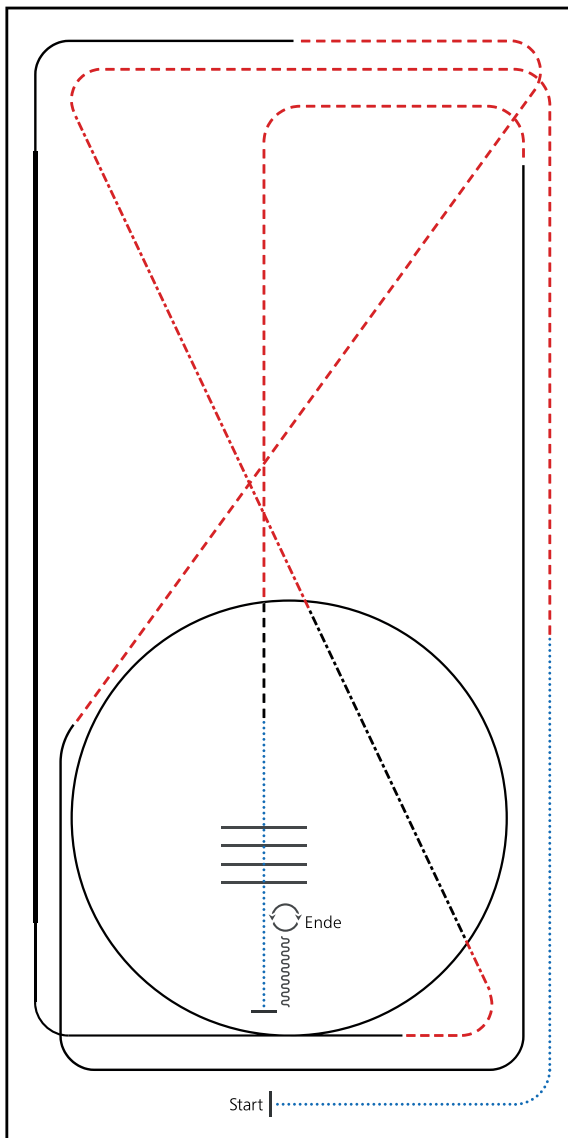

- 1) WALK
- 2) TROT
- 3) EXTENDED TROT, TROT
- 4) LOPE (RL)
- 5) EXTENDED LOPE (RL), LOPE (RL)
- 6) TROT
- 7) LOPE (LL)
- 8) TROT
- 9) WALK, WALK OVER
- 10) STOP, BACK UP
- 11) TURN 180° LEFT
- 12) TURN 180° RIGHT

WALK (SCHRITT)	
EXTENDED WALK	
JOG/TROT (TRAB)	
EXTENDED TROT	
LOPE (GALOPP)	
EXTENDED LOPE	
BACK UP (RÜCKWÄRTS)	
LEAD CHANGE (GALOPPWECHSEL)	
TURN (DREHUNG)	
	ERSTE
	WESTENREITER
	UNION
	WELDPFERDEBUND

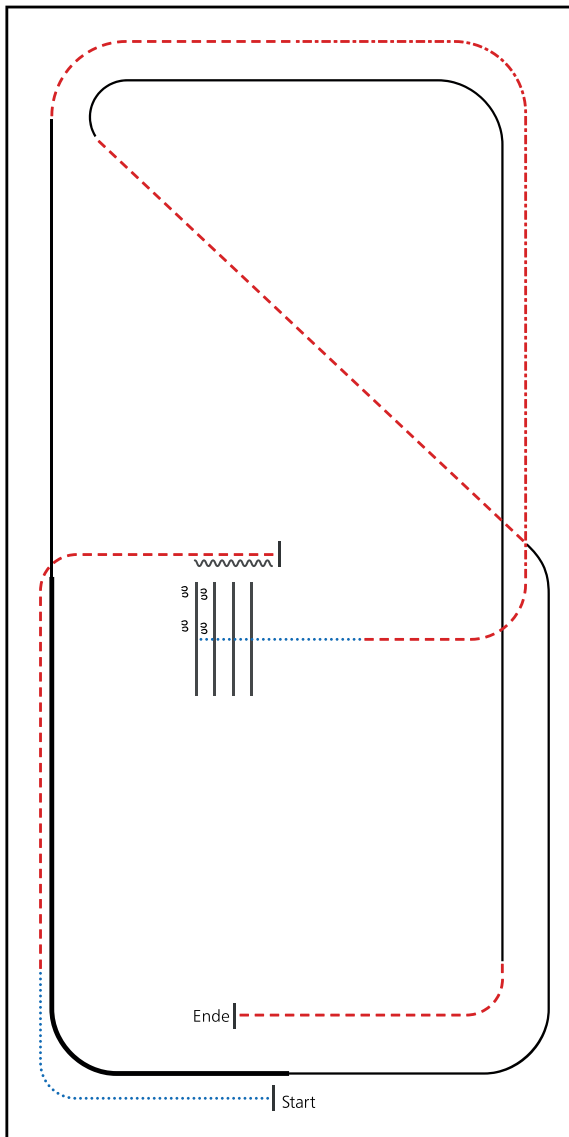

- 1) WALK
- 2) TROT
- 3) STOP, BACK UP
- 4) SIDEPASS RIGHT HALF WAY
- 5) WALK OVER
- 6) TROT
- 7) EXTENDED TROT, TROT
- 8) LOPE (LL)
- 9) EXTENDED LOPE (LL)
- 10) LOPE (LL)
- 11) TROT
- 12) LOPE (RL)
- 13) TROT, STOP

WALK (SCHRITT)

EXTENDED WALK

JOG/TROT (TRAB)

EXTENDED TROT

LOPE (GALOPP)

EXTENDED LOPE

BACK UP (RÜCKWÄRTS)

LEAD CHANGE (GALOPPWECHSEL)

TURN (DREHUNG)

ERSTE

WESTENREITER

UNION

WELDFÖRDERNDES VERBANDSVEREIN

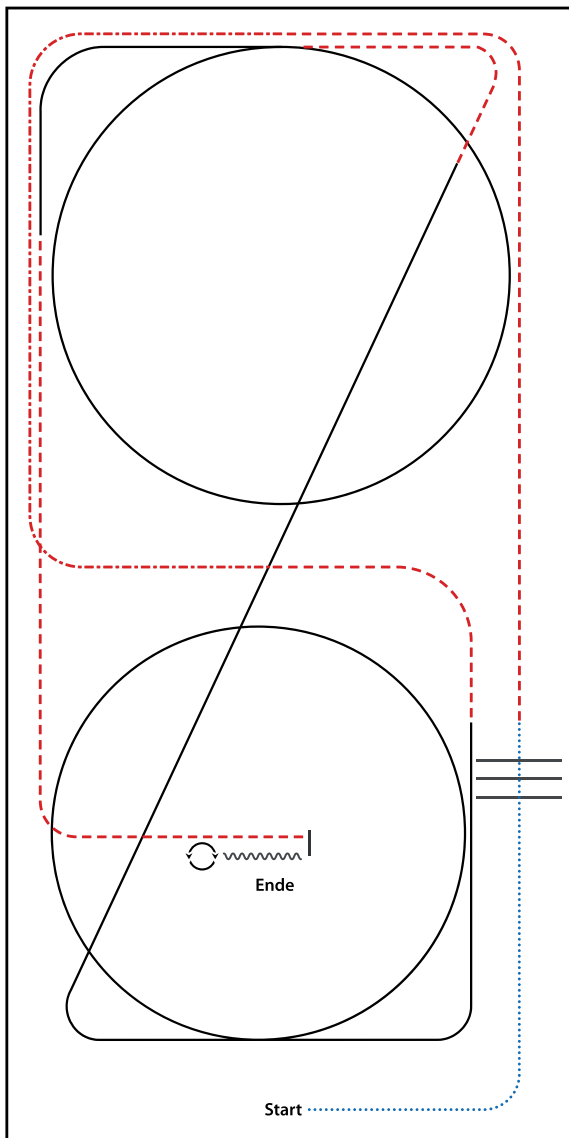

- 1) WALK,
- 2) WALK OVER, WALK
- 3) TROT
- 4) EXTENDED TROT CORNERS, TROT
- 5) LOPE (RL) CIRCLE, LOPE
- 6) TROT
- 7) LOPE (LL) CIRCLE
- 8) TROT
- 9) STOP, BACK UP
- 10) TURN 360° LEFT OR RIGHT

WALK (SCHRITT)	
EXTENDED WALK	
JOG/TROT (TRAB)	
EXTENDED TROT	
LOPE (GALOPP)	
EXTENDED LOPE	
BACK UP (RÜCKWÄRTS)	
LEAD CHANGE (GALOPPWECHSEL)	
TURN (DREHUNG)	





